

**MATERIAL AND EQUIPMENT STANDARD**

**FOR**

**POSITIVE DISPLACEMENT, OIL SEALED-ROTARY**

**VACUUM PUMPS**

**ORIGINAL EDITION**

**JULY 1995**

This standard specification is reviewed and updated by the relevant technical committee on Sep. 2002(1) and Aug. 2014(2). The approved modifications are included in the present issue of IPS.

**FOREWORD**

The Iranian Petroleum Standards (IPS) reflect the views of the Iranian Ministry of Petroleum and are intended for use in the oil and gas production facilities, oil refineries, chemical and petrochemical plants, gas handling and processing installations and other such facilities.

IPS is based on internationally acceptable standards and includes selections from the items stipulated in the referenced standards. They are also supplemented by additional requirements and/or modifications based on the experience acquired by the Iranian Petroleum Industry and the local market availability. The options which are not specified in the text of the standards are itemized in data sheet/s, so that, the user can select his appropriate preferences therein

The IPS standards are therefore expected to be sufficiently flexible so that the users can adapt these standards to their requirements. However, they may not cover every requirement of each project. For such cases, an addendum to IPS Standard shall be prepared by the user which elaborates the particular requirements of the user. This addendum together with the relevant IPS shall form the job specification for the specific project or work.

The IPS is reviewed and up-dated approximately every five years. Each standards are subject to amendment or withdrawal, if required, thus the latest edition of IPS shall be applicable

The users of IPS are therefore requested to send their views and comments, including any addendum prepared for particular cases to the following address. These comments and recommendations will be reviewed by the relevant technical committee and in case of approval will be incorporated in the next revision of the standard.

Standards and Research department

No.17, Street14, North kheradmand

Karimkhan Avenue, Tehran, Iran.

Postal Code- 1585886851

Tel: 021-88810459-60 & 021-66153055

Fax: 021-88810462

Email: [Standards@nioc.ir](mailto:Standards@nioc.ir)

**GENERAL DEFINITIONS:**

Throughout this Standard the following definitions shall apply.

**COMPANY:**

Refers to one of the related and/or affiliated companies of the Iranian Ministry of Petroleum such as National Iranian Oil Company, National Iranian Gas Company, National Petrochemical Company and National Iranian Oil Refinery And Distribution Company.

**PURCHASER:**

Means the "Company" where this standard is a part of direct purchaser order by the "Company", and the "Contractor" where this Standard is a part of contract documents.

**VENDOR AND SUPPLIER:**

Refers to firm or person who will supply and/or fabricate the equipment or material.

**CONTRACTOR:**

Refers to the persons, firm or company whose tender has been accepted by the company.

**EXECUTOR:**

Executor is the party which carries out all or part of construction and/or commissioning for the project.

**INSPECTOR:**

The Inspector referred to in this Standard is a person/persons or a body appointed in writing by the company for the inspection of fabrication and installation work.

**SHALL:**

Is used where a provision is mandatory.

**SHOULD:**

Is used where a provision is advisory only.

**WILL:**

Is normally used in connection with the action by the "Company" rather than by a contractor, supplier or vendor.

**MAY:**

Is used where a provision is completely discretionary.

---

CONTENTS:	PAGE No.
1. SCOPE .....	1
2. REFERENCES .....	1
3. CONFLICTING REQUIREMENTS .....	2
4. UNITS .....	2
5. SIZE, CLASS AND TYPE OF PUMPS .....	2
6. TERMS AND DEFINITIONS .....	4
7. DESIGN AND CONSTRUCTION .....	7
7.1 General .....	7
7.2 Pump Body .....	8
7.3 Pump Connections .....	8
7.4 Rotating Elements .....	9
7.5 Main Shaft .....	9
7.6 Bearings and Bearing Housings .....	9
7.7 Seals .....	10
7.8 Lubrication .....	10
7.9 Discharge Valves .....	10
7.10 Material .....	10
7.11 Marking .....	11
8. ACCESSORIES .....	11
8.1 Drivers .....	11
8.2 Power Transmission Parts .....	11
8.3 Common Bed .....	12
9. INSPECTION AND TESTING .....	12
9.1 General .....	12
9.2 Inspection .....	12
9.3 Tests .....	13
9.4 Performance .....	14
10. PREPARATION FOR SHIPMENT .....	14
11. GUARANTEE AND WARRANTY .....	15
11.1 Mechanical .....	15
11.2 Performance .....	15
12. VENDOR DATA REQUIREMENTS .....	15
APPENDICES:	
APPENDIX A TYPICAL DRAWINGS OF ROTARY VACUUM PUMPS .....	16

## 1. SCOPE

**1.1** This Standard covers the minimum requirements for "Positive-displacement Oil-Sealed Rotary Vacuum Pumps" having continuous rating of ultimate pressure not exceeding 100 Pa and nominal discharge rate of 1.2 to 900 m<sup>3</sup>/h driven by an Induction motor for use in refinery services, chemical and petrochemical plants and where applicable in other services.

### Notes:

1) 100 Pa = 100 N/m<sup>2</sup> = 1 m bar  $\cong$  0.75 torr

2) Typical drawings of different types of rotary vacuum pumps are shown in Appendix A.

**1.2** Compliance by the pump manufacturer with the provisions of this Standard does not relieve him of the responsibility of furnishing pump and accessories of proper design, mechanically suited to meet guarantees at the specified service conditions.

**1.3** No deviations or exceptions from this Standard shall be permitted without written approval of the purchaser.

Intended deviations from this standard shall be separately listed by the vendor and supported by reasons thereof for purchaser consideration.

### Note 1:

**This standard specification is reviewed and updated by the relevant technical committee on Sep. 2002. The approved modifications by T.C. were sent to IPS users as amendment No. 1 by circular No. 197 on Sep. 2002. These modifications are included in the present issue of IPS.**

### Note 2:

**This standard specification is reviewed and updated by the relevant technical committee on Aug. 2014. The approved modifications by T.C. were sent to IPS users as amendment No. 2 by circular No. 428 on Aug. 2014. These modifications are included in the present issue of IPS.**

## 2. REFERENCES

Throughout this Standard the following dated and undated standards/codes are referred to. These referenced documents shall, to the extent specified herein, form a part of this standard. For dated references, the edition cited applies. The applicability of changes in dated references that occur after the cited date shall be mutually agreed upon by the Company and the Vendor. For undated references, the latest edition of the referenced documents (including any supplements and amendments) applies.

### **AFBMA (ANTI FRICTION BEARING MANUFACTURER ASSOCIATION)**

### **ANSI (AMERICAN NATIONAL STANDARDS INSTITUTE)**

- |         |  |
|---------|--|
| B.16.5  | "Pipe Flanges and Flanged Fittings, Steel Nickel Alloy and Other Special Alloys" |
| J 636 C | "V-Belts and Pulleys"  |

**ASME (AMERICAN SOCIETY OF MECHANICAL ENGINEERS)**

B 16.1 Boiler and Pressure Vessel Code, Section IX, "Welding and Brazing qualifications"

**ASTM (AMERICAN SOCIETY FOR TESTING AND MATERIALS)**

A-278 "Gray Iron Castings for Pressure-Containing Parts for Temperature Up to 345°C"

A-395 "Ferritic Ductile Iron Pressure Retaining Castings for Use at Elevated Temperatures"

A-536 "Ductile Iron Casting"

**IPS (IRANIAN PETROLEUM STANDARDS)**

[IPS-E-EL-110](#) "Engineering Standard for Hazardous Area"

[IPS-E-PM-400](#) "Engineering Standard for Vendor's Data Requirements"

[IPS-M-EL-132](#) "Material And Equipment Standard for Induction Motors"

[IPS-M-PM-320](#) "Lubrication, Shaft-Sealing, Oil-Control System and Auxiliaries"

**OSHA (OCCUPATIONAL SAFETY AND HEALTH ADMINISTRATION)****SAE (SOCIETY OF AUTOMATIVE ENGINEERING)****3. CONFLICTING REQUIREMENTS**

In the case of conflict between documents relating to the inquiry or order, the following priority of documents shall apply:

First Priority : Purchase Order and variations thereto.

Second Priority : This Standard Specification.

All conflicting requirements shall be referred to the purchaser in writing. The Purchaser will issue confirmation document if needed for clarification.

**4. UNITS**

This standard is based on International System of Units (SI), as per [IPS-E-GN-100](#) except otherwise specified.

**5. SIZE, CLASS AND TYPE OF PUMPS**

**5.1** The size of pumps shall be represented by the nominal discharge rate based on the design discharge rate. The range of design discharge rates and the corresponding rated motor outputs are shown in Table 1.

**5.2** The class of pumps shall be represented by the ultimate pressure and are classified as shown in Table 2.

**5.3** Pumps shall be classified as shown in Table 3 according to their type and cooling system. (see Appendix A for pumps drawing and related parts.)

5.4 The nominal symbols of pumps shall be indicated as follows:

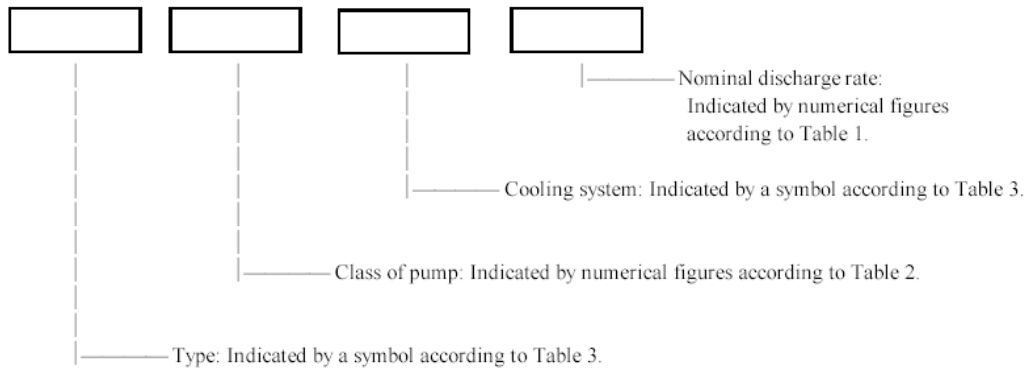

**Examples:**

R3A18	Sliding vane type class 3 air-cooled pump
C3A9	Rotary piston type Class 3 air-cooled pump
P2W150	Rotary plunger type Class 2 water-cooled pump

**TABLE 1 - SIZE OF PUMPS**

NOMINAL DISCHARGE RATE m <sup>3</sup> /h	DESIGN DISCHARGE RATE m <sup>3</sup> /h	RATED MOTOR OUTPUT kW
1.2	1.2 to 1.32	0.1
3	3 to 3.3	0.2
9	9 to 9.9	0.4
18	18 to 19.8	0.75
30	30 to 33	0.75
48	48 to 52.8	1.5
90	90 to 99	2.2
150	150 to 165	3.7
220	220 to 242	5.5
330	330 to 363	7.5
450	450 to 495	11
600	600 to 660	15
900	900 to 990	22

**TABLE 2 - CLASS OF PUMPS**

CLASS OF PUMP	ULTIMATE PRESSURE Pa
CLASS 1	100 AND UNDER
CLASS 2	UNDER 1
CLASS 3	UNDER 0.1

**TABLE 3 - TYPE OF PUMPS**

TYPE AND COOLING SYSTEM		SYMBOL
TYPE	SLIDING VANE TYPE	R
	ROTARY PISTON TYPE	C
	ROTARY PLUNGER TYPE	P
COOLING SYSTEM	AIR COOLING	A
	WATER COOLING	W

## 6. TERMS AND DEFINITIONS

### 6.1 Vacuum Pump

Vacuum pump is a device for creating, improving and/or maintaining a vacuum. Two basically distinct categories may be considered: Gas transfer pumps and entrapment or capture pumps.

### 6.2 Positive Displacement (Vacuum) Pump

A Positive Displacement vacuum pump is a pump in which a volume filled with gas is cyclically isolated from the inlet, the gas being then transferred to an outlet. In most types of the positive displacement pumps the gas is compressed before the discharge at the outlet. Two categories can be considered: Reciprocating positive displacement pumps and rotary positive displacement pumps.

### 6.3 Gas Ballast (Vacuum) Pump

Gas ballast vacuum pump is a positive displacement pump in which a controlled quantity of a



suitable non-condensable gas is admitted during the compression part of the cycle so as to reduce the extent of condensation within the pump.

#### **6.4 Oil-Sealed [Liquid-Sealed] Vacuum Pump**

Oil-Sealed vacuum pump is a rotary positive displacement pump in which oil is used to seal the gap between parts which move with respect to one another and to reduce the residual free volume in the pump chamber at the end of the compression part of the cycle.

#### **6.5 Dry-Sealed Vacuum Pump**

Dry-Sealed vacuum pump is a positive displacement pump which is not oil-sealed (liquid-sealed).

#### **6.6 Sliding Vane Rotary Vacuum Pump**

Sliding vane rotary vacuum pump is a rotary positive displacement pump in which an eccentrically placed rotor is turning tangentially to the fixed surface of the stator. Two or more vanes sliding in slots of the rotor (usually radial) and rubbing on the internal wall of the stator, divide the stator chamber into several parts of varying volume.

#### **6.7 Rotary Piston Vacuum Pump**

Rotary piston vacuum pump is a rotary displacement pump in which a rotor is turning eccentrically, in contact with the internal wall of the stator. A device moving relative to the stator is pressed against the rotor and divides the stator chamber into parts of varying volume.

#### **6.8 Rotary Plunger Vacuum Pump**

Rotary plunger vacuum pump is a rotary displacement pump in which a rotor is turning eccentrically to the internal wall of the stator. The stator chamber is divided into two parts of varying volume by a vane rigidly fixed to the rotor. The vane slides in a plug oscillating in an appropriate housing in the stator.

#### **6.9 Pump Case**

Pump case is the external wall of a pump, which separates the low pressure gas from the atmosphere.

#### **6.10 Inlet**

Inlet is the port by which gas to be pumped enters a pump.

#### **6.11 Outlet**

Outlet is the outlet or discharge port of a pump.

#### **6.12 Vane; Blade**

Vane or blade is a sliding member which divides into compartments the working space between the rotor and stator in some positive displacement rotary pumps.

#### **6.13 Discharge Valve**

Discharge valve is a valve operating automatically for the discharge of gas from the compression chamber of some positive displacement pumps.

#### 6.14 Expansion Chamber

Expansion chamber is the increasing space within the stator chamber of some positive displacement pumps, into which the pumped gas is expanded.

#### 6.15 Compression Chamber

Compression chamber is the decreasing space within the stator chamber of some positive displacement pumps, into which the gas is compressed before being discharged.

#### 6.16 Vacuum Pump Oil

Vacuum pump oil is the liquid used for sealing, cooling and lubrication, in oil-sealed vacuum pumps.

**Note:**

**The term pump oil is also commonly used to describe pump fluids used in oil vapor pumps. this note does not apply to the German expression.**

#### 6.17 Volume Flow Rate of a Vacuum Pump

[Symbol: S; Unit:  $\text{m}^3 \cdot \text{s}^{-1}$ ]: Volume flow rate of a vacuum pump is the volume flow rate of the gas removed by the pump from the gas phase within the evacuated chamber. This kind of definition is only applicable to pumps which are distinct devices, separated from the vacuum chamber.

For practical purposes, however, the volume flow rate of a given pump for a given gas is, by convention, taken to be the throughput of that gas flowing from a standardized test dome connected to the pump, divided by the equilibrium pressure measured at a specified position in the test dome, and under specified conditions of operation.

#### 6.18 Throughput of a Vacuum Pump

[Symbol: Q; Unit:  $\text{Pa} \cdot \text{m}^3 \cdot \text{s}^{-1}$ ]: Throughput of a vacuum pump is the throughput flowing through the inlet of the pump.

#### 6.19 Starting Pressure

Starting pressure is the pressure at which a pump can be started without damage and a pumping effect can be obtained.

#### 6.20 Backing Pressure

Backing pressure is the pressure at the outlet of a pump which discharges gas to a pressure below atmospheric.

#### 6.21 Critical Backing Pressure

Critical backing pressure is the backing pressure above which a vapor jet or diffusion pump fails to operate correctly. It is the highest value of the backing pressure at which a small increment in the backing pressure does not yet produce a significant increase of the inlet pressure. The critical backing pressure of a given pump depends mainly on the throughput.

**Note:**

**For some pumps the failure does not occur abruptly and the critical backing pressure cannot then be precisely stated.**

**6.22 Maximum Backing Pressure**

Maximum backing pressure is the backing pressure above which a pump can be damaged.

**6.23 Maximum Working Pressure**

Maximum working pressure is the inlet pressure corresponding to the maximum gas flow rate that the pump is able to withstand under continuous operation without any deterioration or damage.

**6.24 Ultimate Pressure of a Pump**

Ultimate pressure of a pump is the value towards which the pressure in a standardized test dome tends asymptotically, without introduction of gas and with the pump operating normally. A distinction may be made between the ultimate pressure due only to non-condensable gases and the total ultimate pressure due to gases and vapors.

**6.25 Compression Ratio**

Compression ratio is the ratio of the outlet pressure to the inlet pressure, for a given gas.

**6.26 Back-Diffusion of Gas**

Back-diffusion of gas is the passage of gas, opposite to the pumping action, from the outlet to the inlet port of a vacuum pump (or of any associated baffle or trap).

**6.27 Oil Separator**

Oil separator is a device which reduces the loss of pump oil by entrainment as droplets at the outlet of a vacuum pump.

**6.28 Oil Purifier**

Oil purifier is a device for removing contaminants from the pump oil.

**6.29 Trap**

Trap is a device in which the partial pressure of the constituents of a mixture of gases and vapors is reduced by physical or chemical means.

**6.30 Cold Trap**

Cold trap is a trap which operates by condensation on cooled surfaces.

**7. DESIGN AND CONSTRUCTION****7.1 General**

**7.1.1** The pump rating shall be well within the range of the manufacturer's actual experience. Only equipment which has proven its reliability in service for minimum of two years, is acceptable.

**7.1.2** Unless otherwise specified, the following limits shall be met at any measuring location at 1 m from the equipment surface:

EQUIPMENT	Sound Pressure Limit in dB Reference Equivalent (RE) 20 µPa
PUMP PUMP + DRIVER	87 dB (A) 90 dB (A)

If the equipment produces impulsive and/or narrow band noise, the above limits shall be taken 5 dB(A) lower, thus 82 dB(A) for pump and 85 dB(A) for the pump +driver.

**7.1.3** The arrangement of the equipment, including piping and auxiliaries, shall provide adequate clearance areas and safe access for operation and maintenance.

**7.1.4** All electrical components and installations shall be suitable for the area classification and grouping specified by the Purchaser, complying the requirements of [IPS-E-EL-110](#).

**7.1.5** All equipment, particularly packing and seals, shall be designed to permit rapid and economical maintenance. Major parts shall be designed (shouldered or doweled) and manufactured to ensure accurate alignment on reassembly.

**7.1.6** The Purchaser shall specify whether the installation is indoors (heated or unheated) or outdoors (with or without a roof) and the weather/environmental conditions in which the equipment must operate (including maximum and minimum temperatures, unusual humidity, or dust problems). The unit and its auxiliaries shall be suitable for operation in these specified conditions.

For the purchaser's guidance, the vendor shall list in the proposal any special protection required by the purchaser.

**7.1.7** The pump shall have sufficient strength in those parts applied with outside pressure, and be capable of being operated properly without mechanical or electrical failure in the respective parts and without remarkable vibration during use.

**7.1.8** The vendor shall assume unit responsibility for all equipment including pump, driver, power transmission, and all auxiliary systems in the scope of the order.

**7.1.9** Spare parts for the machine and all furnished auxiliaries shall meet all the criteria of this standard.

**7.2 Pump Body**

**7.2.1** The pump body shall consist of a case, cylinder, and cover, or a cylinder and cover.

**7.2.2** The cylinder and cover shall be airtight and abrasion-resistant, and their connecting parts and sliding parts shall be finished by fine machining.

**7.2.3** The as-cast parts within the case, cylinder, and cover shall be free from casting sand and scales, as well as flow holes, flaws, or the like. The connecting parts between the cover and the case or cylinder shall be airtight and free from oil leakage to the outside.

**7.2.4** The cover and the case or cylinder shall be connected so as to allow easy centering between them.

**7.2.5** The outer parts of the case or cylinder shall have a heat radiator construction or be provided with a water cooling jacket, as required.

**7.2.6** The details of threading shall conform to ASME B.1.1.

**7.3 Pump Connections**

**7.3.1** Inlet and outlet connections shall be provided with a flange, a coupling, or a clamp or rubber tube coupling, as specified.

**7.3.2** Cast iron flanges shall be flat faced and shall have a minimum thickness of class 250 per ASME B16.1.

**7.3.3** External threaded connections shall not exceed DN 40 (1½ inch). Tapped openings and bosses for pipe threads shall conform to ASME Standard B 16.5. Threads shall be lubricated. Tape shall not be applied to the threads of plugs in oil passages. Plastic plugs shall not be used.

**7.3.4** The cooling water inlet and outlet connections shall be minimum DN 15 (½ inch).

**7.3.5** Openings for NPS 1-1/4, 2-1/2, 3-1/2, 5, 7 and 9 shall not be used.

**7.3.6** All of the purchaser's connections shall be accessible for disassembly without the machine being moved.

## **7.4 Rotating Elements**

**7.4.1** Rotors and shafts shall be stiff enough to prevent contact between the rotor bodies and the casing.

Rotor bodies not integral with the shaft shall be permanently fixed to the shaft to prevent relative motion under any condition.

**7.4.2** The rotor, vane, blade, piston, and slide pin of the pump shall meet the following requirements:

- a) The respective parts shall be abrasion-resistant and finely finished, and be free from remarkable unevenness in wall thickness, blowholes, flaws, and the like.
- b) The sliding areas of the respective parts shall be constructed so as to be sufficiently maintained airtight and lubricated by means of an oil film during operation.

## **7.5 Main Shaft**

**7.5.1** Shafts shall be provided with seal or packing sleeves of wear, corrosion, and erosion resistant material.

## **7.6 Bearings and Bearing Housings**

**7.6.1** The bearings shall be ball or roller bearings and shall have a minimum L-10 rated life or either 25000 hours with continuous operation at rated conditions, or 16000 hours at maximum axial and radial loads and rated speed.

**7.6.2** The bearings shall be free from flowing out or splashing of oil and grease, and if required, the lubricating oil shall be supplied from an oil cup by a system separate from the oiling system for the cylinder.

**7.6.3** Bearings shall be retain on the shaft and fitted into housing in accordance with methods and procedures contained in Anti-Friction Bearing Manufacturers Association (AFBMA) publications.

**7.6.4** Bearing bushes, shall be fitted rigidly to the bearing housing and provided with a revolving stopper, and their length shall be not smaller than 1.2 times the shaft diameter.

**7.6.5** Housings for separately lubricated bearings shall be sealed against external contaminants; such housings for oil lubricated bearings shall contain a drain at the low point and shall be equipped with an oil-level gage.

**7.6.6** When grease lubricated bearings are supplied, the manufacturer's design shall include a provision to protect against over greasing.

**7.7 Seals**

**7.7.1** Unless otherwise specified the type of shaft seals shall be selected by the Vendor.

**7.7.2** Unless otherwise specified the mechanical seal/packing type and material shall be selected by the Vendor.

**7.7.3** Selected seals shall have sufficient oil resistance and heat resistance and their sliding parts shall be air tight and free from outward oil leakage.

**7.8 Lubrication**

**7.8.1** The oil tank of the pump shall have sufficient strength and be free from flowing out or splashing of oil during operation, and be provided with an oil gage to allow easy inspection of the oil level.

In addition, the tank body shall be provided with an air discharge opening, oil drain opening, and oil supply opening.

**7.8.2** The recommended lubricating oil shall be of regular type available in the market. Special type lubricating oil is not acceptable.

**7.8.3** The Vendor shall specify the type, amount, and frequency of lubrication for separately lubricated bearings.

**7.8.4** The pump shall not spout oil in a remarkable degree during operation.

**7.8.5** The oil shall not leak from the pump body or oil tank.

**7.8.6** Any points that require grease lubrication shall have suitable extension lines to permit access during operation.

**7.9 Discharge Valves**

The discharge valve of the pump shall operate smoothly and shall not be susceptible to breakage or fastening with rust.

**7.10 Material****7.10.1 General**

**7.10.1.1** Material of construction shall be Manufacturer's Standard for the specified operating conditions unless otherwise specified by the purchaser.

**7.10.1.2** Materials shall be identified in the proposal with the applicable ASTM or AISI numbers including material grade.

**7.10.1.3** External part subject to rotary or sliding motions (such as control linkage joints and adjusting mechanisms) shall be of corrosion-resistant materials suitable for the site environment.

**7.10.2 Castings**

**7.10.2.1** Castings shall be sound and free of shrink holes, blow holes, cracks, scale, blisters, or other similar injurious defects. The surfaces of castings shall be cleaned by sandblasting, Shot-blasting, pickling, or any other standard method. All mold-parting fins and remains of gates and risers shall be chipped, filed, or ground flush.

**7.10.2.2** Weldable grades of steel castings may be repaired by welding, using a qualified welding procedure based on the requirements of Section IX of the ASME Code.

**7.10.2.3** Cast gray iron or nodular iron may be repaired by plugging within the limits specified in ASTM A 278 or A 395, respectively. The drilled holes for a plug shall be carefully examined with dye penetrant to ensure the removal of all defective material. All necessary repairs not covered by ASTM shall be subjected to approval by the purchaser.

**7.10.2.4** Nodular iron castings shall be produced in accordance with the reference specifications ASTM A 395 or A 536. (The grade shall be specified by the Vendor.)

## 7.11 Marking

Pumps shall be attached with a name plate and marked with an arrow mark indicating the direction of rotation (the direction of rotation shall as a rule be clockwise viewed from the driving side) at an easily visible location, and the following items of information shall be marked on the name plate:

- a) Type name by the manufacturer.
- b) Symbol of pump.
- c) Nominal discharge rate ( $m^3/h$ ).
- d) Ultimate pressure (Pa).
- e) Driving motor (with number of poles if required) (kW).
- f) Number of revolutions (rpm).
- g) Oil quantity (*l*).
- h) Manufacturer's name or registered trade mark.
- i) Manufacture number and year of manufacture.

## 8. ACCESSORIES

### 8.1 Drivers

**8.1.1** Pumps shall be provided with motor drivers.

**8.1.2** Motor drivers shall be supplied in accordance with [IPS-M-EL-132](#).

**8.1.3** The motor name plate rating (excluding service factor) shall be a minimum of 110 percent of the greatest horsepower (including all losses) required for any of the specified operating conditions.

**8.1.4** Motor for belt drives shall be of extended-shaft construction and shall be suitable for the side loads imposed by the drive.

**8.1.5** Chain drives are not acceptable unless approved otherwise by the Purchaser.

### 8.2 Power Transmission Parts

**8.2.1** A flexible coupling or a pulley with belt shall be provided between the driver and the driven equipment.

**8.2.2** Pulleys and V-belts shall comply ANSI / SAE Standard J 636c.

**8.2.3** Removable guards shall be supplied for couplings and/or V-belt and pulleys according to OSHA requirements.

**8.3 Common Bed**

The Vendor shall furnish a common bed to accommodate the pump and driver. Beds shall be capable of withstanding the total weight of the pump body and driving motor as well as produced vibrations.

**9. INSPECTION AND TESTING****9.1 General**

**9.1.1** The Vendor shall provide the purchaser with advance notification of certain shop inspections and tests as outlined in the purchase order or other agreement.

**9.1.2** Purchaser's representative shall have the rights to reject the equipment or any part of it which do not conform to the purchase order.

**9.2 Inspection**

**9.2.1** The Vendor shall keep the following data available for examination by the purchaser or his representative upon request:

- 1) Certification of materials, including typical mill test reports.
- 2) Typical purchase specifications for all items on bills of materials.
- 3) Running test data to verify that the requirements of the specification are being met.

**9.2.2** The inspection shall be performed with respect to the following items and the results shall meet the requirement of this Standard:

- a) Performance
- b) Construction, shape, and dimension
- c) Appearance
- d) Material
- e) Marking.



### 9.3 Tests

#### 9.3.1 General

**9.3.1.1** The Vendor shall notify the Purchaser not less than 30 days prior to the date the equipment will be ready for test.

**9.3.1.2** Equipment for specified tests shall be provided by the Vendor.

**9.3.1.3** Acceptance of shop tests does not constitute a waiver of requirements to meet field performance under specified operating conditions, nor does inspection relieve the Vendor of his responsibilities.

**9.3.1.4** The Manufacturer shall maintain a complete log of the tests performed and shall prepare the required number of copies of the test report, certified as to correctness.

**9.3.1.5** The vendor shall operate a quality management system to ensure that the technical requirements of this Standard are achieved. Purchaser may require demonstration of the quality system, but this may be waived if the system has been verified recently by an accreditation scheme acceptable to purchaser.

The vendor shall ensure that QA requirements specified in the enquiry and purchase documents are applied to all materials, equipment and services provided by sub-contractors and to any free issue materials.

**9.3.1.6** Purchaser's representative shall have the right to reject any parts of equipment which do not conform to the purchase Order.

#### 9.3.2 Test conditions

The test conditions for pumps shall, as a rule, be as follows:

- 1) The number of revolutions of the pump shall be made agree with the prescribed number of revolutions.
- 2) The motor used shall be the prescribed one.
- 3) For the pump oil, an oil of the prescribed kind shall be used in the prescribed quantity.
- 4) Where cooling water is used, its temperature, flow rate, and the like shall be made agree with the prescribed conditions.
- 5) The gas used in the measurement shall be air at the atmospheric temperature.
- 6) The conditions of the test atmosphere (temperature, pressure and the like) shall be measured.
- 7) There shall not be present abnormal vibration or noise in the prescribed running condition.

#### 9.3.3 Ultimate pressure test

An ultimate pressure of the pump shall be measured by using a Mcleod vacuum gage.

The ultimate pressure of the pump shall be expressed by the value of the lowest pressure obtainable by the pump in the stationary running condition in which no gas is introduced from the suction inlet, measured by the vacuum gage capable of accurately measuring to one significant figure.

#### 9.3.4 Required electric power test

The required electric power of the pump shall be measured as follows:

- a) Measurement shall be carried out in the stationary or approximately stationary running condition.

- b) The measured value shall be read to 2 significant figures.
- c) Measurement shall be carried out at suitable pressure intervals in a suction pressure range of from atmospheric pressure to about 100 Pa.

### 9.3.5 Temperature rise test

The temperature rise shall be measured as follows:

- Measurement shall be carried out in the stationary or approximately stationary running condition.
- Measurement shall desirably be carried out in a wide range of suction pressure. In addition, the temperature rise in the unloaded condition ( $Q = 0$ ) shall be measured without fail.

The results of measurement shall include the positions of temperature measurement, kind of thermometer, and cooling conditions.

### 9.3.6 Back streaming of oil test

The test for back streaming of oil shall be performed by stopping the operation of the pump and leaving it standing for 10 min. with the inlet maintained vacuum, thus examining the presence or absence of a back streaming.

## 9.4 Performance

Pump performance shall meet the following requirements:

- 1) The ultimate pressure shall satisfy the values shown in Table 2.
- 2) The output of the driving motor when the pump performs the maximum compression work at the prescribed number of revolutions\* shall not exceed the rated output shown in Table 1.
- 3) When the pump is tested there shall not occur a rise in temperature likely to produce harmful effects such as hindering the driving of the pump or disabling operation.
- 4) When the pump is tested the oil shall not back-stream to or beyond the inlet surface.
- 5) The pump shall not produce abnormal vibrations or noises during operation.
- 6) The pump shall not spout oil in a remarkable degree during operation.
- 7) The oil shall not leak from the pump body or oil tank.
- 8) Variable speed pumps shall be tested additionally at other speeds (operating points) specified in data/requisition sheets including maximum continuous speed and minimum allowable speed.

\* The prescribed number of revolutions means the number of revolutions of the pump decided by design.

## 10. PREPARATION FOR SHIPMENT

**10.1** Equipment shall be suitably prepared for the type of shipment specified by the purchaser. The preparation shall be suitable for a period of 18 months of outdoor storage from the time of shipment, such that disassembly is not required, except for bearing and seal inspections, prior to operation.

**10.2** Preparation for shipment shall be made after all testing and inspection of the equipment has been accomplished. Minimum preparation shall include that specified in 10.2.1 through 10.2.5.

**10.2.1** All exterior surfaces with the exception of machined surfaces shall be given a coat of the manufacturer's standard paint.

**10.2.2** All exterior machined surfaces shall be coated with a suitable rust preventive.

**10.2.3** The interior of the equipment shall be sprayed or flushed with a suitable rust preventive that is removable with solvent.

**10.2.4** All flanged openings shall be provided with metal closures of 5 millimeters minimum thickness, with rubber gaskets and at least four full-diameter bolts.

**10.2.5** All threaded openings shall be provided with steel caps or solid-shank steel plugs. In no case shall nonmetallic plugs (such as plastic) be used.

**10.3** Each pump shall be identified with item and serial numbers. Unless otherwise specified separate shipment of materials is not allowed.

## **11. GUARANTEE AND WARRANTY**

### **11.1 Mechanical**

Unless exception is recorded by the Vendor in his proposal, it shall be understood that the Vendor agrees to the guarantees and warranties specified in 11.1.1 and 11.1.2.

**11.1.1** All equipment and component parts shall be warranted by the Vendor against defective materials, design, and workmanship for 1 year after being placed in service (but not more than 18 months after the date of shipment).

**11.1.2** If any malperformance or defects occur during the guarantee and warranty period, the Vendor shall make all necessary alterations, repairs, and replacements free of charge, free on board factory. Field labor charges, if any, shall be subject to negotiation between the Vendor and the Purchaser.

### **11.2 Performance**

The equipment shall be guaranteed for satisfactory performance at all operating conditions specified by the purchaser.

## **12. VENDOR DATA REQUIREMENTS**

Vendor data at proposal stage and after placing the order shall be as specified in [IPS-E-PM-400](#).

**APPENDICES**

**APPENDIX A**

**TYPICAL DRAWINGS OF ROTARY VACUUM PUMPS**

This Appendix gives the typical drawings concerning different types of rotary pumps.

The figures are for explanation of part names and are not intended to limit the construction of the pump.

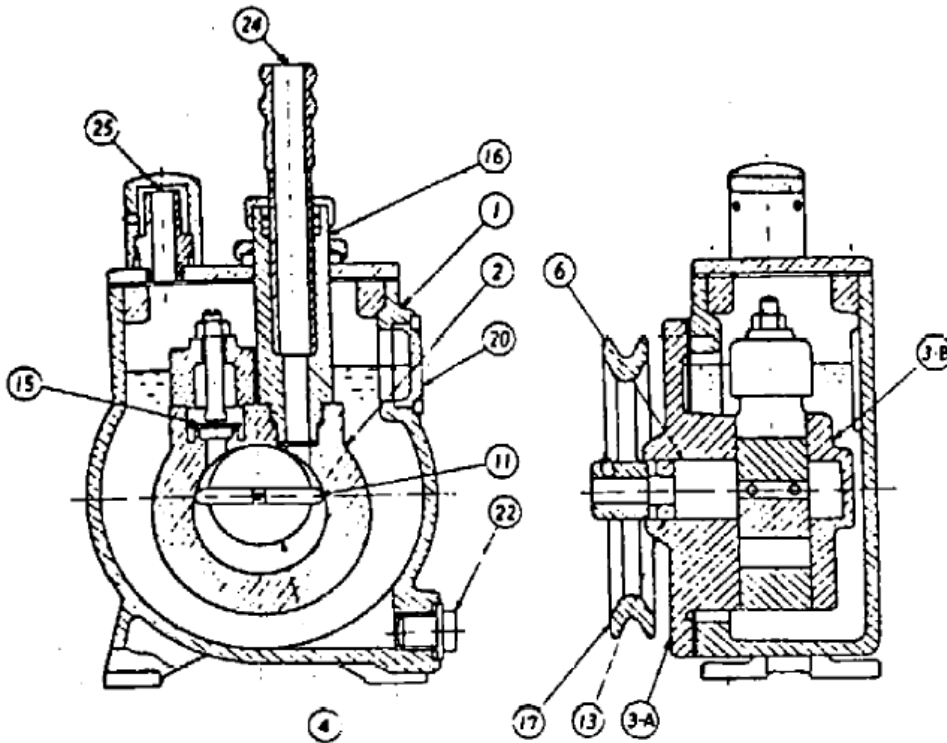

Number	Part name	Number	Part name
1	Case	15	Discharge valve
2	Cylinder	16	Suction pipe
3-A	Front cover	17	Pulley
3-B	Back cover	20	Oil gage
4	Rotor	22	Oil drain plug
6	Main shaft	24	Inlet
11	Blade	25	Outlet
13	Shaft sealing part		

**EXPLANATION FIGURE FOR PART NAMES OF SLIDING VANE TYPE  
OIL-SEALED ROTARY VACUUM PUMP (BELT-DRIVEN)**

**Fig. A1**

**(to be continued)**

Appendix A - (continued)

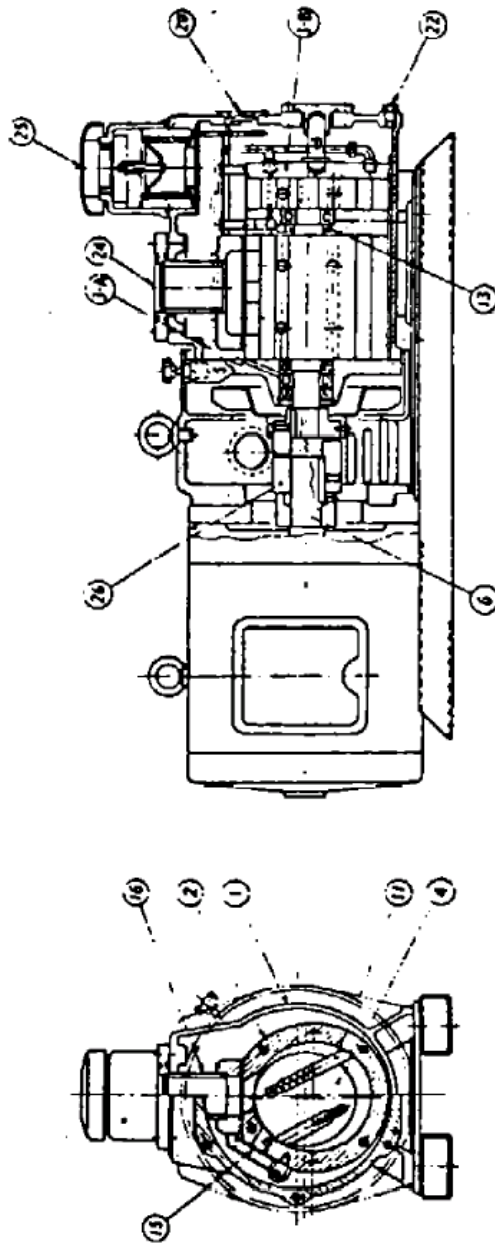

REMARK: This figure is a figure for explanation of part names and is not intended to limit the construction of the pump.

NUMBER	PART NAME	NUMBER	PART NAME	NUMBER	PART NAME
1	CASE	6	Main shaft	20	Oil gauge
2	CYLINDER	11	HUB	22	OIL DRAIN PLUG
3-A	Front cover	13	Shaft sealing section	24	INLET
3-B	BACK COVER	15	DISCHARGE VALVE	25	OUTLET
4	ROTOR	16	SUCTION PIPE	26	COUPLING

EXPLANATION FIGURE FOR PART NAMES OF SLIDING VANE TYPE OIL-SEALED ROTARY VACUUM PUMP (DRIVEN BY SHAFT COUPLING)

Fig. A2

(to be continued)

Appendix A - (continued)

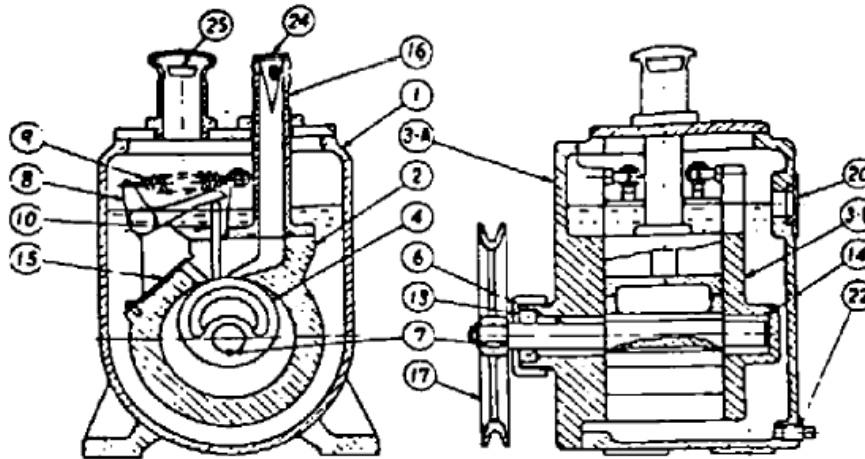

Number	Part name
1	Case
2	Cylinder
3-A	Front cover
3-B	Back cover
4	Rotor
6	Main shaft
7	Key
8	Lever
9	Spring
10	Vane
13	Shaft sealing section
14	Bearing
15	Discharge valve
16	Suction pipe
17	Pulley
20	Oil gage
22	Oil drain plug
24	Inlet
25	Outlet

EXPLANATION FIGURE FOR PART NAMES OF ROTARY PISTON TYPE  
OIL-SEALED ROTARY VACUUM PUMP (BELT-DRIVEN)

Fig. A3

(to be continued)

Appendix A - (continued)

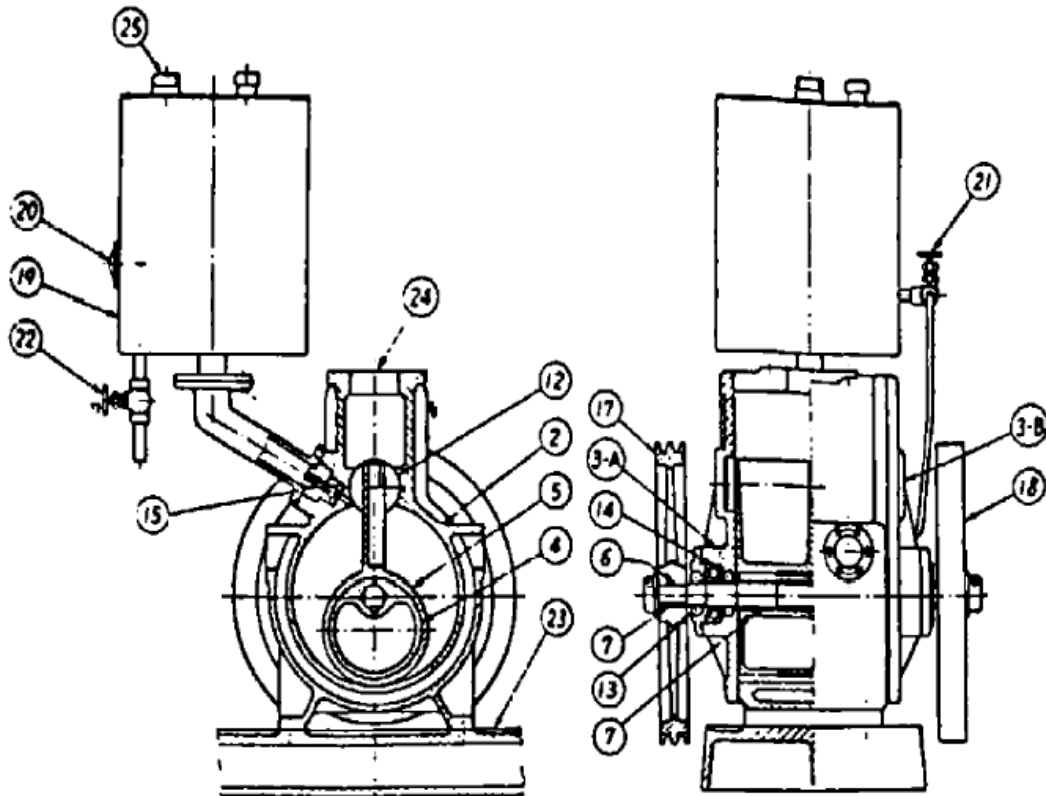

Number	Part name	Number	Part name
2	Cylinder	15	Discharge valve
3-A	Front cover	17	Pulley
3-B	Back cover	18	Flywheel
4	Rotor	19	Oil tank
5	Piston	20	Oil gage
6	Main shaft	21	Oiling valve
7	Key	22	Oil drain valve
12	Slide pin	23	Common bed
13	Shaft sealing part	24	Inlet
14	Bearing	25	Outlet

EXPLANATION FIGURE FOR PART NAMES OF ROTARY PLUNGER TYPE  
OIL-SEALED ROTARY VACUUM PUMP (BELT-DRIVEN)

Fig. A4