

**MATERIAL AND EQUIPMENT STANDARD****FOR****LINE PIPE****FOURTH EDITION****DECEMBER 2020**

**FOREWORD**

The Iranian Petroleum Standards (IPS) reflect the views of the Iranian Ministry of Petroleum and are intended for use in the oil and gas production facilities, oil refineries, chemical and petrochemical plants, gas handling and processing installations and other such facilities.

IPS are based on internationally acceptable standards and include selections from the items stipulated in the referenced standards. They are also supplemented by additional requirements and/or modifications based on the experience acquired by the Iranian Petroleum Industry and the local market availability. The options which are not specified in the text of the standards are itemized in data sheet/s, so that, the user can select his appropriate preferences therein.

The IPS standards are therefore expected to be sufficiently flexible so that the users can adapt these standards to their requirements. However, they may not cover every requirement of each project. For such cases, an addendum to IPS Standard shall be prepared by the user which elaborates the particular requirements of the user. This addendum together with the relevant IPS shall form the job specification for the specific project or work.

The IPS is reviewed and up-dated approximately every five years. Each standards are subject to amendment or withdrawal, if required, thus the latest edition of IPS shall be applicable

The users of IPS are therefore requested to send their views and comments, including any addendum prepared for particular cases to the following address. These comments and recommendations will be reviewed by the relevant technical committee and in case of approval will be incorporated in the next revision of the standard.

Deputy of Standardization, Administrative of Technical, Execution and Evaluation of Projects Affairs,  
No.17, St. 14th, North Kheradmand, Karimkhan Blvd., Tehran, Iran.

Postal Code-1585886851

Tel: 88810459-60 & 66153055

Fax: 88810462

Email: Standards@ nioc.ir

CONTENTS	PAGE No.
<b>PART I</b> .....	<b>1</b>
1. Introduction.....	1
1.1 Scope.....	1
2. General Definitions.....	2
<b>PART II</b> .....	<b>3</b>
2. Normative References.....	3
3. Terms and Definitions, Symbols, and Abbreviations .....	4
3.1.23 HFW Pipe.....	4
3.1.60 Test Unit.....	4
4. Conformity .....	5
4.1 Units of Measurement.....	5
4.2 Rounding.....	5
5. Compliance to this Specification.....	6
5.1 Quality .....	6
5.3 References to Annexes.....	6
5.4 Minimum Inspection Requirements .....	6
6. Pipe Grade, Steel Grade and Delivery Condition.....	7
7. Information to be Supplied by the Purchaser .....	7
7.1 General Information .....	7
7.2 Additional Information.....	7
8. Manufacturing.....	7
8.1 Process of Manufacture .....	7
8.4 Tack Welds.....	10
8.6 Weld Seams in SAW Pipe .....	11
8.8 Treatment of Weld Seams in EW Pipe.....	11
8.8.2 PSL 2 HFW Pipe.....	11
8.9 Cold Sizing and Cold Expansion.....	12
8.11 Jointers.....	12
8.12 Heat Treatment.....	12
8.13 Traceability .....	13
8.14 Preparation of Edges for Welding .....	13
9. Acceptance Criteria.....	13
9.2 Chemical Composition .....	13
9.6 Flattening Test.....	15
9.8 CVN Impact Test for PSL 2 Pipe .....	15
9.10 Surface Conditions, Imperfections and Defects.....	17
9.11 Dimensions, Mass and Tolerances .....	19
9.12 Finish of Pipe Ends.....	20
9.13 Tolerances for the Weld Seam.....	21
9.14 Tolerances for Mass.....	23
9.15 Weldability of PSL 2 pipe .....	23
9.16 Crack Tip Opening Displacement (CTOD) Test (for Fracture Toughness Evaluation) .....	23
9.17 Hardness Survey .....	23
9.18 Spring-back Ring Test for Residual Stress Evaluation.....	24

---

<b>10. Inspection</b> .....	<b>26</b>
<b>10.1 Types of Inspection and Inspection Documents</b> .....	<b>26</b>
<b>10.2 Specific Inspection</b> .....	<b>27</b>
<b>11. Marking</b> .....	<b>35</b>
<b>11.2 Pipe Marking</b> .....	<b>36</b>
<b>14. Pipe Loading</b> .....	<b>38</b>
<b>14.1 General</b> .....	<b>38</b>
<b>14.2 Shipping</b> .....	<b>38</b>
<b>14.3 Handling</b> .....	<b>38</b>
<b>14.4 Storage</b> .....	<b>38</b>
<b>Annex B (Normative) Manufacturing Procedure Qualification for PSL 2 Pipe</b> .....	<b>40</b>
<b>Annex C (Normative) Treatment of Surface Imperfections and Defects</b> .....	<b>51</b>
<b>Annex D (Normative) Repair Welding Procedure</b> .....	<b>53</b>
<b>Annex E (Normative) Nondestructive Inspection for Pipe Not Required to Meet Annex H, J, or N</b> .....	<b>57</b>
<b>Annex H (Normative) PSL 2 Pipe Ordered for Sour Service</b> .....	<b>69</b>
<b>Annex K (Normative) Nondestructive Inspection for Pipe Ordered for Sour Service, Offshore Service, and/or Service Requiring Longitudinal Plastic Strain Capacity</b> .....	<b>79</b>
<b>Appendix 1 (Informative) Welding Consumables</b> .....	<b>84</b>
<b>Appendix 2 (Informative) Weldability Test</b> .....	<b>87</b>
<b>Appendix 3 (Informative) Qualification of NDT at Plate/Coil and Pipe Mills</b> .....	<b>91</b>
<b>Appendix 4 (Informative) Procedure Requirements for NDT</b> .....	<b>96</b>
<b>Appendix 5 (Informative) Minimum Requirements to Order Sour-Service Plate</b> .....	<b>102</b>
<b>Appendix 6 (Informative) Typical MPS/QCP-ITP document</b> .....	<b>104</b>

---

**PART I****1. Introduction**

This Standard specification gives the amendments and supplements to API Spec 5L (Forty-Sixth Edition-2018) "Specification for Line Pipe" named parent standard.

The amendments/supplements to API Spec 5L given in PART II of this Standard are directly related to the equivalent sections or clauses in API Spec 5L. For clarity, the section and paragraph numbering of API Spec 5L has been used as far as possible. Where clauses in API Spec 5L are referenced within this Standard, it shall mean those clauses are amended by this Standard. Clauses in API Spec 5L that are not amended by this Standard shall remain valid as written. Furthermore, in this standard, there are two conditions which will be selected based on the service condition at the COMPANY discretion, as the following:

- a) Unless otherwise specified by the purchaser: It means the clause shall be carried out, unless the purchaser specified another requirement in purchase order or manufacturer documents (i.e. MPS/QCP-ITP etc.) with Company approval.
- b) If specified by the purchaser: It means the clause is not mandatory to carry out, unless the purchaser specified it in purchase order or manufacturer documents (i.e. MPS/QCP-ITP etc.) with COMPANY approval.

Unless defined otherwise in the purchase order, the order of precedence (highest authority listed first) of the documents shall be:

- a) Regulatory requirements.
- b) Contract documentation (e.g. Purchase order, Approved MPS/QCP-ITP or Data sheet).
- c) This specification.
- d) The parent standard.

**Note 1:** This is a revised version of this standard, which is issued as revision (4)-2020. Revision (3)-2014 of the said standard specification is withdrawn.

**1.1 Scope**

This standard specifies requirements for manufacturing of product specification level PSL 2 of seamless and welded pipe (including SAW and HFW) for use in pipeline transportation systems in the petroleum, petrochemical and natural gas industries.

**2. General Definitions**

The users of this Standard shall consider the following definitions:

**COMPANY (means PURCHASER):**

Refers to one of the related and/or affiliated companies of the Iranian Ministry of Petroleum such as National Iranian Oil Company, National Iranian Gas Company, National Petrochemical Company and National Iranian Oil Refinery And Distribution Company that is responsible for the definition of requirements for a product purchase order and for payment of that order.

**VENDOR (means MANUFACTURER):**

Refers to mill that will fabricate the product.

**CONTRACTOR (means SUPPLIER):**

Refers to the persons, firm or company whose tender has been accepted by the COMPANY and who will supply the product.

**INSPECTOR:**

The Inspector referred to in this Standard is a person/persons or a body appointed in writing by the COMPANY for the inspection of fabrication and installation work.

**SHALL:**

Is used where a provision is mandatory.

**SHOULD:**

Is used where a provision is advisory only.

**WILL:**

Is normally used in connection with the action by the COMPANY or its representative in order to future decisions or actions, rather than by a contractor, supplier or vendor.

**MAY:**

Is used where a provision is completely discretionary.

**PART II****2. Normative References****Add to this clause the following:**

API Specification 5L:2018	“Line Pipe”
API RP 5L1	“Recommended Practice for Railroad Transportation of Line Pipe”
API RP 5LT	“Recommended Practice for Truck Transportation of Line Pipe”
API RP 5LW	“Recommended Practice for Transportation of Line Pipe on Barges and Marine Vessels”
ASME BPVC Section II - Part C	“Specifications for welding rods, electrodes and filler metals”
ASME BPVC Section VIII - Div 1	“Rules for construction of pressure vessel”
ASTM E9	“Standard Test Methods of Compression Testing of Metallic Materials at Room Temperature”
ASTM E45	“Standard Test Methods for Determining the Inclusion Content of Steel”
ASTM E112	“Standard Test Methods for Determining Average Grain Size”
ASTM E384	“Standard Test Method for Knoop and Vickers Hardness of Materials”
ASTM E1180	“Standard Practice For Preparing Sulfur Prints For Macrostructural Evaluation”
ASTM E1268	“Standard Practice For Assessing The Degree Of Banding Or Orientation Of Microstructures”
ASTM E1928	“Standard Practice for Estimating the Approximate Residual Circumferential Stress in Straight Thin-walled Tubing”
AWS A4.4M	“Standard Procedures for Determination of Moisture Content of Welding Fluxes and Welding Electrode Flux Coverings”
AWS A5.01/A5.01M	“Filler metal – Procurement guidelines”
AWS A5.1/A5.1M	“Specification for Carbon Steel Electrodes for Shielded Metal Arc Welding”
AWS A5.5/A5.5M	“Specification for Low Alloy Steel Covered Arc Welding Electrodes”
AWS A5.17/A5.17M	“Specification for Carbon Steel Electrodes and Fluxes for Submerged Arc Welding”
AWS A5.18/A5.18M	Specification for Carbon Steel Filler Metal for Gas Shielded Arc Welding.
AWS A5.23/A5.23M	“Specification for Low Alloy Steel Electrodes and Fluxes for Submerged Arc Welding”
AWS A5.28/A5.28M	“Specification for Low Alloy Steel Filler Metal for Gas Shielded Arc Welding”

---

AWS A5.32/A5.32M	“Specification for Welding Shielded Gases”
BS 8701	“Full ring ovalization test for determining the susceptibility to cracking of line pipe steels in sour service - Test method”
DNVGL-ST -F101	“Submarine Pipelines Systems”
EFC Publication 16	“Guidelines on Materials Requirements for Carbon and Low Alloy Steels for H <sub>2</sub> S-Containing Environments in Oil and Gas Production”
ISO 3183:2019	“Petroleum and natural gas industries - Steel pipe for pipeline transportation systems”
ISO 3690	“Welding and allied processes - Determination of hydrogen content in arc weld metal”
ISO 5817	“Welding — Fusion-welded joints in steel, nickel, titanium and their alloys (beam welding excluded) — Quality levels for imperfections”
ISO 10005	“Quality management-Guidelines for quality plans”
ISO 14732	“Welding personnel - Qualification testing of welding operators and weld setters for mechanized and automatic welding of metallic materials”
ISO 17637	“Non-destructive testing of welds - Visual testing of fusion-welded joints”
ISO 17639	“Destructive tests on welds in metallic materials - Macroscopic and microscopic examination of welds”
ISO 17640	“Non-destructive testing of welds-Ultrasonic testing - Techniques, testing levels, and assessment”
IPS-E-GN-100	“Engineering Standard for Units”
NACE MR0175/ ISO 15156	“Petroleum and natural gas industries - Materials for use in H <sub>2</sub> S containing environments in oil and gas production”
NACE TM0316	“Four-Point Bend Testing of Materials for Oil and Gas Applications”

### 3. Terms and Definitions, Symbols, and Abbreviations

#### 3.1.23 HFW Pipe

##### High-frequency welded pipe

**The existing clause shall be deleted and replaced with the following:**

Unless otherwise specified by the purchaser, EW pipe produced with a welding current frequency equal to or greater than 150 KHZ.

#### 3.1.60 Test Unit

**The existing clause shall be deleted and replaced with the following:**

Prescribed quantity of finished pipe that is made to the same specified outside diameter and specified wall thickness, from strip(coils)/plates/billets produced by the same hot rolling practice (as applicable to welded pipe), from the same pipe-manufacturing process from the same heat and under the same pipe-manufacturing conditions. According to each of the following conditions,



---

requires the creation of a new test unit unless otherwise specified in this standard:

- I. Changing pipe-manufacturing process and conditions.
- II. The pipes subject to any reprocessing.
- III. Changing each Heat No.
- IV. An increase or decrease in the cold-expansion ratio of more than 0.002.
- V. Producing pipes with the same conditions:
  - Not more than 200 pipes with  $OD \leq 6"$ .
  - Not more than 100 pipes with  $6" < OD < 20"$ .
  - Not more than 50 pipes with  $OD \geq 20"$ .

**Add to clause 3.1, the following:**

**3.1.66 Tolerance:** Allowable plus or minus amount for a specific value.

**3.1.67 Variation:** A total allowable range for a value.

**3.1.68 Datum:** A basis amount for a value.

**3.1.69 Charge:** The product produced by a single cycle of process (e.g. heat treatment, casting sequence/strand).

**Add to clause 3.3, the following:**

**MPS:** Manufacturing Procedure Specification.

**QCP:** Quality Control Plan.

**ITP:** Inspection and Testing Plan.

**MPQT:** Manufacturing Procedure Qualification Tests (may be first day production testing).

**PIM:** Pre-Inspection Meeting.

**NCR:** Nonconformance request.

## **4. Conformity**

### **4.1 Units of Measurement**

**The existing clause shall be deleted and replaced with the following:**

This Standard is based on International System of Units (SI), as per [IPS-E-GN-100](#) except where otherwise specified.

### **4.2 Rounding**

**The existing clause shall be deleted and replaced with the following:**

Unless otherwise stated in this Standard, to determine conformance with the specified requirements, observed or calculated values shall be rounded to the nearest unit in the last right-hand place of figures used in expressing the limiting value, in accordance with [IPS-E-GN-100](#), part 5.6 "Guide for the Rounding of Numbers".

---

## 5. Compliance to this Specification

### 5.1 Quality

#### **Add to this clause the following:**

The manufacturer shall be previously audited or accepted by the purchaser.

All sub-contractors (e.g. raw material supplier, NDT supplier, etc.) shall be clearly identified (unless defined otherwise at the bid stage) and accepted by the purchaser.

Quality plans and inspection and test plans, developed as outputs to operational planning and control for the products and services, shall define the specific controls to be implemented by the manufacturer and when applicable sub-manufacturers to ensure conformance with the specified requirements. Controls shall address both internally and externally sourced processes products and services.

### 5.3 References to Annexes

#### **Add to this clause the following:**

**Note 1:** Informative Appendixes as the following may be used:

- a) Welding consumables, see Appendix 1.
- b) Weldability test, see Appendix 2.
- c) Qualification of NDT at plate/ strip (coil) and pipe mill, see Appendix 3.
- d) NDT procedure minimum content, see Appendix 4.
- e) Minimum requirements to order sour-service plate, see Appendix 5.
- f) Typical MPS/QCP-ITP document, see Appendix 6.

### 5.4 Minimum Inspection Requirements

#### **Add this clause as the following:**

The manufacturer shall notify the purchaser and inspector with a sufficient notice period to enable their attendance at qualification tests, and at all other tests or stages of manufacture which are subject to acceptance in accordance with this specification. The notice period for intervention points shall be agreed at the Pre-Inspection Meeting (PIM).

The manufacturer shall ensure that the purchaser and the inspector have full and free access to all parts of the mill during all manufacturing and inspection stages, without interfering with normal mill production.

Where the mill country language is not English, all procedure required for review and all tests certificates shall be written in two languages, i.e. the native language of the country in which the mill is located and English.

If during the main production more than 10 % of the pipes are rejected in any single day's production or re-routed for repairs or re-processing, the purchaser or inspector shall have the right to instruct the manufacturer to increase his quality control program to an appropriate level, and to maintain it at that level until the causes of the defective quality are identified and eliminated. A corrective action request will be sent by the inspector to the manufacturer. Production will not be accepted until a response with positive results is accepted by inspector.

If the above reaches 15 %, the purchaser or inspector may require the main production to be stopped. In such a case, the purchaser is entitled to require a program of investigation to determine the root cause of the defective quality. This program will be established in mutual agreement between the purchaser and the manufacturer. The rest of production shall be put on hold until the investigations are concluded and the purchaser has accepted that production can be resumed.

**Note 1:** An indication found but later cleared by additional NDT checks shall not be part of the above repair rate ratio.

At the end of the manufacturing activities and tests, the manufacturer shall provide a test report (and graphs for hydrotest and heat treatment) giving the results information. Finally, manufacturer shall prepare a final book of all manufacturing activities and tests associated with product certificates.

Any work performance or test result not in conformance with the purchaser's specifications or agreed procedure shall be subject to a nonconformance request (NCR), to be issued by the manufacturer for the purchaser's acceptance. Each NCR report shall state the corrective action proposed by the manufacturer. A NCR process including lead times for issue and response shall be agreed at the Pre-Inspection Meeting (PIM).

## 6. Pipe Grade, Steel Grade and Delivery Condition

### Add to this clause the following:

6.1.4 Intermediate grades are not acceptable and all related clauses shall be ignored.

## 7. Information to be supplied by the Purchaser

### 7.1 General Information

#### Add to this clause the following:

i) Minimum and maximum design temperature.

### 7.2 Additional Information

#### Add to item b of this clause, the following:

17) The requirement for bevel protector.

## 8. Manufacturing

### 8.1 Process of Manufacture

#### Add to this clause the following:

Any change to the essential manufacturing process parameters beyond the limit qualification of the MPQT shall require requalification (see Annex B).

**Note 1:** Type of pipes including COW, COWL, COWH, LFW, LW, Double-seam SAWL and Double-seam COWL are not acceptable and all related clauses shall be ignored.

**Note 2:** COW may be acceptable only for making a continuous tack weld in SAW pipe.

**Note 3:** HFW pipe is generally limited to a maximum wall thickness 20 mm.

**Note 4:** For type of pipe end, only plain end and beveled end are acceptable.

**Note 5:** For using of SAWH pipes design principles shall be considered and specified by the purchaser based on the service condition. SAWH pipe is generally manufactured where the outer diameter is equal and above 24" (610 mm).

Unless otherwise specified by the purchaser, SAWH pipes shall be manufactured by offline manufacturing process (i.e. helical two-step (HTS)); this process is split into pipe forming combined with continuous tack welding followed by submerged arc welding.

SAWH line pipe shall not be used for any of the following applications:

- a) Where the seam welds are at risk of corrosion due to water drop out.
- b) In sour service.

**8.3.2 The existing clause shall be deleted and replaced with the following:**

The ingots, blooms, billets, slab, strip (coil) or plates used as starting material for the manufacture of pipe shall be made in a basic oxygen or electric arc furnace.

Slitting of mother plate/ strip (coil) or slabs should not carried out.

**Note 1:** If slitting allowed by the purchaser based on the service condition, at least the following precautions shall be considered:

- Metallographic investigations (including e.g. micro and if required macro and hardness) shall be applied to determine the wide of segregation zone throughout full wide of mother plate/ strip (coil) or slabs.
- Center slitting of mother plate/ strip (coil) or slabs and slitting through segregation zone are not permitted (due to adverse effects of probable segregations).
- Slitting may be performed such that a suitable distance between "segregation zone" and "weld area (including seam and HAZ)" be at least 5 times of nominal wall thickness of pipe (i.e. 5t). The suitable distance may be varied at the COMPANY discretion based on metallographic investigations and service condition.
- If there is no observable segregation zone through metallographic investigations, the suitable distance (i.e. 5t or specified by the purchaser) shall be applied between center line of "mother plate/ strip (coil) or slabs" and "weld area (including seam and HAZ)".
- Metallographic investigations shall be carried out at least once for each slitting.

**Note 2:** Strip (coil)/plate end welds are not permitted and related clauses shall be ignored.

**8.3.3 The existing clause shall be deleted and replaced with the following:**

The manufacturer shall demonstrate that clean steel making practices are used and specific treatment to control inclusions size, shape and distribution are employed to produce the quality steel required to manufacture the pipes according to this specification. For HFW pipes, inclusion control with respect to content, distribution and shape shall be performed by desulfurizing, degassing, and either calcium injection or rare earth metal treatment.

The manufacturer shall record details of the casting sequences (e.g. casting strand, number of heats, tons, scrapping lengths). These parameters shall be available for inspector review, if requested.

In addition, the following requirements shall be considered and reported, unless otherwise specified by the purchaser:

- a) If steel scrap is used, delivered scrap shall be checked for radioactivity; no radiation is permitted.
- b) The steel shall be fully killed.
- c) The gas content of Oxygen, Hydrogen and Nitrogen within molten steel or product shall be checked online (and documented) and be equal or less than 30 ppm, 5 ppm and 120 ppm, respectively.

The inspection frequency shall be at least one sample per heat No. under the same manufacturing conditions.

- d) Sulfur print testing should be carried out for the slab used for the manufacture of pipe, according to ASTM E1180 to reveal the segregation and distribution of sulfide inclusions to ensure the uniformity of productions. The test results shall not exhibit long continuous or accumulated segregations d) Any other acceptance criteria or sulfur print pattern (or method) shall be specified by the purchaser if required based on the service condition.

Suitable inspection frequency shall be specified by the purchaser based on the service condition; unless otherwise specified by the purchaser, the inspection frequency shall be at least one

sample per each ten heat No. or charge No. (whichever applicable) under the same manufacturing conditions (For sour service frequency, see H.3.2.1).

Segregation analysis shall be carried out for the slab used for the manufacture of pipe, by cross-section chemical analysis at least at the surface,  $\frac{1}{4}$  and  $\frac{1}{2}$  product thickness. The chemical composition shall be within the variation of target chemical composition (See B.5.2.1).

Suitable inspection frequency shall be specified by the purchaser based on the service condition; unless otherwise specified by the purchaser, the inspection frequency shall be at least one sample per each ten heat No. or charge No. (whichever applicable) under the same manufacturing conditions (For sour service frequency, see H.3.2.1).

**Note 1:** Macrographic and micrographic methods associated with a suitable inspection frequency and criteria to evaluate the uniformity of productions may be specified by the purchaser if required based on the service condition.

e) The steel used for the manufacture of pipe shall be fine grained with a grain size of ASTM No.8 or finer, as defined in ASTM E112. Generally, this grain size criteria is for steels including ferrite-pearlite microstructures; and for other microstructures (as primary austenite grain size in a full martensitic microstructure steel, etc.), the grain size criteria shall be specified by the purchaser if required.

Suitable inspection frequency shall be specified by the purchaser based on the service condition; unless otherwise specified by the purchaser, the inspection frequency shall be at least one sample per each ten heat No. or charge No. (whichever applicable) under the same manufacturing conditions.

**Note 1:** Grain size measurement for SMLS and welded pipes shall also be carried out after final mechanical and thermal processes of pipe manufacturing, to ensure achieving a grain size of ASTM No.8 or finer.

f) The steel used for the manufacture of pipe shall be examined at least at location  $\frac{1}{4}$  and  $\frac{1}{2}$  product thickness for a banded structure in terms of "carbon / carbides segregation" and "ferrite or pearlite/martensite, etc" and qualified under the responsibility of the pipe manufacturer. Assessing the nature, extent and degree of banding or orientation for single-phase (constituent) and two or more phases (constituents) microstructures shall be carried out as stereological or microindentation hardness procedures whichever is applicable as defined in ASTM E1268 to ensure the uniformity of productions. Furthermore, the acceptance criteria may be specified by the purchaser if required based on the service condition.

Suitable inspection frequency shall be specified by the purchaser based on the service condition; unless otherwise specified by the purchaser, the inspection frequency shall be at least one sample per each ten heat No. or charge No. (whichever applicable) under the same manufacturing conditions. (For sour service frequency, see H.3.2.1)

**Note 1:** Bidirectional mechanical test (including at least tensile and CVN impact tests) associated with a suitable inspection frequency may be specified by the purchaser if required based on the service condition to ensure achieving fairly isotropic mechanical properties; The results shall be within the tolerance of target mechanical properties.

Unless otherwise specified by the purchaser, the inspection frequency shall be at least one sample per each ten heat No. or charge No. (whichever applicable) under the same manufacturing conditions.

**Note 2:** The degree of banding or orientation of microstructure measurement (and bidirectional mechanical tests, if required by the purchaser) for SMLS and welded pipes shall also be carried out after final mechanical and thermal processes of pipe manufacturing to ensure achieving acceptance criteria.

g) The steel used for the manufacture of pipe shall not have detrimental inclusions contents with the following considerations. The inclusion rating shall be performed in accordance with the microscopical test method of ASTM E45 (Method D: Low Inclusion Content) and shall not be

higher than severity 1.5 for all types of heavy and thin inclusions (i.e. types A, B, C and D inclusions). Any other acceptance criteria (severity) may be specified by the purchaser for each type of inclusions or even all of them if required based on the service condition.

Suitable inspection frequency shall be specified by the purchaser based on the service condition; Unless otherwise specified by the purchaser, the inspection frequency shall be at least one sample per each ten heat No. or charge No. (whichever applicable) under the same manufacturing conditions (For sour service frequency, see H.3.2.1).

**Note 1:** The microscopical test method D for inclusion rating of steel for SMLS and welded pipes shall also be carried out after final mechanical and thermal processes of pipe manufacturing to ensure achieving acceptance criteria.

**8.3.6 The existing clause shall be deleted and replaced with the following:**

Any lubricant or contamination on the weld bevel or the surrounding areas [minimum 100 mm (3.937 in.)] shall be removed before making the seam welds (tack weld and SAW weld). The weld bevel shall be clean and completely dry.

**8.3.10 Add this clause as the following:**

Regarding to inspection documents for plate/strip (coil), the manufacturer shall issue a 3.1 inspection certificate in accordance with ISO 10474 or EN 10204.

Alternatively, if specified by the purchaser, a 3.2 inspection certificate in accordance with ISO 10474 or EN 10204 shall be issued.

Format of mill certificates shall be agreed between the purchaser and the manufacturer prior to the start of production. The mill certificates shall identify the heat and slab from which each plate or strip (coil) was produced. Mill certificates shall clearly indicate the as-delivered condition of product (e.g. normalized, controlled rolled with accelerated cooling).

In all cases, reports of all tests and inspections carried out on plates and strip (coils) shall be prepared. The reports shall include results of the following:

- a) Heat and product analyses.
- b) Mechanical tests.
- c) Through thickness metallographic examination.
- d) Visual inspection.
- e) Thickness measurements.
- f) Ultrasonic inspection.

**8.3.11 Add this clause as the following:**

Each side of the plate or strip (coil) shall be removed by machining or shearing for at least 10 mm or 1.5 times the wall thickness, whichever is greater. If the removing each side of the plate or strip (coil) is not within the steel manufacturer's scope, it shall be carried out by pipe manufacturer.

## 8.4 Tack Welds

**Add to this clause the following:**

Manual welding is allowed but shall be restricted to pipe ends.

**8.4.1 e: The existing clause shall be deleted and replaced with the following:**

---

Shielded metal arc welding using low hydrogen electrodes from which the diffusible hydrogen content of the resulting weldment shall not exceed 5 ml/100g of deposited metal.

#### **8.4.3 Add this clause as the following:**

Repair of a tack weld by manual welding is permitted provided that the weld is ground down to the thickness of the automatic pass.

### **8.6 Weld Seams in SAW Pipe**

#### **The existing clause shall be deleted and replaced with the following:**

For the production of weld seams in SAW pipe, the first pass shall be made on the inside of the pipe and at least one submerged-arc welding pass shall be made on the outside of the pipe.

Unless otherwise agreed by the purchaser, run-on and run-off tabs shall always be used. Run-on and run-off tabs shall be grooved to match the seam weld groove geometry. If not grooved, the pipe ends shall be cropped off. Tabs length shall be sufficient to establish the arc regime and ensure completion of welding outside the pipe seam. After completion of the longitudinal seam weld, the run-on and run-off tabs shall be removed. Mechanical breaking of tabs is not allowed.

#### **Note 1:** For SAW pipe:

Welding equipment shall include a weld seam tracking system to ensure complete interpenetration and overlap of the inside and outside welds.

#### **Note 2:** Flux coverage:

- a) Flux coverage of all arcs is mandatory. Visible arcs are not permitted.
- b) If specified by the purchaser, the flux shall meet the requirements of Appendix 1.

### **8.8 Treatment of Weld Seams in EW Pipe**

#### **8.8.2 PSL 2 HFW Pipe**

#### **The existing clause shall be deleted and replaced with the following:**

For each grade which is not subjected to quench and temper processing, the full thickness of the weld seam and HAZ shall be normalized above the upper critical transformation temperature of the steel.

The heat treatment area shall be extended to the base metal by the lesser of 30 mm (1.18 in.) or twice the pipe wall thickness measured on the internal surface.

Cooling by water is permitted when this area has a temperature of 250 °C (482 °F) or below, unless qualified to allow a higher temperature prior to water cooling by purchaser approval.

Weld seam heat-treating equipment shall include a weld seam tracking system to ensure full coverage of the weld:

- a) This system shall be reviewed and accepted by the purchaser.
- b) Heat treatment temperature shall be continuously monitored and recorded.
- c) The records shall be available for review by the third-party inspector during production and until the order is shipped.

Failure or abnormal operation of the seam heat treatment equipment, including the seam tracking and heating elements, shall trigger an alarm and automatic pipe marking.

If the seam heat treatment temperature does not meet the control range, such portions shall be discarded.

## 8.9 Cold Sizing and Cold Expansion

### Add to this clause the following:

The sizing ratio shall be recorded for three pipes per shift (at the beginning, middle and end of shift) or every 20 pipes per shift, whichever is lesser and also on the MPQT pipe used for qualification of the MPS.

### 8.9.2 The existing clause shall be deleted and replaced with the following:

The sizing ratio for cold-expanded pipe shall not be less than 0.008 or more than 0.015.

**Note 1:** Non-expanded SAW pipe shall not be supplied unless explicitly stated on the purchase order together with any supplementary test requirements. HFW shall not be cold expanded.

**Note 2:** Unless otherwise specified by the purchaser, non-expanded pipes manufactured by press or roll bending processes are not acceptable unless full body heat treatment is performed.

**Note 3:** Unless otherwise specified by the purchaser, HFW and SAWH shall not be cold expanded.

## 8.11 Jointers

### The existing clause shall be deleted and replaced with the following:

Jointers shall not be supplied and all related clauses shall be ignored.

## 8.12 Heat Treatment

### The existing clause shall be deleted and replaced with the following:

Heat treatments shall be performed based on documented procedures and reported with a chart.

Furnace surveys shall be done at least once per year in accordance with an industry recognized standard e.g. NORSOK, ISO, API, ASTM, etc provided a certificate including at least the following, unless otherwise specified by the purchaser:

a) For austenitizing furnaces, temperature uniformity shall be  $\pm 14$  °C ( $\pm 25$  °F).

b) For tempering furnaces, temperature uniformity shall be  $\pm 8$  °C ( $\pm 15$  °F).

Furnaces shall be equipped with recording sensors that are calibrated at least quarterly. For quenching facilities, the coolant temperature shall be continuously monitored and remain below 40 °C (104 °F).

Essential variables including nozzle size, water flow rate and quenching conveyor speed shall be controlled for each production size.

**Note 1:** Unless otherwise specified by the purchaser, pipe with  $\frac{D}{t} \leq 20$  shall be subject to stress relief heat treatment; otherwise, a strain-ageing test shall be carried out according to a procedure with COMPANY's approval (see B.5.2.5).

**Note 2:** MPQT shall be performed in the stress relief condition.

Unless otherwise specified by the purchaser, stress relief heat treatment should be performed by heating the pipe in accordance with the following:

a) 20 °C (68 °F) lower than the mill tempering temperature for pipe with delivery condition QT or NT;

b) The temperature should not be above 580 °C (1076 °F) for pipe with delivery condition M (Regarding Clause 3.1.61). If manufacturer demonstrated that higher temperature cannot lower the strength values, the temperature may be above 580 °C (1076 °F) but should not be above 595 °C (1103 °F).



**Note 3:** See ASME Section VIII - Division 1- UCS-56 for details of stress relieve heat treatment variables and tolerances.

**Note 4:** Unless otherwise specified by the purchaser, for sour service and demanding applications, quenching by spraying is not recommended.

### 8.13 Traceability

#### **Add to this clause the following:**

The manufacturer shall record the following heat identity properties, as applicable:

- a) Date of production.
- b) Casting sequence number.
- c) Heat number.
- d) Casting strand number.
- e) Billet/slab sequence number.
- f) Mother billet/slab (If applicable).
- g) Daughter billet/slab (If applicable).
- h) Mother pipe/plate (If applicable).
- i) Test unit identity.
- j) Pipe numbering.

### 8.14 Preparation of Edges for Welding

#### **Add this clause as the following:**

The edges of the plates or strip (coil) to be welded shall be profiled by machining. The abutting edges of the plate or strip (coil) shall be aligned for welding and adequate provision shall be made to ensure that the alignment is maintained during the progress of the welding operation and that any root gap is controlled within limits approved in the procedure test. All surfaces to be welded shall be thoroughly cleaned of scale, oil and other foreign matter before welding is started. The weld shall be of uniform width and profile and shall merge smoothly into the surface of the strip (coil) without appreciable deviation from the line of the joint. The forming procedure must ensure that there is a minimum of peaking and this shall be demonstrated in the procedure test to be within the acceptable limits defined in Clause 9.10.5.

## 9. Acceptance Criteria

### 9.2 Chemical Composition

#### **9.2.2 The existing clause shall be deleted and replaced with the following:**

For PSL 2 pipe with  $t \leq 25.0$  mm (0.984 in.), the chemical composition for standard grades shall be as specified in Table 5.

**Note 1:** The weight percentage of elements for all pipes:

$$S \leq 0.010 \quad P \leq 0.020$$

Unless otherwise specified by the purchaser: For  $S \geq 15$  ppm:  $Ca/S = 2$  to  $5$  with  $Ca \leq 0.004$

Unless otherwise specified by the purchaser: For  $S < 15$  ppm:  $0.001 \leq Ca \leq 0.004$

**Note 2:** In footnote "a" of Table 5, for seamless pipe with  $t > 20.0$  mm (0.787 in), the carbon

equivalent limits shall be 0.43, unless otherwise specified by the purchaser.

**Note 3:** Footnotes "c", "e", "f", "g", "h", "i" and "k" of Table 5 shall be carried out unless otherwise specified by the purchaser.

**Note 4:** In footnote "l" of Table 5, unless otherwise specified by the purchaser:  $B \leq 0.0005$ .

The manufacturer shall declare the target chemical composition and proposed range prior to order placement. Permissible range variations are stated in Table 28, however in no case shall the chemical composition be outwith the limitations of Table 5. After order placement, any change shall be subject to the purchaser's acceptance.

The chemical composition of the MPQT and the product analysis shall be within the target composition declared by the manufacturer. The chemical composition recorded for the pipes used in first-day production testing (i.e. MPQT) shall set the datum CE. The manufacturer shall control the listed chemical elements even if the elements are considered as not intentionally added.

Elements not intentionally added shall be declared; unless otherwise specified by the purchaser, the maximum working percentages of residual elements shall be as follows (ladle and product check):

- Sn  $\leq 0.015$       Pb  $\leq 0.005$
- Sb  $\leq 0.010$       As  $\leq 0.015$
- Bi  $\leq 0.005$       B  $\leq 0.0005$  (i.e. no deliberate addition)

Where any of the elements in Table 28 are not intentionally added, the manufacturer may propose maximum values for approval by the purchaser. The intentionally added elements that are not specified in Table 28 and Table 5 are not permitted without COMPANY's approval.

Product analysis shall be performed under the responsibility of the pipe manufacturer.

**Table 28 - Chemical Composition Allowable Range variations (Weight Percentage)**

Element	Allowable Range variation	Element	Allowable Range variation
C	0.040	Cr	0.100
Mn	0.200	P	NA
Si	0.250	S	NA
Ni	0.100	Ca	NA
Cu	0.060	B	NA
V	0.030	O	NA
Nb	0.020	H	NA
Al	0.040	N	NA
Ti	0.014	CE <sub>IW</sub> <sup>a</sup>	0.060
Mo	0.100	CE <sub>PCM</sub> <sup>a</sup>	0.040

**a.** For CE<sub>IW</sub> and CE<sub>PCM</sub> the range shall be split equally around the datum CE (agreed target value).  
(Allowable range: Target CE<sub>IW</sub>  $\pm$  0.030 and CE<sub>PCM</sub>  $\pm$  0.020)

**9.2.3 The existing clause shall be deleted and replaced with the following:**

For PSL 2 pipe with  $t > 25.0$  mm (0.984 in.), the chemical composition shall be agreed with the purchaser, this standard and with the requirements of Table 5 being amended as appropriate.

**9.2.5 Add to this clause the following:**

Unless otherwise specified by the purchaser, the carbon equivalent limits for grades L415N or X60N and L555Q or X80Q of seamless pipes shall be  $CE_{IIW}=0.43$  and  $CE_{Pcm}=0.25$ .

**9.3 Tensile Properties****9.3.2 Add to this clause the following:**

Unless otherwise specified by the purchaser, maximum ratio  $R_{t0.5} / R_m$  in Table 7, for pipe grades from B to X65 shall be changed to 0.90.

**Add to footnote f in Table 7, the following:**

The specified minimum elongation,  $A_r$ , not be less than 20%.

**Add footnote i to Table 7:**

**Footnote i:** Unless otherwise specified by the purchaser, the measured yield strength values shall not exceed the minimum values which are indicated in Table 7, by more than 120 MPa.

**Note 1:** If specified by the purchaser, tensile testing shall be performed at maximum design temperature and the acceptance criteria shall be in accordance with specified given value and the design code.

**9.6 Flattening Test****The existing clauses shall be deleted and replaced with the following:**

Unless otherwise specified by the purchaser, acceptance criteria for flattening tests shall be as following:

- a) No cracks or breaks shall occur in either weld or parent metal during flattening of the test specimen to 50 % of the original outside diameter.
- b) The specimen shall be further flattened to 33 % of original outside diameter without cracks or breaks, other than in the weld.
- c) There shall be no evidence of lamination or burnt metal during the entire test before opposite walls of the pipe meet.

**9.8 CVN Impact Test for PSL 2 Pipe****9.8.1.2 The existing clause shall be deleted and replaced with the following:**

Individual test values for any test piece shall be  $\geq 80\%$  of the required minimum average (of a set of three test pieces) absorbed energy value. From the set of three Charpy V-notch specimens, only one is allowed to be below the specified average value and shall meet the minimum single value requirement.

**9.8.2 Pipe Body Tests**

**9.8.2.1 The existing clause shall be deleted and replaced with the following:**

For a set of three test pieces, the minimum average absorbed energy for each pipe body test shall be as given in Table 8, based upon full-size test pieces and a test temperature as specified in Table 29.

**Table 29 - CVN impact testing temperature.**

Nominal Wall Thickness (mm)	Test Temperature <sup>a</sup> (°C)	Maximum Test Temperature (°C)
t ≤ 20	T <sup>b</sup>	0
20 < t ≤ 30	T-10	0
30 < t	T-20	0

a. A lower test temperature may be specified by the purchaser  
b. "T" is the minimum design temperature, which shall be specified in the purchase order. If no minimum design temperature is indicated, it shall be taken as 0 °C.

**The existing Table 8 shall be deleted and replaced with the following:**

**Table 8- CVN minimum average absorbed energy for pipe body, weld and HAZ of PSL 2 pipe**

Specified Outside Diameter <i>D</i> mm (in.)	Full-size CVN Absorbed Energy Min. Avg. Kv J (ft-lbf)							
	Grade							
	≤ L390 or X56	> L390 or X56 to ≤ L415 or X60	> L415 or X60 to ≤ L450 or X65	> L450 or X65 to ≤ L485 or X70	> L485 or X70 to ≤ L555 or X80	> L555 or X80 to ≤ L625 or X90	> L625 or X90 to ≤ L690 or X100	> L690 or X100 to ≤ L830 or X120
≤ 508 (20.000)	40 (30)	45 (34)	45 (34)	54 (40)	54 (40)	60 (44)	60 (44)	60 (44)
> 508 (20.000) to 762 (30.000)	40 (30)	45 (34)	45 (34)	54 (40)	54 (40)	60 (44)	60 (44)	60 (44)
> 762 (30.000) to 914 (36.000)	40 (30)	45 (34)	45 (34)	54 (40)	54 (40)	60 (44)	60 (44)	60 (44)
> 914 (36.000) to 1219 <(48.000)	40 (30)	45 (34)	45 (34)	54 (40)	54 (40)	60 (44)	60 (44)	68 (50)
≥ 1219 (48.000) to 1422 (56.000)	40 (30)	45 (34)	54 (40)	68 (50)	68 (50)	68 (50)	68 (50)	81 (60)
> 1422 (56.000) to 2134 (84.000)	40 (30)	45 (34)	68 (50)	81 (60)	81 (60)	81 (60)	95 (70)	108 (80)

**9.8.2.2 The existing clause shall be deleted and replaced with the following:**

For a set of three test pieces, the minimum average and individual shear fracture area for each test shall be at least 85 % and 75 % respectively, at the test temperature specified in Table 29.

**9.8.3 Pipe Weld and HAZ Tests****The existing clause shall be deleted and replaced with the following:**

The minimum average (of a set of three test pieces) absorbed energy for each pipe weld and HAZ test shall be as specified in Table 8, based upon full-size test pieces and test temperature specified in Table 29.

If specified by the purchaser, for a set of three test pieces, the minimum average and individual shear fracture area for each test shall be at least 75 % in the HAZ and 50 % in the weld, at the test temperature specified in Table 29.

**9.9 DWT Test For PSL 2 Pipe****9.9.1 The existing clause shall be deleted and replaced with the following:**

DWT test shall be carried out for all welded pipes with  $D \geq 406$  mm (16 in.). If specified by the purchaser, DWT test may be performed on seamless pipes.

For each test (of a set of two test pieces), the average shear fracture area shall be  $\geq 85$  %, based on 0 °C or minimum design temperature whichever is lesser. The minimum individual shear area value shall be at least 75%.

Full wall thickness specimens shall be used, as far as possible; Where it is not possible to test a full thickness specimen due to capacity limitation of testing equipment, the test temperature shall be adjusted in accordance with API 5L3. DWT temperature reduction for a specimen with a thickness greater than 39.7 mm shall be specified by the purchaser.

**9.10 Surface Conditions, Imperfections and Defects****9.10.1.1 Add to this clause the followings:**

The external surface of all seamless pipes shall be free from scabs, laps, shells, slivers, burrs, metallurgical tears and sharp edged discontinuities that may interfere with the application of thin film [e.g. fusion bonded epoxy (FBE)] coatings, and multi-layer coatings where FBE forms the first layer.

**9.10.1.4 Add this clause as the following:**

The pipe shall be substantially free of loose scale as assessed by the inspector.

**9.10.2 Undercuts****The existing paragraphs shall be deleted and replaced with the followings:**

Undercuts in SAW pipe shall be investigated, classified, and treated as following:

- a) Undercuts that have a depth  $\leq 0.4$  mm (0.008 in.) are acceptable, regardless of length, and shall be treated in accordance with Clause C.1.
- b) Undercuts that have a depth  $> 0.4$  mm (0.008 in.) but  $\leq 0.8$  mm (0.031 in.) are acceptable provided they are treated in accordance with Clause C.2 and provided that:
  - 1) their individual lengths are  $\leq 0.5t$ ,
  - 2) their individual depths are  $\leq 0.1t$ , and
  - 3) there are no more than two such undercuts in any 300 mm (11.811 in.) length of weld.

c) Undercuts that exceed the limits specified in item "b" shall be classified as defects and shall be treated in accordance with Clause C.3.

**Note 1:** Undercuts can best be located visually.

**Note 2:** Undercuts which are coincident at inside and outside weld are not permitted.

**Note 3:** Undercut repairs after pipe expansion is not accepted.

#### 9.10.4 Lamination

**The existing paragraph shall be deleted and replaced with the following:**

Any laminations or inclusions extending into the face or bevel of the pipe shall be classified as a defect. Pipes that contain such defects shall be rejected or cut back until no such lamination or inclusion is present at the pipe ends.

#### 9.10.5 Geometric Deviations

**9.10.5.1 The existing clause shall be deleted and replaced with the following:**

Other than for dents, geometric deviations from the normal cylindrical contour of the pipe (e.g. flat spots and peaks) that occur as a result of the pipe forming process or manufacturing operations, shall be considered defects and treated in accordance with subclauses "b" or "c" of Clause C.3. This applies only to those deviations that exceed:

- a) 3.2 mm (0.126 in.) in depth (measured as the gap between the extreme point of the deviation and the prolongation of the normal contour of the pipe); or
- b) 25 % of pipe diameter or 300 mm (11.811 in.) in length, in any direction whichever is smaller.

**9.10.5.2 The existing clause shall be deleted and replaced with the following:**

For dents, the length in any direction shall be  $\leq 25$  % of the pipe diameter with a maximum length of 300 mm (11.811 in.). The depth, measured as the gap between the extreme point of the dent and the prolongation of the normal contour of the pipe, shall be in accordance with the following:

- a) No sharp-bottom dents are acceptable. For sharp bottom gouges, see 9.10.7.
- b) Cold formed dents without sharp bottom gouges are acceptable to a maximum depth of 3.2 mm (0.126 in.).
- c) Dents  $> 1.6$  mm (0.063 in.) are not acceptable at the pipe ends i.e. within a length of 100 mm (3.937 in.) at each of the pipe extremities.

Dents that exceed the specified limits shall be considered defects and shall be treated in accordance with subclauses "b" or "c" of Clause C.3.

#### 9.10.6 Hard Spots

**The existing clause shall be deleted and replaced with the following:**

The hardness is limited to 27 HRC, 275 HV10 or 260 HBW, based upon individual indentations. Pipes that contain such defects shall be treated in accordance with subclauses "b" or "c" of Clause C.3.

**Note 1:** If specified by the purchaser, automatic online methods (e.g. eddy current, ...) should be used to detect hard spots as full-body inspection.

**Note 2:** Rolling marks (with a suitable frequency not more than once per each ten test unit) and surface imperfections (when occurred) should be checked for hardness with a portable hardness device; Destructive sampling may be requested by inspector with COMPANY'S approval.

### 9.10.7 Other Surface Imperfections

**Add to this clause the following:**

d) All sharp-bottom imperfections shall be considered as unacceptable defects, regardless of depth.

### 9.11 Dimensions, Mass and Tolerances

**9.11.3.2 The existing clause shall be deleted and replaced with the following:**

The tolerances for wall thickness shall be as given in Table 11.

**9.11.3.3 Add to this clause the followings:**

For 12 m random length pipes (in Table 12), minimum requirements shall be considered as follows:

Unless otherwise specified by the purchase, the average length of pipes in one order shall be not less than 11.6 m with a minimum of 95% of pipes between 11 and 12.2 m in length. No pipe shall be less than 10 m in length. No pipe shall be greater than 12.3 m in length.

**Note 1:** Unless otherwise specified by purchaser, 12 m random length pipes shall be ordered.

**Note 2:** Purchaser may be accept a specified quantity of pipes (generally equal and less than 0.5% of all pipes or others at COMPANY's discretion) with lengths outside the above limits (i.e minimum 10 m to maximum 12.3 m).

**Note 3:** For heavy wall seamless pipe, where supply of the pipe lengths stated above may not be possible, the purchaser and the manufacturer shall agree on an alternative pipe length.

**9.11.3.4 The existing clause shall be deleted and replaced with the following:**

The tolerances for straightness shall be as following:

- a) The total deviation from a straight line, over the entire pipe length, shall be  $\leq 0.15\%$  of the pipe length, as shown in Figure 1.
- b) The local deviation from a straight line at each end of 1 m (4 ft) portion at each pipe end shall be  $\leq 3.0$  mm (0.12 in) as shown in Figure 2.

**The existing Table 11 shall be deleted and replaced with the following:**

**Table 11 - Tolerances for wall thickness**

Wall Thickness (t) mm (in)	Tolerances <sup>a</sup> mm (in)
<b>SMLS Pipe <sup>b</sup></b>	
≤ 4.0 (0.157)	- 0.5 (0.020) to + 0.6 (0.024)
> 4.0 (0.157) to < 25.0 (0.984)	- 0.10 t to + 0.150 t
≥ 25.0 (0.984)	± 0.10 t
<b>Welded Pipe <sup>c,d</sup></b>	
≤ 5.0 (0.197)	± 0.5 (0.020)
> 5.0 (0.197) to < 10.0 (0.394)	± 0.10 t
> 10.0 (0.394) to < 15.0 (0.591)	- 1 (0.039) to + 0.10 t
≥ 15.0 (0.591)	- 1 (0.039) to + 1.5 (0.059)
<p><b>a.</b> If the purchase order specifies a minus tolerance for wall thickness smaller than the applicable value given in this table, the plus tolerance for wall thickness shall be increased by an amount sufficient to maintain the applicable tolerance range.</p> <p><b>b.</b> For pipe with <math>D \leq 355.6</math> mm (14.000 in.) and <math>t \leq 25.0</math> mm (0.984 in.), the wall thickness tolerance locally may exceed the plus tolerance for wall thickness by an additional <math>0.05t</math>, provided that the plus tolerance for mass (see 9.14) is not exceeded.</p> <p><b>c.</b> The plus tolerance for wall thickness does not apply to the weld area.</p> <p><b>d.</b> See 9.13.2 for additional restrictions.</p>	

**9.12 Finish of Pipe Ends**

**9.12.5.2 Add to this clause the following:**

- a) Beveling shall be carried out by machining only.
- b) Any repair by grinding on the bevel edge, further to machine beveling, shall require full re-beveling.

**9.12.5.6 Add this clause as the following:**

Unless otherwise specified by the purchaser, for wall thickness greater than 22 mm (7/8 in), the ends shall be beveled as shown in Figure.10 of this supplementary.

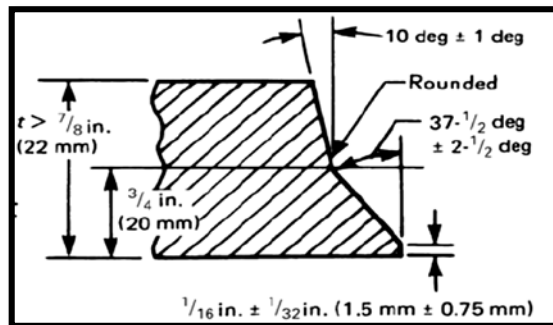

**Figure.10 - End preparation for pipe with a thickness over than 22 mm (7/8 in)**



## 9.13 Tolerances for the Weld Seam

### 9.13.1 Radial Offset of Strip/Plate Edges

**The existing Table 14 shall be deleted and replaced with the following:**

For SAW pipes, the maximum radial offset shall be 10% of the nominal wall thickness of the pipe, with a maximum of 1.5 mm.

### 9.13.2 Height of the Flash or Weld Bead/Reinforcement

**9.13.2.1 The existing clause and Table 15 shall be deleted and replaced with the following:**

For HFW pipe, the following shall apply:

- a) The external flash shall be trimmed essentially flush with the pipe surface, with no visually noticeable radial step.
- b) The internal flash shall not extend above the contour of the pipe by more than 0.3 mm (0.01 in.) + 0.05t [max 1.5 mm (0.06 in.)].
- c) The trimming shall not reduce the wall thickness to below the minimum permissible wall thickness (Table 11).
- d) The groove resulting from the trimming shall have a smooth transition to the base material without notches, with a maximum depth of 0.05t.

**9.13.2.2 The existing clause shall be deleted and replaced with the following:**

- a) Welds shall have a regular finish, merge smoothly into the base material and shall not extend beyond the original joint preparation by more than 8 mm (0.31 in.).  
During MPQT, a sample of the weld cross section macro shall be retained as a standard sample of acceptable cap profile at the MPS stage.
- b) For a distance of at least 100 mm (3.937 in.) from each pipe end, the inside weld bead shall be ground flush to -0.0 mm, +0.5 mm (0.02 in.) from the original contour of the pipe. For the remainder of the pipe, the inside weld bead shall not extend outside the applicable value given in Table 16 from adjacent pipe surface.
- c) For a distance of at least 150 mm (5.906 in.) from each pipe end, the outside weld bead shall be ground to a height -0.0 mm, +0.5 mm (0.02 in.) from the original contour of the pipe. For the remainder of the pipe, the outside weld bead shall not extend outside the applicable value given in Table 16 from adjacent pipe surface.
- d) When grinding seams, the transition between the base material to the pipe body shall be smooth without a visually noticeable step. The outside pipe diameter contour shall be maintained, avoiding grinding flat.
- e) Removal of pipe ends outside and inside weld beads using grinding wheels may be carried out after expansion, however shall be carried out before hydrostatic testing.
- f) Weld concavity is not permitted.

**The existing Table 16 shall be deleted and replaced with the following:**

**Table 16 - Permissible weld bead height for SAW pipes (except at pipe ends)**

Specified wall thickness <i>t</i> mm (in)	Weld bead height <sup>a</sup> mm (in) maximum			
	Internal bead		External bead	
	Min.	Max.	Min.	Max.
≤13,0 (0.512)	0.5 (0.02)	2.5 (0.098)	0.5 (0.02)	3 (0.118)
>13,0 (0.512)	0.5 (0.02)	3 (0.118)	0.5 (0.02)	3 (0.118)

a. At the option of the manufacturer and accepted by the purchaser, weld beads higher than permitted may be ground to acceptable heights.

**9.13.3 Misalignment of the Weld Beads of SAW Pipe**

**The existing clause shall be deleted and replaced with the following:**

Misalignment of the weld beads of SAW pipe [see Figure 4 d)] shall not be cause for rejection if it is within the limits specified in this section, and provided that complete penetration and complete fusion have been achieved as indicated by nondestructive examination and as demonstrated by macro examination.

The maximum misalignment of the weld beads shall not exceed 3 mm (0.1 in.) for pipe with specified wall thickness  $t \leq 20$  mm (0.8 in.) or 4 mm (0.16 in.) for pipe with specified wall thickness  $t > 20$  mm (0.8 in.).

For SAW pipes, the width of overlap, measured with a straight line perpendicular to the radial direction, shall be minimum  $\frac{1}{4} t$  or 5 mm (0.2 in.), whichever is less.

If specified by the purchaser, when the seam tracking system associated with the welding equipment is deemed insufficient to follow the pipe rotation, the weld penetration shall be visually checked at both pipe ends on every pipe, by chemical etching on the machined weld sections.

**9.13.4 Peaking**

**Add this clause as the following:**

Peaking of the pipe at the weld location shall not deviate by more than 1.5 mm (0.06 in.) from the theoretical form, when measured transverse to pipe axis using inspector accepted inside and outside templates (minimum 200 mm (7.87 in.) in length or 0.25D whichever is greater) / dial gauge.

**Note 1:** Peaking up to 2.5 mm (0.1 in.) may be allowed for SAWH pipes.

**9.13.5 Weld Toe Angle**

**Add this clause as the following:**

Unless otherwise specified by the purchaser, the weld toe angle for both OD and inner diameter ID welds shall not exceed 40°. It shall be measured from the tangent line of the base metal - weld metal crossing point to the curvature of the weld bead.

### 9.13.6 Welding Related Imperfections, Visual Examination

**Add this clause as the following:**

Arc burns, cracks, start/stop craters, poor restart and surface porosity are not permitted.

### 9.13.7 Systematic Imperfections

**Add this clause as the following:**

Systematic imperfections shall be reported. The source of the imperfections shall be investigated and corrected to ensure they do not lead to defects in subsequent production.

### 9.14 Tolerances for Mass

**9.14.1 The existing items "a", "b" and "c" shall be deleted and replaced with the following:**

For all pipes: +10.0%, -3.5%.

**9.14.3 The existing items "a", "b" shall be deleted and replaced with the following:**

For all grades: -1.75%.

### 9.15 Weldability of PSL 2 pipe

**Add to this clause the following:**

If specified by the purchaser, weldability tests shall be performed in accordance with Appendix 2.

When weldability tests are not specified, the manufacturer may be required to submit, to the satisfaction of the purchaser, comprehensive documentation to support the weldability of the finished pipe.

If specified by the purchaser, simulated post weld heat treatment (PWHT) shall be conducted during MPQT. Simulated PWHT should be 590 °C (1094 °F) - 610 °C (1130 °F) for one hour per inch of wall thickness.

### 9.16 Crack Tip Opening Displacement (CTOD) Test (for Fracture Toughness Evaluation)

**Add this clause as the following:**

If specified by the purchaser based on the service condition, CTOD test may be ordered by the purchaser and the minimum CTOD value (from a set of three specimens) taken from each of the pipe, weld and HAZ locations, at the 0 °C or minimum design temperature (whichever is lesser) shall be specified by the purchaser.

**Note 1:** Unless otherwise specified by the purchaser, the minimum CTOD value (from a set of three specimens) taken from each of the pipe, weld and HAZ locations, shall be 0.25 mm (0.0098 in), tested at the 0 °C or minimum design temperature (whichever is lesser) given in the order form.

### 9.17 Hardness Survey

**Add this clause as the following:**

Unless otherwise specified by the purchaser, finished pipes shall have a hardness level not exceeding 270 HV10 for base metal, weld, HAZ and cap area.

**9.18 Spring-back Ring Test for Residual Stress Evaluation**

**Add this clause as the following:**

Unless otherwise specified by the purchaser, Spring-back Ring test may be ordered by the purchaser for HFW and SAWH pipes.

Unless otherwise specified by the purchaser, the residual stress, as defined in Figure.11, shall not exceed ±10 % of the specified minimum yield strength of the pipe.

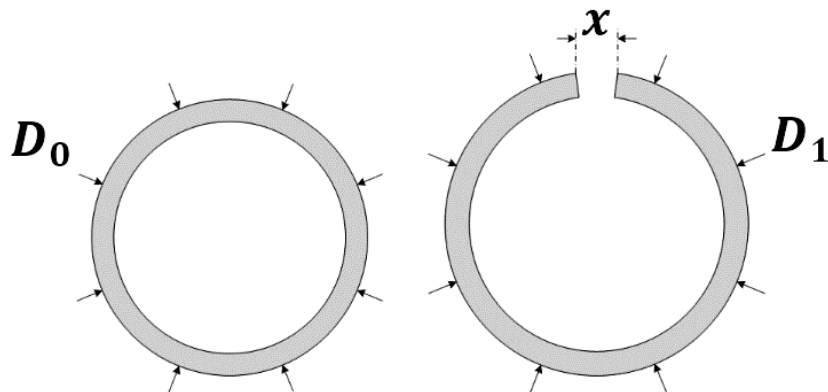

$$\sigma = \frac{Et}{1 - \mu^2} \left( \frac{1}{D_0} - \frac{1}{D_1} \right)$$

Measured using diameter differences [SOURCE: ASTM E1928]

$$\sigma = \frac{Et}{1 - \mu^2} \left( \frac{1}{D_0} - \frac{1}{\left[ \frac{x}{\pi} + D_0 \right]} \right)$$

Measured using the opening x

**Where:**

- σ is the residual stress;
- μ is Poisson's ratio;
- E is modulus of elasticity;
- D<sub>0</sub> is average outside diameter before splitting; and
- D<sub>1</sub> is average outside diameter after splitting.

**Figure.11 - Spring-back Ring Test**

### 9.19 Macrographic and Metallographic Examination

#### Add this clause as the following:

In addition to tests in Clause 8.3.3 of this standard and unless otherwise specified by the purchaser, the following requirements shall be considered. The manufacturer shall produce acceptance criteria for all following requirements, subject to acceptance by the purchaser, based on the results of the manufacturing procedure qualification (MPQT) tests and shall be applied in production.

The macro and metallographic examination shall be documented by macro and micrographs at sufficient magnification (e.g. X10, X100, and X400) and resolution to demonstrate that the base metal, and the weld metal quality meet the requirements of this specification.

The macro section on an SAW seam shall show the weld merging smoothly into the base material without weld defects, in accordance with ISO 5817 level C.

For SAW seam and HAZ areas, any untempered martensite found shall be brought to the attention of the purchaser for evaluation.

Additional requirements specific to HFW pipes are as follows:

- a) Metallographic examination of the HFW seam shall demonstrate that no detrimental oxides, inclusions and untempered martensite from the welding process are present.
- b) The manufacturer shall specify (as agreed with the purchaser) and record the following information and monitor during manufacturing:
  - Width and depth of heat treated zone; it shall be demonstrated that the entire weld heat affected zone has been heat treated over the full wall thickness and is free of defects. Furthermore, heat treatment procedure parameters such as temperature range, duration and frequency shall be specified.
  - Grain size (refer to ASTM E112) and microstructure of heat treated weld area; It should be ASTM No.7 and finer.
  - Welding parameters such as electric current, voltage, welding speed, heat input, welding roller force, welding frequency and welding temperature.
  - Maximum cold reducing and maximum seam misalignment.
  - Unless otherwise specified by the purchaser, during MPQT, the manufacturer shall approve that the heated surface layer throughout strip(coil) wall thickness will go out from weld seam during welding and resulted in external and internal upset height totally (i.e. external and internal extruded material) (see Figure.12).
  - During MPQT, deformation angle (i.e. the angle by which the material adjacent to the weld is displaced from the horizontal) or other means of assessment of deformation or squeeze pressure during welding, as agreed with the purchaser. Metallographic examination shall include an assessment of the level of deformation achieved during the welding operation, e.g. deformation angle (see Figure.13).

**Note 1:** Various techniques can be used for revealing and measuring metal flow distortion. Some methods that have proven successful individually or in combination include:

- saturated picric acid etchant in distilled water.
- specimens taken from a small pipe sample in which the seam has not been heat-treated.
- use of an optical comparator or profile projector.

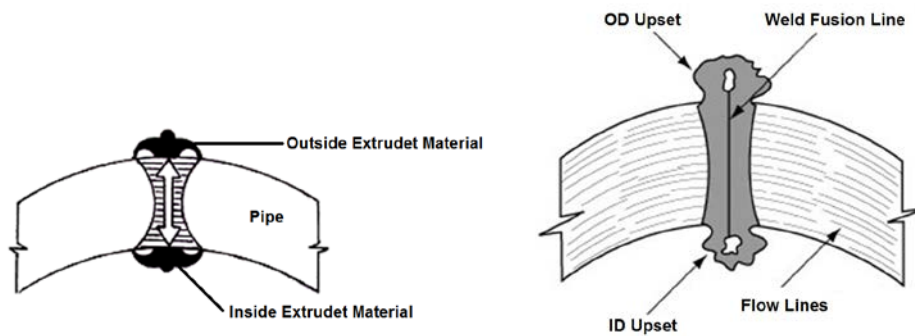

Figure 12 – External and internal upset

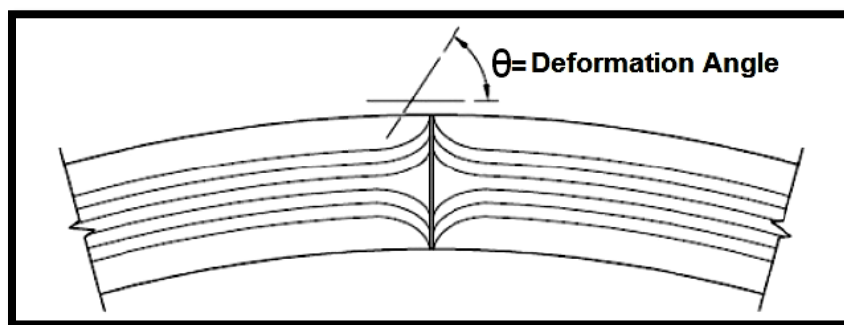

Figure 13 – Deformation angle and metal flow distortion

## 10. Inspection

### 10.1 Types of Inspection and Inspection Documents

#### 10.1.3 Inspection Documents for PSL 2 Pipe

##### 10.1.3.1 The existing clause shall be deleted and replaced with the following:

Unless otherwise specified by the purchaser:

The manufacturer shall issue an Inspection Certificate 3.1.B in accordance with ISO 10474:1991. If specified by the purchaser, an Inspection Certificate 3.1.A or 3.1.C in accordance with ISO 10474:1991 or an Inspection Certificate 3.2 in accordance with EN 10204:2004 shall be issued.

Final inspection reports shall be supplied as per the MPS and as a minimum shall be supplied in searchable electronic format e.g. PDF.

If specified by the purchaser, testing in which data curves are developed (e.g. tensile tests, compressive stress strain, CTOD, hydrostatic...) shall be supplied in native data formats that can be imported into a spreadsheet file.

The manufacturer shall prepare documents as MPQT, MPS, QCP and ITP before starting production; the documents shall cover at least the following:

- a) Flow diagram of all manufacturing stages associated with a summary key action in each stage shall be specified in MPQT and MPS.
- b) All related tests and evaluations associated with the relevant standard clause, acceptance criteria, frequency, action to nonconformity and type of report (e.g. table, curve...) shall be specified in QCP.
- c) Presence schedule of inspector throughout manufacturing stages and tests shall be specified in ITP.

## 10.2 Specific Inspection

### 10.2.1 Inspection Frequency

#### **10.2.1.2. The existing clause shall be deleted and replaced with the following:**

For PSL 2 pipe, the inspection frequency shall be as given in Table 18 as following. In case of test failure, the test specimen and the remaining part of tested pipes shall be stored by the manufacturer until Root Cause Analysis (RCA) is completed to the satisfaction of the purchaser.

**Note 1:** If specified by the purchaser based on the service condition, test frequency in Table 18 may be increased.

### 10.2.2 Samples and Test Pieces for Product Analysis

#### **Add to this clause the following:**

Samples shall be taken from finished pipe in the final condition i.e. after heat treatment, cold expansion, formed and welded.

Each specimen shall be prepared in a manner that does not intentionally enhance their mechanical properties.

### 10.2.3 Samples and Test Pieces for Mechanical Tests

#### 10.2.3.2 Test Pieces for the Tensile Test

#### **The existing footnote "c" of Table 20 shall be deleted and replaced with the following:**

Transverse test pieces shall be used. If transverse test pieces is not practical due to dimensional limitations, longitudinal test pieces should be used in agreement by purchaser.

**The existing Table 18 shall be deleted and replaced with the following:**

**Table 18 - Inspection frequency for PSL 2 pipe**

No.	Type of inspection	Type of pipe	Frequency of inspection (Production)	Frequency of inspection (First-day tests / MPQT) <sup>e</sup>
1	Heat analysis.	All pipes.	One analysis per heat of steel.	One analysis per heat of steel.
2	Product analysis.	All pipes.	One analyses per test unit.	Once for each selected test pipe.
3	Tensile testing of the pipe body	All pipes.	Once per test unit of pipes with the same cold-expansion ratio <sup>a,b</sup> .	Once for each selected test pipe with the same cold-expansion ratio <sup>a,b</sup> (Tensile test for pipe with D ≥ 219.1 mm (8.625 in.) shall be transvers and longitudinal direction and the results shall be within criteria for ordered pipe).
4	If specified by the purchaser, tensile testing at elevated temperature.	All pipes.	Once per test unit of pipes with the same cold-expansion ratio <sup>a,b</sup> .	Once for each selected test pipe with the same cold-expansion ratio <sup>a,b</sup> .
5	Tensile testing of the seam weld of welded pipe.	HFW, SAW.	Once per test unit of pipes with the same cold-expansion ratio <sup>a,b</sup> .	Once for each selected test pipe with the same cold-expansion ratio <sup>a,b</sup> .
6	Macrographic and metallographic testing of the pipe body.	All pipes.	Once per test unit of pipes with the same cold-expansion ratio <sup>a</sup> . Unless otherwise specified by the purchaser, banding and inclusion evaluations shall be performed once per each ten heat.	Once for each selected test pipe with the same cold-expansion ratio <sup>a</sup> .
7	Macrographic and metallographic testing of the seam weld of welded pipe.	SAW.	Once per test unit of pipes with the same cold-expansion ratio <sup>a</sup> and at least once per operating shift.	Once for each selected test pipe with the same cold-expansion ratio <sup>a</sup> .
8	Macrographic and metallographic testing of the seam weld of welded pipe.	HFW.	Once per test unit of pipes with the same cold-expansion ratio <sup>a</sup> and at least Once per operating shift.	Once for each selected test pipe with the same cold-expansion ratio <sup>a</sup> .
9	Hardness testing of the pipe body.	All pipes	Once per test unit of pipes with the same cold-expansion ratio <sup>a</sup> .	Once for each selected test pipe with the same cold-expansion ratio <sup>a</sup> .
10	Hardness testing of the seam weld of welded pipe.	SAW.	Once per test unit of pipes with the same cold-expansion ratio <sup>a</sup> .	Once for each selected test pipe with the same cold-expansion ratio <sup>a</sup> .
11	Hardness testing of the seam weld of welded pipe.	HFW.	Once per test unit of pipes with the same cold-expansion ratio <sup>a</sup> and at least Once per operating shift.	Once for each selected test pipe with the same cold-expansion ratio <sup>a</sup> .
12	Hardness testing of hard spots in cold-formed welded pipe	HFW, SAW.	Any hard spot.	Any hard spot for each selected test pipe.
13	Spring-back test.	HFW, SAWH.	Once per each slitted strip(coil) (See 8.3.2). If slitting is not performed, this test shall be done Once per each ten test unit.	Once for each selected test pipe with the same cold-expansion ratio <sup>a</sup> .
14	DWT testing of the pipe body of welded pipe with D ≥ 406.4 mm (16 in).	All pipes.	Once per test unit of pipes with the same cold-expansion ratio <sup>a</sup> .	Once for each selected test pipe with the same cold-expansion ratio <sup>a</sup> . Full transition curve plotted against temperature of 20, 0, -20, -40 and -60 °C.
15	Guided-bend testing of the seam weld of welded pipe.	SAW.	Once per test unit of not more than 50 lengths of pipes with the same cold-expansion ratio <sup>a,b</sup> .	Once for each selected test pipe with the same cold-expansion ratio <sup>a,b</sup> .
16	Flattening test of welded pipe.	HFW.	As per Figure 6.	As per Figure 6, for each selected test pipe.



**Table 18 – (continued)**

No.	Type of inspection	Type of pipe	Frequency of inspection (Production)	Frequency of inspection (First-day tests / MPQT) <sup>e</sup>
17	CVN impact testing of the pipe body.	All pipes.	Once per test unit of pipes with the same cold-expansion ratio <sup>a,b,c</sup> .	Once for each selected test pipe with the same cold-expansion ratio <sup>a,b</sup> . A full transition curve plotted against temperature of 20, 0, -20, -40, and -60°C.
18	CVN impact testing of the seam weld and HAZ of welded pipe.	SAW.	Once per test unit of pipes with the same cold-expansion ratio <sup>a,b,c</sup> .	Once for each selected test pipe with the same cold-expansion ratio <sup>a,b,c</sup> .
19	CVN impact testing of the seam weld of welded pipe.	HFW.	Once per test unit of pipes with the same cold-expansion ratio <sup>a,b,c</sup> and at least Once per operating shift.	Once for each selected test pipe with the same cold-expansion ratio <sup>a,b,c</sup> .
20	If specified by the purchaser, CTOD of weld metal, HAZ and base material.	All pipes.	Unless otherwise specified by the purchaser, once per each ten heat.	Once for each selected test pipe with the same cold-expansion ratio <sup>a</sup> .
21	Hydrostatic testing.	All pipes.	Each pipe.	Each selected test pipe.
22	Visual inspection.	All pipes.	Each pipe.	Each selected test pipe.
23	Pipe diameter	All pipes	Each pipe.	Each selected test pipe.
24	Out-of-roundness, Out-of-squariness and straightness.	All pipes	Each pipe.	Each selected test pipe.
25	Wall thickness measurement.	All pipes	Each pipe.	Each selected test pipe.
26	Other dimensional testing.	All pipes.	At least once per 4 hours operating shift plus. Furthermore, it may be random testing, with the details left to the discretion of the manufacturer.	Each selected test pipe.
27	Weighing of pipe.	All pipes.	Each pipe.	Each selected test pipe.
28	Length.	All pipes.	Each length of pipe.	Each selected test pipe.
29	Non-destructive inspection	All pipes	Each pipe in accordance with Annex E or Annex K as specified by the purchaser.	Each selected test pipe in accordance with Annex E or Annex K as specified by the purchaser.

**a.** The cold-expansion ratio (if applicable) is designated by the manufacturer, and is derived using the designated before-expansion outside diameter or circumference and the after-expansion outside diameter or circumference. An increase or decrease in the cold-expansion ratio of more than 0.002 requires the creation of a new test unit.

**b.** Pipe produced by each welding machine shall be tested at least once per week.

**c.** Other tests and requirements for MPQT shall be considered according to Annex B and everywhere throughout this standard.

**10.2.3.3 Test Pieces for the CVN Impact Test**

**The existing "NOTE" shall be deleted and replaced with the following:**

NOTE: Pipe body impact testing shall be carried out using the largest possible transverse specimens without or with tapered ends (due to dimensional limitations) as Table 22. Where the pipe dimensions are insufficient to extract transverse specimens, impact testing shall be carried out using the largest possible longitudinal specimens. The required energy for longitudinal specimens shall be at least 50% higher than required energy for transverse specimens considering ratio factor as Clause 9.8.1.1. For weld and HAZ impact tests, only transverse specimens shall be used.

**10.2.3.3.1 Seamless Pipes**

**Add this clause as the following:**

For test pieces taken from seamless pipes, the specimen's axis shall be aligned with the mid-thickness of the pipe.

During MPQT, for seamless line pipe with wall thickness greater than 20 mm (0.79 in.), Charpy impact testing shall be done on specimens taken from the ID and OD.

During MPQT, for seamless line pipe with wall thickness greater than 35 mm (1.38 in.), Charpy impact testing shall be done on specimens taken from ID, mid-wall and OD.

Coupons/specimens shall not be flattened.

**10.2.3.3.2 Welded Pipes**

**Add this clause as the following:**

During MPQT, the axis of the notch shall be taken as close as practicable to the weld metal, the fusion line (FL) that consists of 50 % weld metal and 50 % HAZ, and the fusion line + 2 mm (0.08 in.) (FL2). The specimen shall be taken as close as practicable to the OD surface of the pipe, i.e. within 2 mm (0.08 in.) of the outer surface of the pipe.

During MPQT, for SAW pipe with wall thickness equal to or greater than 25 mm (1 in.), additional testing [weld metal, fusion line and fusion line +2 mm (0.08 in.)] shall be done as close as practicable to the ID surface of the pipe, i.e. within 2 mm (0.08 in.) of the inner surface of the pipe.

During MPQT, for HFW during MPQT Charpy testing shall be sampled in positions 1, 2 and 3 as shown in Figure 14. In production, only positions 1 and 2 shall be sampled.

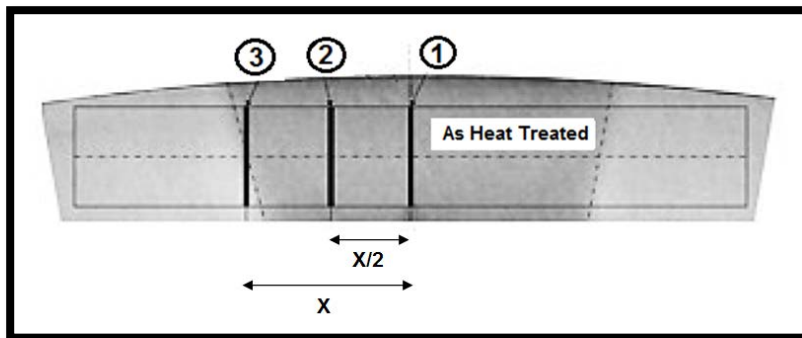

**Key**

- ① On the weld line ( $\pm 0.25$  mm (0.01 in.)).
- ② On the midway of heat treated area.
- ③ On the transition between base metal and heat-treated area after seam weld heat treatment.

**Figure 14 – CVN Testing of HFW Weld Seam**

**10.2.3.8 Test Pieces for CTOD Test**

**Add this clause as the following:**

Unless otherwise specified by the purchaser:

Test pieces for a CTOD test shall meet the requirements below:

- a) Test pieces shall be taken from the weld metal, the HAZ and the parent metal.
  - b) Test pieces shall be prepared in accordance with ISO 12135, ISO 15653 or BS 7448-1.
  - c) Test pieces shall be Bx2B through thickness notched specimens.
  - d) For weld metal testing, the notch axis shall be located on the weld center line.
  - e) For HAZ specimens, the notch axis shall be located so as to sample the fusion line.
  - f) The central 50 % portion of the specimen shall sample the HAZ.
  - g) The outer portions of the specimen shall sample weld metal.
  - h) Test pieces for base metal shall be taken at location 180° from the weld seam and have position YX, per Figure 15.
  - i) Test pieces for weld metal and HAZ area shall be taken from position NP, per Figure 15.
- The number of valid CTOD tests for each location shall be a minimum three.

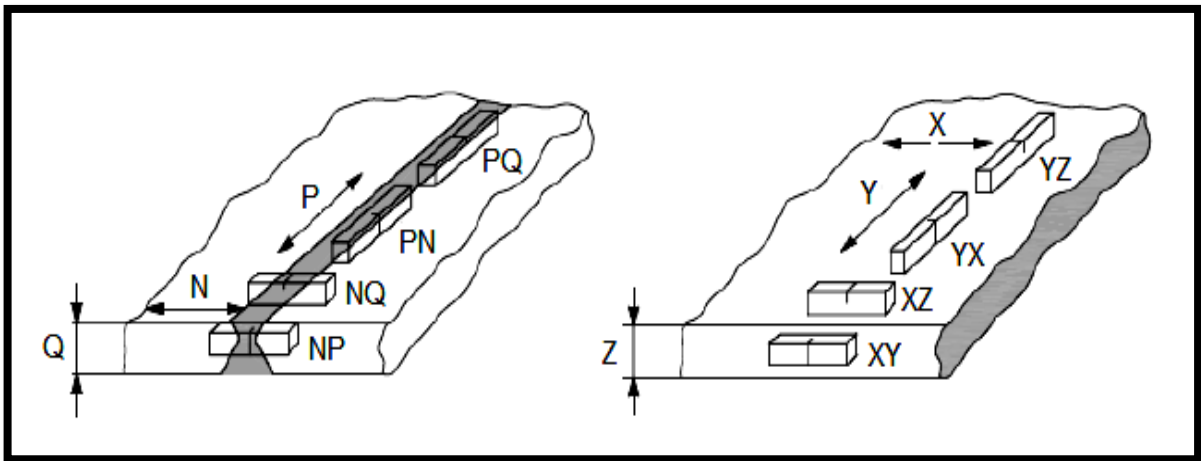

**Key**

- X parallel to rolling direction.
- Y transverse to rolling direction.
- N normal to weld direction.
- P parallel to weld direction.
- Z weld thickness direction.
- Q weld thickness direction.

**Figure 15 – CTOD Orientation**

**10.2.3.9 Test Piece for Spring-back Test**

**Add this clause as the following:**

Unless otherwise specified by the purchaser, the length of the sample piece of tube should be at least three times the outside diameter and a minimum 150 mm (5.90 in.) long, to avoid significant end effects.

---

**10.2.3.10 Test Pieces for Hardness, Macro and Metallographic Examination****Add this clause as the following:**

Sampling for hardness testing shall be as below:

- a) For seamless pipe, two test pieces, 180° apart shall be taken from finished pipe.
- b) For welded pipe, test pieces (three) shall be taken from the seam weld, and 90° and 180° from the seam weld.

The test pieces shall be prepared according to ISO 17639. The surface to be examined shall be perpendicular to the pipe axis.

**10.2.4 Test Methods****10.2.4.9 Spring-Back Test****Add this clause as the following:**

Unless otherwise specified by the purchaser, spring-back testing method shall be in accordance with ASTM E1928.

**10.2.4.10 Fracture Toughness Test****Add this clause as the following:**

Unless otherwise specified by the purchaser, CTOD testing shall be performed in accordance with ISO 12135, ISO 15653 or BS 7448-1.

**10.2.5 Macrographic and Metallographic Test****10.2.5.2 The existing clause shall be deleted and replaced with the following:**

Alternative methods are not acceptable.

**10.2.5.3 Add to this clause the following:**

For HFW pipe, metallographic examination of the weld seam shall be carried out at a magnification of at least X200.

Hardness testing shall be performed as per Figure H.1.

During MPQT, hardness testing shall be performed as per Figures 16, 17 and 18 as applicable and using the Vickers test shall be in accordance with ISO 6507-1 or ASTM E384 or ASTM E92. For base metal (i.e. at 90° and 180°), a minimum of 12 indentations shall be made for below ID and OD surfaces, and at mid-wall thickness, as shown in Figure 16. Unless otherwise specified by the purchaser, a minimum of 12 readings shall be taken at 5 mm intervals.

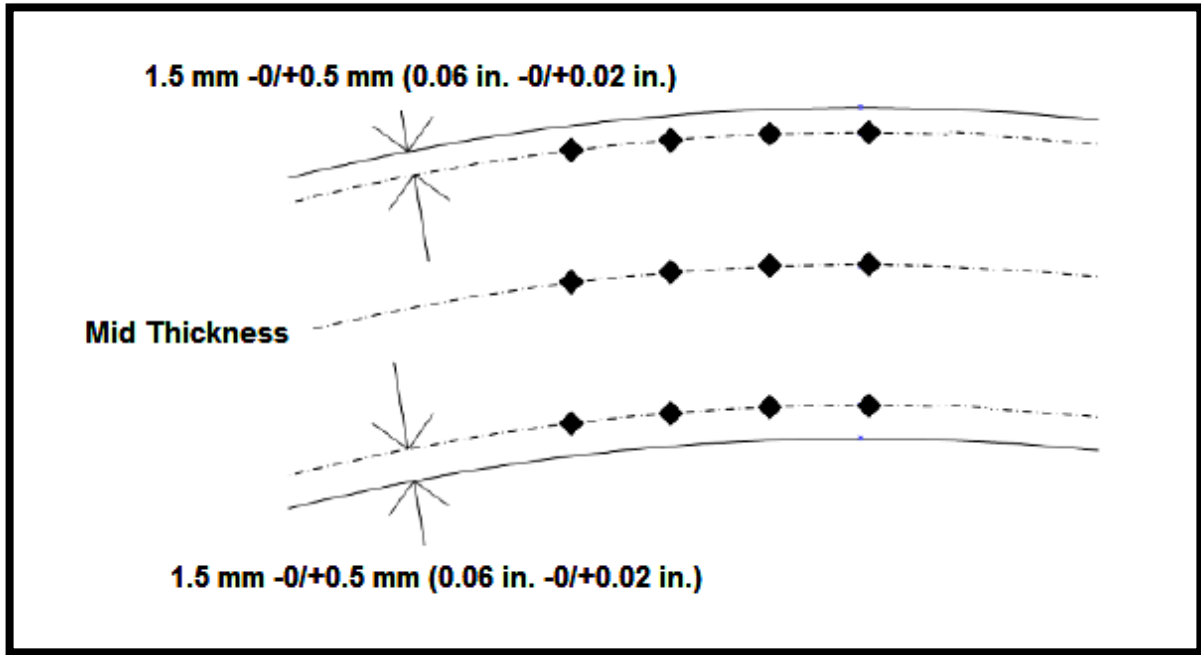
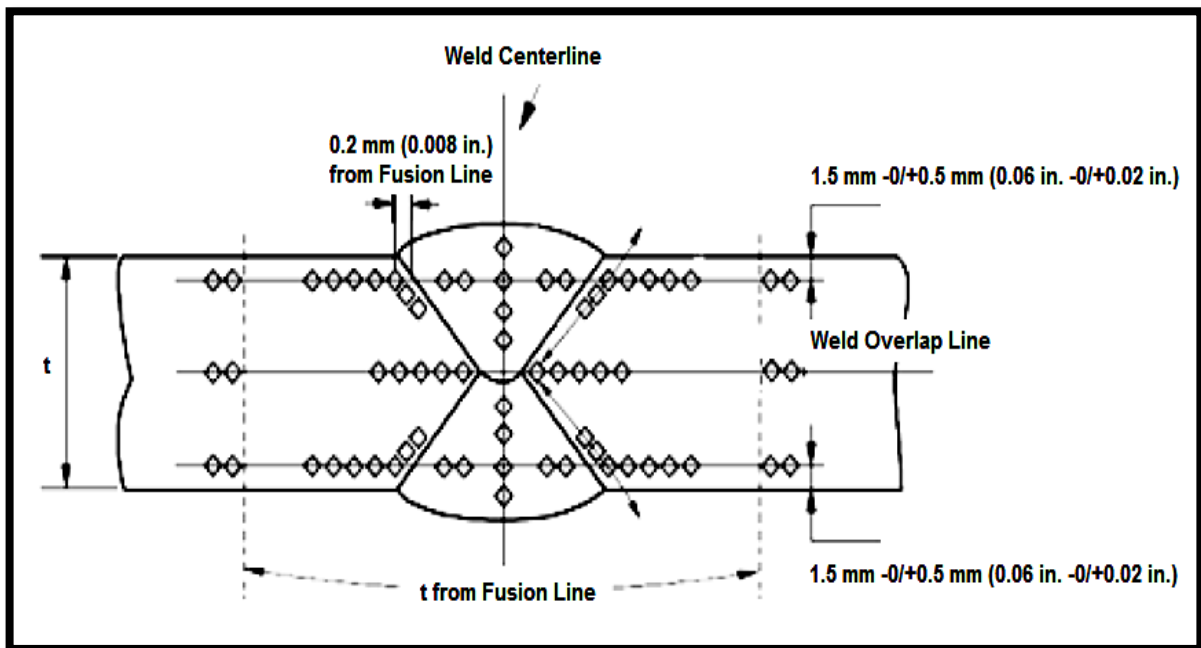

Figure 16 – Base Material (typical)



**Notes:**

1. Base material indents spacing: 2.0 mm +/- 0.1 mm (0.08 in. +/-0.004 in.).
2. HAZ indents spacing: 0.5 mm -0 / +0.1 mm (0.02 in. +/-0.004 in.).
3. Weld metal indents spacing: 1.0 mm +/- 0.1 mm (0.04 in. +/-0.004 in.).

Figure 17 – SAW Welds

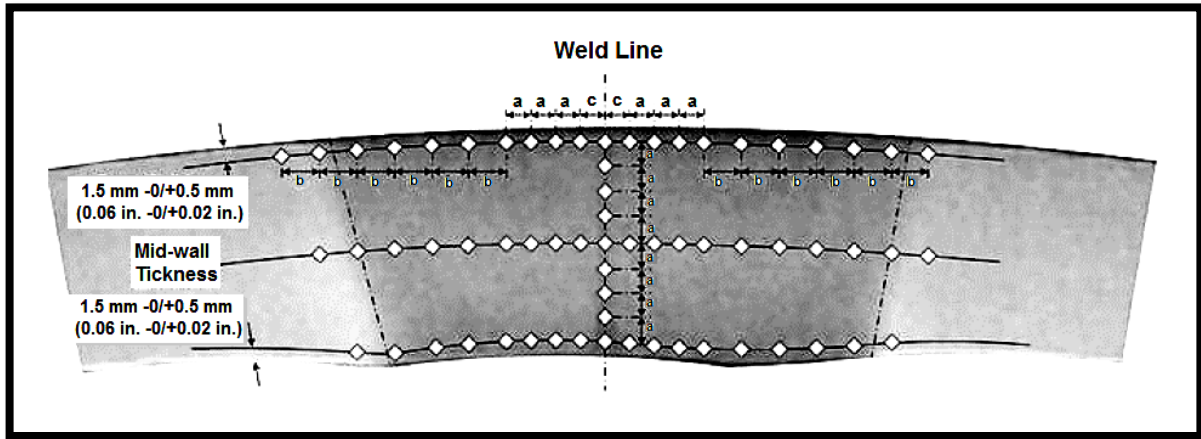

**Key**

- a = 1.0 +/- 0.1 mm (0.04 in. +/-0.004 in.).
- b = 2.0 +/- 0.1 mm (0.08 in. +/-0.004 in.).
- c = 5.0 +/- 0.1 mm (0.02 in. +/-0.004 in.).

**Figure 18 – HFW Welds**

**10.2.6 Hydrostatic Test**

**10.2.6.1 The existing clause shall be deleted and replaced with the following:**

Each length of pipe shall withstand a hydrostatic testing such that the hoop stress, calculated on the basis of the specified wall thickness and including stresses from end loading, is at least 95% of the specified minimum yield strength (SMYS).

The test pressure for all sizes and types of pipe shall be held for not less than 10 seconds without leakage.

The hydrostatic test shall be conducted after all manufacturing processes (including repairs and heat treatments) are completed; also, hydrostatic testing shall be performed after cold expansion (if applicable).

The water for testing should be clean and free from any suspended or dissolved substance that can be harmful to the line pipe material.

**Note 1:** For HFW pipes, if specified by the purchaser based on the severity of service condition, a hydrostatic testing such that the hoop stress, calculated on the basis of the specified wall thickness and including stresses from end loading, is at least 100% of the specified minimum yield strength (SMYS).

**10.2.6.2 Add to this clause the following:**

The test configuration shall permit bleeding of trapped air prior to pressurization of the pipe.

The equipment shall be capable of measuring a pressure variation of a minimum of 2 % of the applied pressure.

**Note 1:** Test pressure shall not be less than whatever calculated as clause 10.2.6.

Mill hydrostatic test pressure records shall show clearly the pipe number, date of test, applied test pressure and test duration for each pipe.

A chart of pressure records shall be reported for conformance check by the inspector.

**10.2.6.5 Table 26 shall be deleted.**

**10.2.6.7 This clause shall be deleted.**

### **10.2.7 Visual Inspection**

**10.2.7.1 The existing clause shall be deleted and replaced with the following:**

Each pipe (body and seam weld if applicable) shall be visually inspected according to ISO 17637, with an illuminance of at least 350 lx. Such inspection shall be over the entire external surface and shall cover as much of the internal surface as is practical. For pipe with  $D \geq 609.6$  mm (24 in.), the entire internal surface should be visually inspected.

### **10.2.8 Dimensional Testing**

**10.2.8.1 The last sentence of this clause shall be deleted and replaced with the following:**

For  $D \geq 508$  mm (20.00 in.), measurements made by circumferential tape shall govern in case of dispute.

**10.2.8.2 Add to this clause the following:**

A bar gauge, a caliper or a device that measures actual maximum and minimum diameters shall be used for measuring out-of-roundness of pipe ends. The absolute maximum and minimum OD shall be measured to determine the out-of-roundness.

**10.2.8.8 Add this clause as the following:**

Straightness measurements shall be taken using a taut string or wire from end to end along the pipe, measuring the greatest deviation. Other equivalent methods may be used, including optical and automatic systems. The length of each pipe shall be measured with tape or another automatic measuring device.

### **10.2.12 Retesting**

**Add to this clause as the following:**

Where one specimen fails to conform to the specified requirements, the manufacturer may elect to perform retesting in accordance with Clauses 10.2.12.1 to 10.2.12.8 as applicable.

If any test specimen fails due to some defect in the material, it may be substituted by another test specimen, with prior acceptance of the purchaser's representative. The nature of the defect shall be made clear and the inspector shall specify additional nondestructive testing to ensure that the defect is an isolated case.

## **11. Marking**

**11.1.1 Add to this clause the following:**

The quality of the paint employed for marking shall be perfectly readable for at least a year, for pipes exposed to outdoor weather conditions and marking shall be coated with a durable and legible lacquer to prevent corrosion.

## 11.2 Pipe Marking

### **11.2.1 The existing clause shall be deleted and replaced with the following:**

Unless otherwise specified by the purchaser:

Outside marking items: At least as following for all pipes:

- a) Name or trademark of the manufacturer.
- b) Related edition of "API Spec 5L", and "IPS-M-PI-190" shall be marked.
- c) API monogram certificate number & date (If requested by COMPANY).
- d) Specified outside diameter.
- e) Specified wall thickness.
- f) Pipe steel grade and Delivery condition (i.e. heat treatment type).
- g) Product specification level designation (PSL).
- h) Type of pipe.
- i) Sour service or Non-Sour service as applicable.
- j) Tested shall be marked for specified hydrostatic test pressure.
- k) Actual length of pipe.
- l) Actual weight of pipe.
- m) Heat number of pipe.
- n) Pipe No.
- o) Name of the purchaser.
- p) Order number.

Inside marking items: At least as following for all pipes with  $D \geq 16$  in:

- a) Name or trademark of the manufacturer.
- b) Pipe steel grade and Delivery condition (i.e. heat treatment type).
- c) Product specification level designation (PSL).
- d) Heat number of pipe.
- e) Pipe No.
- f) Order number.

### **11.2.3 The existing clause shall be deleted and replaced with the following:**

Unless otherwise specified by the purchaser:

- a) For pipe with  $D \leq 1.900$  in, the marking shall be on the outside surface at one end of each pipe.
- b) For pipe with  $1.900 < D < 16$  in, the marking shall be on the outside surface of the pipe, starting at



a point between 450 mm and 760 mm from one of the pipe ends.

- c) For pipe with  $D \geq 16$  in, the marking shall be on the outside and inside surface of the pipe, starting at a point at least 150 mm from one of the pipe ends.
- d) On HFW pipe, the manufacture shall apply a line of heat resistant white paint with 50 mm wide on the inside surface at each end of each pipe to mark the location of the weld line.

**Note 1:** For coated pipe, marking may be on the coating (not required outside surface of pipe).

**11.2.4 Add to this clause the following:**

Vibro-etching is not permitted.

**11.2.8 The existing clause shall be deleted and replaced with the following:**

Unless otherwise specified by the purchaser the manufacturer shall apply a ring of paint as following:

- 1- For pipe with  $D < 1.900$  in, apply a 50 mm wide paint strip fully circumferential on the external surface at both ends of each pipe.
- 2- For pipe with  $D \geq 1.900$  in, apply a 50 mm wide paint strip fully circumferential on the inside surface at both ends of each pipe.

The paint color shall be as given in Table 27 if the pipe grade is applicable; for all other grades, the paint color shall be as specified by the purchaser.

**The existing Table 27 shall be deleted and replaced with the following:**

**Table 27- Paint Color**

<b>Paint grade</b>	<b>Paint color</b>
L 245 or B	Silver
L 290 or X42	Brown
L 320 or X46	Black
L 360 or X52	Green
L 390 or X56	Blue
L 415 or X60	Red
L 450 or X65	White
L 485 or X70	Purple-violet
L 555 or X80	Yellow

## 14. Pipe Loading

### 14.1 General

**Add this clause as the following:**

- a) All pipes shall be fitted with bevel protectors.
- b) Pipe shall be bare and free of oil, grease, lacquer, antifreeze (from UT couplant) and other contaminants, such as chlorides, that adversely affect coating adhesion.
- c) All pipe shall be handled, loaded and shipped in accordance with API RP 5L1, API RP 5LT and API RP 5LW, as applicable.
- d) A procedure for handling, transport and storage detailing the proposed methods of handling, stacking during storage, method of preservation, and stacking and securing pipes for transportation and shipment shall be submitted to the purchaser for review and acceptance.

### 14.2 Shipping

**Add this clause as the following:**

- a) The manufacturer shall submit with the shipping procedures a written method to prevent salt contamination of the pipe at the receiving facility.
- b) For marine shipping, the ship's log shall be made available to the purchaser for review when the pipe is unloaded.
- c) At least eight weeks prior to shipment, the manufacturer shall submit loading instructions and diagrams for review and comment, for all pipe shipped by truck or vessel.
- d) When the manufacturer is responsible for handling or shipping, the purchaser's review and comment of these loading instructions shall not relieve the manufacturer of responsibility for any damage during shipment. If in-transit fatigue cracks are detected after shipment, the purchaser shall reserve the right to reject the entire shipment until an absence of fatigue cracking is proven on the entire shipment, by a specified NDT method by the purchaser.

### 14.3 Handling

**Add this clause as the following:**

Non-metallic strip shall be used for handling of pipe.

**Note 1:** Handling devices that contain copper or copper alloys shall not be used.

**Note 2:** Unless hookable end caps are fitted, hooks shall not be used for.

### 14.4 Storage

**Add this clause as the following:**

- a) No over stowage or deck loads shall be permitted. The storage of pipe shall be elevated off the ground, sloped and not in contact with other pipe. Pipe shall not be nested one diameter inside another.
- b) All handling, loading and unloading shall be carried out in such a way as to avoid magnetization, mechanical damage and prevent stresses which result in dents or out-of-roundness.
- c) All dimensional tolerances and pipe surface conditions specified within this specification and API 5L shall apply to the pipe condition as received by the purchaser at the shipping destination.

The manufacturer shall be responsible for any permanent deformations subsequent to mill acceptance and resulting from loading, storing, stacking, transportation or shipping, provided that these operations are within the scope of the manufacturer.

**Annex B  
(Normative)**

**Manufacturing Procedure Qualification for PSL 2 Pipe**

**B.1 Introduction**

**The existing clause shall be deleted and replaced with the following:**

1. Manufacturing procedure qualification shall be required for all PSL2 pipe unless otherwise specified by the purchaser.
2. Qualification shall be carried out on each combination of diameter and wall thickness supplied unless otherwise specified by the purchaser.
3. The qualified manufacturing procedure shall form the basis for pipe acceptance.
4. Deviation from the qualified manufacturing procedure shall require full requalification in accordance with the requirements of (B.5). The purchaser shall reserve the right to require requalification in the case of a change in the procedure specification.
5. The Manufacturer shall inform the purchaser within 48 hours of any intentional or unintentional manufacturing deviations from the agreed procedures, dimensional tolerances, or composition. The Manufacturer shall communicate these changes even if the finished pipes meet the requirements of this standard or any other agreed document.
6. The manufacturing procedure shall be qualified by selecting at random three of the completely finished pipes of the first day's production in each size (each diameter and each wall thickness), grade and steel source (first shift production) at the COMPANY discretion. The MPQT pipes shall be selected by the inspector.
7. Unless otherwise specified by the purchaser, in the first-day production, at least two heats shall be represented by the test pipes.
8. All related tests for ordered pipes based on this standard or any other agreed document shall be performed on each test pipe.
9. For HFW pipe, the test pipes shall include the pipes made from each end of the first coil of strip.
10. Unless otherwise specified by the purchaser, for orders less than 50 tons, first day production tests are not required and may use of data from a previous order with similar pipe grade, size, and manufacturing method.
11. With purchaser approval, part or all of the manufacturing procedure qualification may be carried out prior to first day production, but shall use plate or strip(coil) ordered for production and the same welding machines and procedure and NDT equipment as proposed in production.

**B.2 Additional Information to be applied by the Purchaser**

**The existing clause shall be deleted and replaced with the following:**

- a) The manufacturer shall submit a comprehensive manufacturing procedure specification (at least items as per B.3) and an inspection and test plan (at least items as per B.4), for the purchaser's acceptance prior to the start of production.
- b) A manufacturing procedure qualification test in accordance with at least items B.5 shall be carried out.

**B.3 Characteristics of the Manufacturing Procedure Specification****The existing first paragraph shall be deleted and replaced with the following:**

The MPS shall be prepared for each mill to cover each type of pipe, delivery condition, nominal pipe diameter, grade and specified wall thickness.

The required information may be included within the MPS or provided as standalone document, at the manufacturer's discretion.

Before production commences, the manufacturer shall supply the purchaser with summary information or identification of the control documents as applicable, on the main characteristics of the manufacturing procedure.

This shall include a plan and process flow description/diagram and at least the following information:

**a) Steelmaking and casting - for all pipe:****The existing items a) 2,3,5,7,8 shall be deleted and replaced with the following:**

- 2) Equipment and process description including steelmaking method, heat size, deoxidation practice, control of slag physicochemical properties and slag removal, secondary/ladle refining, degassing and stirring practice, inclusion shape control practice, and casting method.
- 3) Control of chemical composition, based on target chemical composition (to be agreed prior to start up).
- 5) Hydrogen control practice.
- 7) Product reprocessing/retesting/release controls for nonconformances to the manufacturer's documented practices and this standard.
- 8) Steelmaking and casting methods used to mitigate segregation and inclusions during the continuous casting process. The documentation shall include a description of the processes, quality control steps and tests to assure adequate quality of the final pipe. Control of steel cleanliness and centerline segregation, including the acceptance criteria.

**Add items a) 9,10,11 as the following:**

- 9) Control of steel scrap.
- 10) Billets and slabs visual inspection and associated acceptance criteria.
- 11) Quality plan detailing all inspection points and tests performed in accordance with ISO 10005 or any agreed standard by the purchaser.

**b) Pipe manufacturing - for all pipe:****The existing items b) 1,3,4,8,10,11 shall be deleted and replaced with the following:**

- 1) Name/location of manufacturing facility; Strip(coil)/plate manufacturing method including details of rolling conditions, accelerated cooling conditions (if applied) and heat treatment method (N or Q) if applicable.
- 3) Hydrostatic testing practices including calibration of equipment and records of the test.

- 
- 4) Non-destructive inspection methods and practices including calibration practice and records of the test.
  - 8) Pipe marking process and details (including freehand marking limitation, lettering height, distance from pipe ends, painted colored band).
  - 10) Product reprocessing/retesting/release controls for nonconformances to the manufacturer's documented practices and this standard.
  - 11) Pipe storage, handling (including pipe end protection), loading and shipping practices.

**Add items b) 12,13,14,15,16,17,18,19,20,21,22,23 as the following:**

- 12) Method for cold expansion/reduction/sizing/finishing, target and maximum sizing ratio.
- 13) Control of intermediate heat treatment process if any (e.g. quenching or normalizing).
- 14) Control of final heat treatment process.
- 15) Heat treatment procedure including a sketch of the heat treatment facilities layout, showing furnaces and quenching bath relative to each other.
- 16) Type, identification of furnaces and sketch of furnaces showing, overall dimensions, working zone and location of heat elements.
- 17) Location and identification of thermal sensors in the furnace. Sensors for temperature regulation and sensors for temperature control shall be clearly distinguished. Method of heating and fuel (if applicable).
- 18) Calibration frequency of the thermocouples.
- 19) Maximum operating temperature of furnaces.
- 20) Loading temperature, heating and cooling rate, soaking temperature set-up and soaking time with associated tolerances and maximum transfer time.
- 21) For continuous and semi-continuous furnaces: travel speed and minimum soaking time as function of size (e.g. thickness, diameter, cross section, etc.) for products to be heat-treated and other relevant parameters.
- 22) Arrangement of pipes inside the furnaces including minimum distance between pipes, number of pipe layers in the furnace and location of the weld seam.
- 23) Identification and control of individual pipes throughout the heat treatment cycle.
- 24) For sour service pipe, the HIC and SSC test procedures shall include full details of the exposure test method and the procedure used for metallographic preparation of the exposed test pieces.

**c) Hot rolling - for welded pipe:****The existing item c) 2 shall be deleted and replaced with the following:**

- 2) Equipment and process description including slab reheating practices, minimum temperature and soaking time at slab reheating stage, rolling schedule and cooling practices.

**Add item c) 11 as the following:**

- 11) Plate cutting practice (including plate/ strip (coil) slitting).

**e) Pipe manufacture - for welded pipe:****Add to items 3 and 4 of this clause, the following:**

- 3) For HFW pipe, the seam welding procedure shall include at least details of the following:

- III. Methods to be used for heating strip(coil) edges and for the control and monitoring of power input in relation to the temperature of the pipe surface and the speed of the pipe.
- IV. Frequency (in kHz) of the welding power supply.
- V. Welding speed.
- VI. Welding Temperature (or Principal approved alternative method of monitoring weld quality).
- VII. Welding power.
- VIII. Compressive force or displacement used in welding.
- IX. Temperature of in-line normalizing or normalizing and tempering (if applied).
- X. Details of any protective atmosphere used for welding.
- XI. Methods used to accomplish and control the upset welding of the heated pipe edges.
- XII. Methods used for trimming of the weld bead.

- 4) For SAW pipe, the seam welding procedure shall include at least details of the following:

- V. Brand name, classification, size and grade of filler metal and flux.
- VI. Speed of welding.
- VII. Number of electrodes and polarity for each electrode.
- VIII. Stick out for each wire.
- IX. Welding current for each wire.
- X. Welding voltage for each wire.

**Add items e) 5,6 as the following:**

- 5) Preliminary welding procedure specification (PWPS) or previously qualified WPS (if available) including all essential variables from Table B.1 and Table B.2, unless otherwise specified by the purchaser.

**Note 1:** Other criteria for change essential variables in Table B.1 and Table B.2, may be specified by the purchaser.

- 6) Welding equipment, including weld tracking system.

**f) Pipe manufacture - for SMLS pipe:****Add items f) 3, 4, 5 as the following:**

- 3) Equipment and process description including billet reheating practices, minimum temperature and soaking time at billet reheating stage, tube manufacturing stage and finishing stage.
- 4) Control of process parameters for reheating, tube manufacturing and finishing stage.
- 5) End cropping practices.

**B.4 Characteristics of the Inspection and Test Plan****Add to this clause the following:**

- j) Quality plan detailing all inspection points and tests performed in accordance with ISO 10005 or any agreed standard by the purchaser.

**B5. Manufacturing Procedure Qualification Tests (MPQT)****B.5.0 Add this clause as the following:**

The MPS shall be validated through MPQT as described herein.

If one or more tests in the MPQT fail, the MPS shall be reviewed and modified accordingly, and a complete re-qualification performed. Retesting may be allowed subject to agreement by the purchaser. In the specific case of SAW failed fusion line CVN tests (with reference to local brittle zone), retesting of a further two sets removed from the failed MPQT pipe (at the same position relative to wall thickness) is permitted, prior to declaring the MPQT as having failed.

In cases where the qualification test results do not comply with the requirements of this specification, the pipe tested, as well as all preceding pipes, shall be rejected.

**B.5.1 The existing clause shall be deleted and replaced with the following:**

For qualification of the manufacturing procedure, the inspections and tests specified in Clause 8.3.3, Table 18, selected annexes and appendices (in accordance with purchase order) and the additional destructive tests specified in Clause B.5.2 shall be carried out.

**B.5.2 The existing clause shall be deleted and replaced with the following:**

If it is not specified by this standard, the frequency and amount of qualification testing shall be indicated by the purchaser, although requalification testing shall be approved by the purchaser.

The MPQT (i.e. first day production tests) shall be repeated after any change in the manufacturing procedure or interruption to the program.

The Manufacturer shall submit to the COMPANY a report giving the results of all related tests together with macrographs of the weld cross section and micrographs confirming the microstructure of the welded and seamless pipe.



### B.5.2.1 Macrographic, Micrographic and Segregation Analysis on Slabs (for Coil or Plate)

#### Add this clause as the following:

Unless specified by the purchaser:

The first, middle and last slab from the first heat shall be subject to macrographic, micrographic and segregation analysis. The analysis procedure shall be subject to agreement with the purchaser:

- a) Macrographic methods may be by macroetch (hot acid etch test) or magnetic particle testing.
- b) Micrographic methods shall be by optical microscope on the polished sample. A procedure shall be submitted for the purchaser's review and acceptance.
- c) Segregation analysis shall be carried out by cross-section chemical analysis at the surface of the slab,  $\frac{1}{4}$  slab thickness and  $\frac{1}{2}$  slab thicknesses (see Figure B.1). The chemical composition shall be within the variation of target chemical composition.

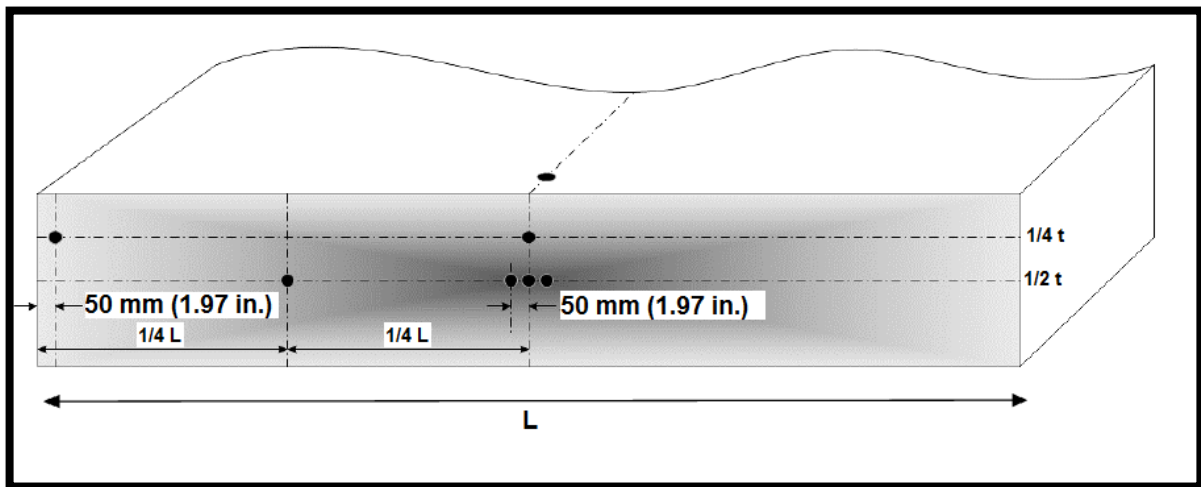

Figure B.1 – Slab Macrographic, Micrographic Analysis Sampling

### B.5.2.2 Charpy Impact Tests

#### Add this clause as the following:

A ductile brittle transition temperature (DBTT) curve, (at least in terms of energy and shear area) shall be developed from a Charpy impact test at least against temperatures of 20, 0, -20, -40, and -60°C at the following location:

- a) Seamless: DBTT shall be performed within the pipe body.
- b) HFW: DBTT shall be performed within the parent material and along the weld centerline within 0.25 mm (0.01 in.) from the fusion line.
- c) SAW: DBTT shall be performed within the parent material at 90° from the weld seam, along the weld centerline, on the fusion line and fusion line +2mm.

**Note 1:** If specified by the purchaser, the temperature range for testing may be extended when necessary to get sufficient data for representing fully a transition curve showing the transition area.

**Note 2:** The tests at temperatures below the target test temperature will be for information only.

**Note 3:** If specified by the purchaser, the transition curve shall be generated for both finished pipe and in the aged condition (see B.5.2.5).

### B.5.2.3 Tensile Tests

**Add this clause as the following:**

Parent material tensile test and all weld metal tensile tests (at ambient and elevated temperature if specified by the purchaser) shall be conducted to record the full stress-strain curve up to maximum load.

Two round bar all-weld tensile tests (one from inside and one from outside the weld bead; if it is not practical due to dimensional limitation, two back-to-back samples.) shall be performed.

The yield strength and tensile strength shall meet the requirements of the pipe base material. Elongation shall be as specified in ISO 2566-1 (should not less than 18 %). Reduction of area,  $R_{t0.5}/R_m$  ratio and uniform elongation shall be reported for information only.

**Note 1:** Unless otherwise specified by the purchaser, for determination of the elongation value, the "Oliver" formula, as specified in ISO 2566-1 may be used.

**Note 2:** If specified by the purchaser, data shall be supplied in native data formats that can be imported into a spreadsheet file.

**Note 3:** If specified by the purchaser, elevated temperature tensile tests shall be made in the longitudinal direction for all pipe sizes and the transverse direction for pipes with an outside diameter greater than 219.1 mm (8.63 in.). See Table 20. Acceptance criteria shall be specified by the purchaser.

### B.5.2.4 Macrographic, Metallographic and Hardness Tests on Pipes

**Add this clause as the following:**

Tests shall be performed at both ends of the MPQT pipes for up to three cross-sections at 0° (weld seam), 90° and 180° to be sampled for micrography and hardness.

They shall be polished and etched to show the metallurgical microstructure.

Photographs of the microstructure shall be supplied at three locations minimum, i.e. at below the ID and OD surfaces, and at mid-thickness.

The inclusion rating shall be performed in accordance with ASTM E45 (Method d) and the acceptance criteria shall comply with related requirements for ordered pipes.

**Note 1:** The base metal shall be examined for a banded structure in terms of "carbon / carbides segregation" and "ferrite or pearlite/martensite, etc". The acceptance criteria shall comply with related requirements for ordered pipes.

### B.5.2.5 Strain- Ageing Tests

**Add this clause as the following:**

Unless otherwise specified by the purchaser, Charpy, tensile and hardness testing shall also be performed in the aged condition if cold forming during manufacturing of C-Mn steel exceeds 5 % strain after heat treatment. The cold forming shall take into account all operations on the steel, including but not limited to, levelling of plate, pipe forming and expansion. The tests shall be performed on the actual pipe without any straightening or additional deformation according to a procedure with COMPANY's approval.

Unless otherwise specified by the purchaser, ageing shall be done by heating the specimen to a temperature of 250 °C (492 °F) with one hour soaking time.

**Note 1:** In most cases cold forming strain is less than 5 %. In exceptional cases where the D/t ratio is below 20, the requirement above applies only where no heat treatment is performed after final forming.

**B.5.2.6 Non-destructive Testing****Add this clause as the following:**

The following tests shall be carried out at least for one pipe of selected test pipes in accordance with Annex E or K (which one is related to ordered pipe). Cracks are unacceptable and their causes shall be investigated.

- a) The weld seams of SAW pipes shall be radiographically examined throughout their full length.
- b) The weld seams of all welded pipes shall be examined by means of an automatic ultrasonic scanning device.
- c) The weld seams of all welded pipes greater than or equal to DN 600 (NPS 24) shall be subjected to liquid penetrant or magnetic particle testing, throughout their full length both inside and outside, to check for longitudinal and transverse surface defects in the weld material.
- d) For pipe less than DN 600 (NPS 24), the full length of the weld seam outside surface, plus the equivalent length of one pipe diameter each end of the internal surface, shall be examined.
- e) Seamless pipe shall also be subjected to PT or MT over the entire outside pipe body.

**Note 1:** PT shall be in accordance with ASTM E165.

**B.5.2.7 Surface Condition Test****Add this clause as the following:**

Rolling marks and surface imperfections shall be checked for hardness with a portable hardness device and destructive sampling to compare the results. The results shall comply with related requirements for ordered pipes.

For seamless pipes, if specified by the purchaser, a surface condition test shall be carried out according to the following:

- a) In the absence of historic data, seamless pipe shall undergo blast cleaning and examination of three pipes during the manufacturing procedure qualification.
- b) The pipes shall be selected at random and heated to a minimum of 70 °C (160 °F).
- c) The outside surface of the pipe shall be blast cleaned to a surface finish of SA2½ and the pipe then re-heated to 250 °C (482 °F).
- d) Each pipe shall be examined visually over its entire surface for imperfections that could interfere with the FBE coating process.
- e) If a seamless pipe is rejected, the remaining pipes from the test unit and one pipe from each subsequent test unit shall be blast cleaned and examined.

**B.5.2.8 HIC and SSC Tests****Add this clause as the following:**

For pipe under sour services, HIC and SSC tests shall be performed as specified in Annex H.

**B.5.3 Add to this clause the following:**

**Note 1:** Unless otherwise specified by the purchaser, reference is made to Tables B.1 and B.2 for changes in essential variables that require new qualification.

**B.5.4 Add to this clause the following:**

Weldability test requirements shall be in accordance with 9.15.

Subject to the purchaser's acceptance, weldability tests may be undertaken separately to the MPQT.

**B.5.6 Add to this clause the following:**

Unless otherwise specified by the purchaser, any change to the essential variables listed in B.5.7 shall require a new MPQT.

**B.5.7 Welding Essential Variables****Add this clause as the following:**

If requested by the purchaser, a preliminary welding procedure shall be submitted and the following should be considered:

- a) Qualification of the welding procedure specification shall be carried out for each production before commencing the fabrication. Prequalified procedures may be accepted at the purchaser's discretion.
- b) The WPS and supporting procedure qualification record (PQR) shall be submitted to the purchaser for acceptance.
- c) During production, changes of any welding parameters defined as essential variables, outside the ranges specified in the WPS, will require requalification of the WPS. If other manufacturing essential parameters remain unchanged, requalification shall be limited to the WPS.
- d) The manufacturer shall provide details, subject to the purchaser's acceptance, of how the parameters detailed in B.5.7 are to be monitored and recorded.
- e) For HFW, the mill shall operate a welding system where the control parameters are used to adjust the welding process automatically. The system shall monitor, as a minimum, the voltage, current, welding power, travel speed, weld fusion point temperature (if available), frequency and squeeze roll pressure or load. These parameters shall be recorded at least every 10 milliseconds or as specified by the purchaser.
- f) As a minimum, all information required in ASME IX WPS format shall be listed.
- g) Welding records shall be available for review by the inspector during production and until the order is shipped.

**Table B.1 – Welding Essential Variable for SAW Pipes**

Essential Variables	Changes that require new qualification	
	GMAW	SAW
1) Base metal	A change in API 5L steel grade.	
	A change in CE <sub>PCM</sub> greater than 0.02 as an essential variable.	
	A change in CE <sub>IW</sub> greater than 0.03 as an essential variable.	
	A change in pipe delivery condition.	
	A change in specified wall thickness by more than -10% / +5%	
2) Bevel shape, angle	A change in bevel shape / groove type.	
	A change in root face by more than -1.5 mm / +1.5 mm (±0.06 in)	
	A change in root gap by more than -1.0 mm / +1.0 mm (±0.04 in)	
	A change in angle by more than -5° / +5°	
3) Filler metal	A change in number of wire.	
	A change in nominal wire diameter.	
	Any change in brand name.	
	A change in wire classification.	A change from one flux-wire classification to any other flux-wire classification.
	A change in wire manufacturer.	A change in flux or wire manufacturer.
4) Position of welding point (for SAWH pipe)	A change in location and distance between strip(coil)-pipe meeting point to ID welding point.	A change in location and distance between strip(coil)-pipe meeting point to ID welding point.
		A change in location for OD welding.
5) Preheat / interpass temperature	Methods to be used for heating strip(coil) edges.	
	Decrease in qualified minimum preheating and/or interpass temperature.	
	Increase of qualified maximum preheating and/or interpass temperature by > 50 °C (122 F).	
6) Equipment	A change in make, type and model of welding equipment.	
7) Electrical characteristics	A change in welding position, type of current and polarity.	
	A change in ±10 % in voltage, amperage, and wire feed speed for each wire.	
	A change in ±10 % in travel speed.	
	A change in ±7 % in welding heat input.	
	A change from Constant Voltage to Constant Current output.	A change of > 5mm (0.2 in.) in longitudinal or lateral spacing of the arcs.
	A change in the mode of transfer.	
8) Weld pass	A change in number of weld passes.	
9) Shielding gas	A change in gas composition.	
	Decrease in gas flow rate.	
	Increase in gas flow rate by more than 10%.	
10) Postweld heat treatment	Addition or deletion of PWHT.	
	A change in the PWHT temperature by more than ±10 °C (50 F).	
	A change of ≥ 10 % in soaking time.	

**Table B.2 – Welding Essential Variables for HFW Pipes**

Essential Variables	Changes that require new qualification
<b>1) Base metal</b>	A change in API 5L steel grade.
	A change in CE <sub>PCM</sub> greater than 0.02 as an essential variable.
	A change in CE <sub>IIV</sub> greater than 0.03 as an essential variable.
	A change in pipe delivery condition.
	A change in nominal wall thickness.
	A change in nominal pipe diameter.
	A change in the source of strip (coil).
<b>2) Transfer of welding current and the use of impeder</b>	A change in welding current transfer mechanism (either by induction strip (coil) or contact tips).
	A change in dimension of induction strip (coil) /contact tip, material, coolant type and the contact tip force.
	A change in the use, dimension, material and location of impeder.
<b>3) Equipment</b>	A change in make, type and model of welding equipment.
	Methods to be used for heating strip(coil) edges.
	Method to control and monitor power input in relation to the temperature of the pipe surface and the speed of the pipe.
<b>4) Induction strip (coil) configuration (HFW only)</b>	Any change.
<b>5) Impeder configuration (HFW only)</b>	Any change.
<b>6) Electrical characteristics</b>	A change of ±5 % in qualified frequency (frequency shall be ≥ 150KHz).
	A change of ±5 % in welding heat coefficient, $Q = (\text{amps} \times \text{volts}) / (\text{travel speed} \times \text{thickness})$ .
<b>7) Roll pressure on welding /squeezing point, squeeze-out and metal flow angle</b>	A change in roll pressure location.
	A change of > 5 % in roll pressure.
	Decrease in minimum qualified squeeze-out [squeeze-out should be > 4mm (0.16in.)].
	The metal flow angle should be within the range 45° - 60°.
<b>8) Shielding gas and coverage area</b>	A change in gas composition.
	Decrease in gas flow rate.
	Decrease in coverage area (as minimum beveled areas after induction strip (coil) /contact tip shall be protected).
<b>9) Weld seam heat treatment and cooling system</b>	A change of > 5 % in qualified frequency.
	Decrease in soaking time.
	Decrease in qualified exit temperature by >10 °C (50 F).
	A change in cooling system

**Annex C  
(Normative)**

**Treatment of Surface Imperfections and Defects**

**C.2.2 Add to this clause the following:**

All ground areas shall be smoothly contoured at a minimum 3 to 1 slope and the acceptable grinding processes are listed in Table C.1.

**Table C.1 – Acceptable Grinding Processes**

Manufacturing Stage	SMLS Pipe	Welding Pipe <sup>b</sup>
Before hydrostatic pressure	A Grinding wheel or flap wheel	-
After hydrostatic pressure	Only flap wheels (cosmetic grinding <sup>a</sup> )	-
Before expansion	-	A Grinding wheel or flap wheel
After expansion	-	Only flap wheels (cosmetic grinding)

**a.** Cosmetic grinding i.e. grain size disk # 100 or flap wheels. Wall thickness check is not required after cosmetic grinding.

**b.** Repairs to HFW weld line: external light grinding is permitted.  
Internal light grinding shall be limited to removing weld flash only.  
Wall thickness shall be checked after light grinding.

**C.2.3 The existing clause shall be deleted and replaced with the following:**

After grinding, complete removal of defects shall be verified by wet or dry MT as per ASTM E709 or ISO 10893-5, and by the NDT method which detected the defect i.e. automatic UT (AUT) or electromagnetic inspection (EMI).

Following ID grinding, MT or liquid penetrant shall be used to verify complete removal of defects:

- a)** If MT or liquid penetrant cannot be performed on the ID, manual or automatic UT (and EMI as applicable) may be used to ensure complete defect removal.
- b)** Any UT procedure for verification of removal of defects by ID grinding shall be submitted to the purchaser for review and acceptance.

Wall thickness measurements shall be made by UT in the ground areas and the results shall be recorded. The wall thickness in the ground area shall be in accordance with Clause 9.11.3.2; however, the minus tolerances for diameter and out-of-roundness (see 9.11.3.1) shall not apply in the ground area.

**C.4 Repair of Defects by Welding**

**C.4.1 Add to this clause the following:**

Weld seams containing cracks shall not be weld repaired. The section of pipe containing cracks shall be cut off. Acceptability of the remaining pipe shall subsequently be based on length requirements.

Inside pipe is considered as a confined space and repairs inside the pipe may only be permitted when safe access procedures are in place. Inside repairs shall be followed by visual inspection.

Unless otherwise specified by the purchaser, inside arc stop/restart repairs for SAW may be allowed if visual inspection (and dressing if required) can be safely performed.

Repair of HFW pipe weld seams by welding is not permitted.

**C.4.2 Add to this clause the following:**

All repairs shall be carried out before cold expansion (if any) and hydrostatic testing.

**C.4.3 The existing clause shall be deleted and replaced with the following:**

The total length of repaired zones on each pipe weld shall be  $\leq 5\%$  of the total weld length for SAW weld seams; unless otherwise specified by the purchaser, weld repairs shall be limited to a maximum of four per pipe with a maximum length of 350 mm (13.8 in.) each.

**C.4.4 The existing clause shall be deleted and replaced with the following:**

Repairs shall be separated by at least 200 mm (7.9 in.). Each repair shall be carried out with a minimum of two layers/passes over a length of at least 50 mm (2.0 in.)

No welding repair is permitted over a length of 254 mm (10.0 in.) from each pipe end.

**C.4.5 Add to this clause the following:**

Welder shall be qualified in accordance with Annex D.3.

The properties of the weld repair shall meet the specification requirements of the longitudinal seam weld.

**C.4.6 The existing clause shall be deleted and replaced with the following:**

The external surface of the repair weld shall be subject to grinding to obtain a uniform appearance and to merge smoothly into the base material.

Each repaired area shall be 100 % examined by ultrasonic and MT testing. Additional radiographic testing shall be performed if specified by the purchaser.



---

**Annex D**  
**(Normative)**  
**Repair Welding Procedure**

**D.1 General****D.1.2 The existing item b in this clause shall be deleted.****D.1.4 The existing clause shall be deleted and replaced with the following:**

Test welds shall be made on pipe.

**D.2 Repair Welding Procedure Qualification****D.2.1 General****D.2.1.1 Add to this clause the following:**

WPS for repair welding shall be qualified as follows:

- a) One partial repair (minimum of  $\frac{2}{3}t$  repair), simulating a defect located on the fusion line;
- b) One shallow repair with two weld passes minimum, simulating a defect located at the weld toe;
- c) Multiple repairs.

Through thickness repairs are not allowed.

Repair welding shall be qualified in a manner realistically simulating the repair situation to be qualified. All repairs shall include a minimum preheating of 100 °C (212 °F), unless the qualification test has shown that a higher temperature is necessary.

Defects in the weld seam may be removed by grinding and repaired by welding carried out by qualified welders, using a previously qualified welding procedure.

**D.2.2 Essential Variables****Add to this clause the following:**

- c) 7) if it is agreed to have electrode under matching with respect to the strength of the base material: change in batch number of the electrode (each batch shall be individually tested).

**D.2.3 Mechanical Testing****D.2.3.4.4 The existing clause shall be deleted and replaced with the following:**

The minimum average absorbed energy (of a set of three test pieces) for each repair weld and its associated HAZ, shall not be less than that specified in 9.8 for the pipe seam weld and HAZ. The test temperature shall be the same as that required for the weld metal and HAZ.

**D.2.3.4.5 Add this clause as the following:**

Sampling of CVN specimens shall be performed in accordance with Figure D.2 for a partial thickness repair. Minor changes in the sampling location may be accepted by the purchaser.

The test temperature and acceptance criteria shall be the same as those required for unrepaired pipe weld and HAZ (see 9.8).

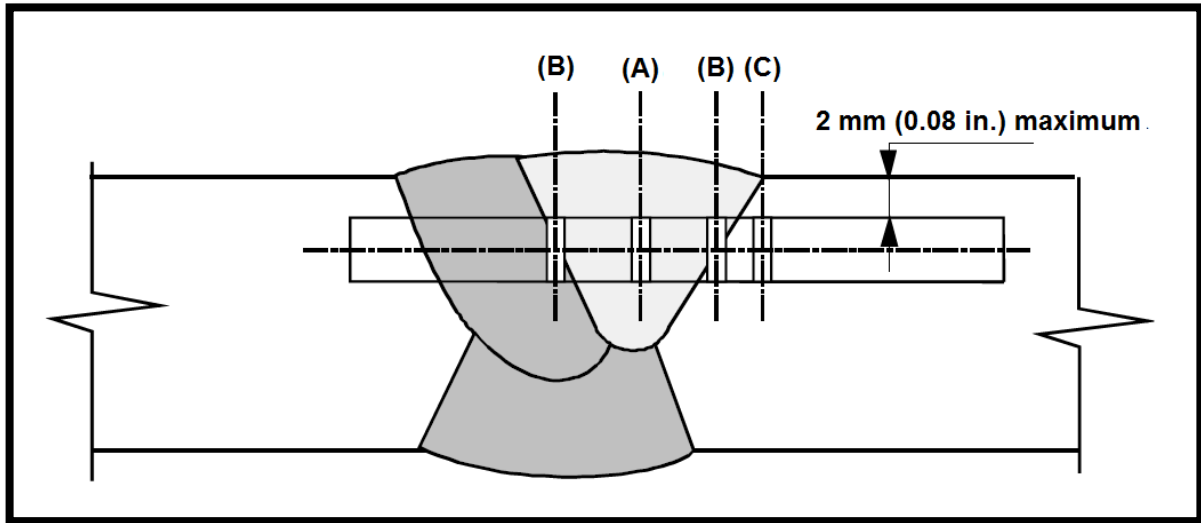
**Key**

- A Weld metal center line.
- B Fusion line of repair weld to base metal and fusion line of repair to original weld.
- C Fusion line + 2 mm (0.08 in.).

**Figure D.2 – Partial Repair Charpy Sampling Location**

**D.2.3.5 Hardness Testing****Add this clause as the following:**

If hardness testing (HV10) is specified for the longitudinal weld, hardness testing shall also be performed on any repairs to the longitudinal weld.

The typical number and position of the indentations shall be as shown in Figure D.3 and D.4.

Acceptance criteria shall be as per Clause 9.17 or applicable annexes and appendices as specified by the purchaser.

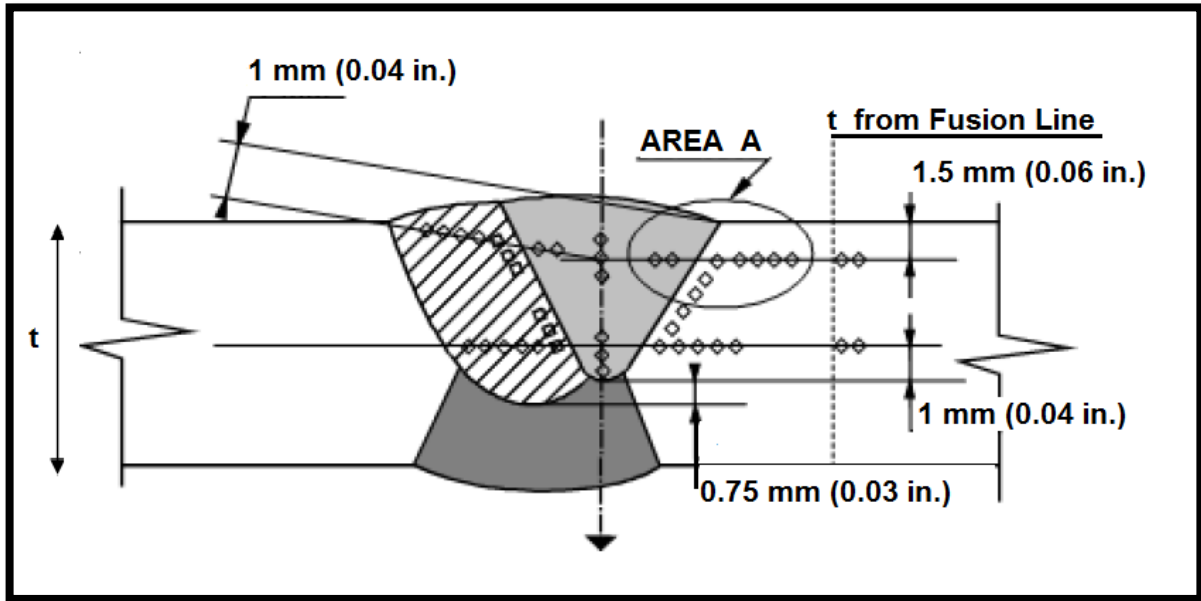

Figure D.3 – Partial repair Hardness Indentation Location

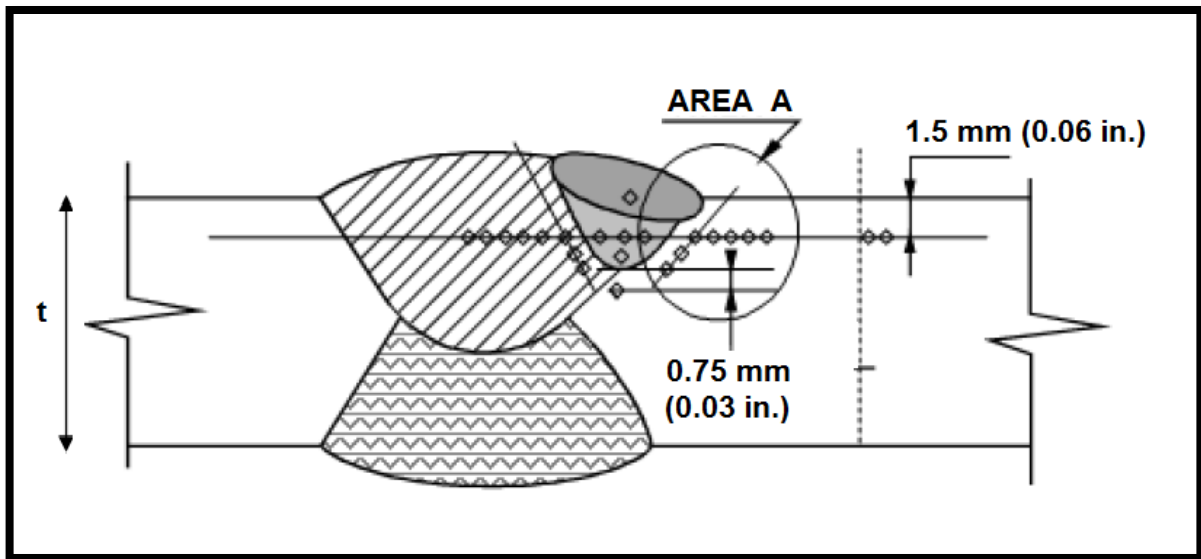

Figure D.4 – Cap Repair Hardness Indentation Location

**D.2.3.6 CTOD Testing**

**Add this clause as the following:**

If CTOD testing is specified by the purchaser, the qualification of a repaired weld shall be subject to the same CTOD testing, except that surface notched specimens shall be used to sample the weld metal and both HAZs (repair/parent material and repair weld/original weld).

An alternative notch specimen may be proposed by the manufacturer as well as approved by the purchaser.

**Note 1:** As per Clause C.4.2, the rim of the cavity shall not extend by more than 3.2 mm (0.126 in.). See Figure C.1.

**D.3 Welding Personnel Performance Qualification****D.3.1 Qualification****D.3.1.1 General****Add to this clause the following:**

Welding operators performing automatic welding may also be qualified according to ISO 14732.

**Annex E**  
**(Normative)**

**Nondestructive Inspection for Pipe Not Required to Meet Annex H, J, or N**

**E.1.3 The existing clause shall be deleted and replaced with the following:**

The manufacturer shall have Level 3 personnel responsible for all NDT activities. The UT Level 3 personnel shall be available on call during manufacture. All of the manufacturer/supplier NDT specifications and procedures shall clearly demonstrate the approval of the NDT Level 3 showing an approval date. When required, the manufacturer shall supply the purchaser or the inspector, the qualification number and the expiry date of the NDT Level 3 individual.

**Note 1:** Evaluations of indications shall be performed by a Level 2 or Level 3 personnel only.

**E.3.1.1 The existing clause shall be deleted and replaced with the following:**

The weld seams and HAZs of welded pipes shall be nondestructively inspected over 100 % of the full length for imperfections, for the entire thickness and width, as specified in Table E.1 and as follows. UT shall be performed in accordance with ISO 10893-11, as amended or supplemented by this annex.

**Note 1:** UT shall be performed using automated equipment with “conventional” or phased array techniques. UT procedures using time of flight diffraction (ToFD) and electromagnetic acoustic transducer (EMAT) equipment shall only be used with the specific written acceptance of the purchaser and on the basis of a specific qualification program accepted by the purchaser.

**Note 2:** Manual UT (MUT) shall not be permitted as a substitute or replacement for AUT.

**Note 3:** If specified by the purchaser, full X-ray supplemented by MUT may be allowed for seam weld inspection.

**Note 4:** Real-time (dynamic) radiography is acceptable if the test results recorded.

**E.3.1.2 The existing clause shall be deleted and replaced with the following:**

All SMLS pipe shall be subject to automated NDT over 100 % of the length and circumference (for transverse, longitudinal and inclined embedded imperfections) as stated in Table E.2.

Unless otherwise specified by the purchaser, the applicable codes for testing are:

- ISO 10893-2, Automated Eddy Current Testing;
- ISO 10893-5, Magnetic Particle Inspection; and
- ISO 10893-10, Automated UT for longitudinal and transverse imperfections.

**The existing Table E.1 shall be deleted and replaced with the following:**

**Table E.1 - Pipe Weld Seam Nondestructive Inspection**

Weld seam type	NDT Method <sup>a</sup>		
	EMI <sup>b</sup>	UT	RT
HFW for $t < 6$ mm	One method or a combination of methods is required		Not applicable
HFW for $t \geq 6$ mm	Not applicable	Required	Not applicable
SAW	Not applicable	Required <sup>c</sup>	Required <sup>d</sup>

**a.** The weld seam at the pipe ends might require additional inspection (see Clause E.3.2).  
**b.** Acceptable EMI method shall be accepted by the purchaser.  
**c.** Required unless the manufacturer and the purchaser have agreed to replace it by radiographic inspection.  
**d.** Required as a minimum on pipe ends.

**The existing Table E.2 shall be deleted and replaced with the following:**

**Table E.2 - SMLS Pipe Body Nondestructive Inspection**

Item	Thickness	NDT Method		
		EMI	UT	MT (circular field)
PSL 2 pipe, any grade	< 6 mm	One method or a combination of methods is required		Not applicable
	$\geq 6$ mm	Not applicable	Required	

**E.3.1.3 The existing clause shall be deleted and replaced with the following:**

- a)** For seamless pipe, NDT should be performed after hydrotesting. Unless otherwise specified by the purchaser, the required nondestructive inspection of SMLS pipe shall take place at least after each heat treating and cold-expansion operations, if performed, but may take place before cropping, beveling, and end sizing;
- b)** For welded pipe, NDT shall be completed after hydrostatic testing. It shall be considered that the required nondestructive inspection of weld seams of cold-expanded pipe shall take place after cold expansion.
- c)** For SAW pipe, NDT shall be done after hydrostatic testing and any sizing practice.

### E.3.2 Pipe End Inspection – Welded Pipe

#### E.3.2.1 Non-inspected Ends

**Add title to E.3.2.1 and the existing clause shall be deleted and replaced with the following:**

For the weld seam at the pipe ends, if an AUT or EMI inspection is applied to meet the requirements of Clause E.3.1.1, the lengths of weld at the pipe ends that are not covered by the automated inspection, up to a maximum of 305 mm (12 in.), shall be inspected for defects using the same inspection parameters as specified in Clause E.3.1.1, by:

- UT using an alternative AUT system or semi-automated UT (SAUT) system; or
- Manual UT (MUT).

MUT shall only be used to inspect the untested ends of weld seams if prior written acceptance has been obtained from the purchaser. Scanning shall be performed in both circumferential directions using adequate shear wave probes. The shear wave probe angle shall be selected to ensure full weld and HAZ coverage.

Alternatively, the non-AUT-inspected pipe ends shall be cut off, with the following conditions:

- a) Non-AUT-inspected weld ends shall not exceed 305 mm (12 in.).
- b) Removal of non-AUT-inspected pipe ends does not remove the manufacturer's obligation to perform radiographic testing (RT) of the weld ends (see Clause E.3.2.2).
- c) Removal of non-AUT-inspected pipe ends does not remove the manufacturer's obligation to perform UT of the pipe ends (see Clauses E.3.2.3 and E.3.2.4).
- d) Where more critical UT acceptance criteria applies to pipe ends than applies to the rest of the pipe, the more critical acceptance criteria shall be applicable to new pipe ends, after non-AUT-inspected pipe ends have been cut off.
- e) Records in accordance with Clause E.5.4 shall be maintained.

#### E.3.2.2 RT of Welds at Pipe Ends

**Add title to E.3.2.2 and the existing clause shall be deleted and replaced with the following:**

For SAW pipe, the weld at each pipe end for a minimum distance of 200 mm (8.0 in.) shall be inspected by the radiographic method. The results of such radiographic inspection shall be recorded on either film or another imaging medium.

Unless otherwise specified by the purchaser, the same area subject to RT shall also be inspected using UT (see Clause E.3.2.1), which shall be taken as the prime inspection method. The final acceptance shall be by UT. RT shall not be used to accept defects detected by UT.

If a defect is detected by any NDT method, it shall be considered rejected.

**Note 1:** RT inspection shall be X-ray unless otherwise specified by the purchaser

#### E.3.2.3 UT for Lamination Check

**Add title to E.3.2.3 and the existing clause shall be deleted and replaced with the following:**

UT shall be carried out in accordance with ISO 10893-8 or an agreed equivalent (e.g. ASTM A578 and ASTM A435) to verify that the whole circumference of both pipe ends is free from laminar imperfections > 6.4 mm (0.25 in.) in the circumferential direction.

Scanning shall be carried out over a distance of  $[3.5t + 25 \text{ mm (0.98 in.)}]$  or 50 mm (2.0 in.), whichever is greater, from the point where the outside surface meets the pipe end face or bevel.

Pipe end UT shall be undertaken from the outside surface and be inspected before beveling. If specified by the purchaser, UT may be carried out after beveling from the inside surface following by MT test (with a suitable technique for laminar imperfection e.g. radially through wall thickness) to

find laminar defect on both bevel faces of pipes in accordance with ISO 10893-5 or ASTM E709; Bevel faces shall be free of indications.

Pipe end lamination check may be performed using MUT.

**Note 1:** If specified by the purchaser, longer scanning distance may be ordered.

#### **E.3.2.4 SAW Pipe End Circumference**

##### **Add this clause as the following:**

UT shall be carried out to verify that at least the 50 mm (2 in.) zone at each pipe end is free of axially-aligned through-thickness cracking. Scanning shall be performed in both circumferential directions using adequate shear wave probes (it should be 45°). Axially-aligned N5 notches on the inside and outside surfaces shall be used to set the reference and acceptance levels. No cracks shall be allowed.

#### **E.3.2.5 MT of End Face**

##### **Add this clause as the following:**

If specified by the purchaser, MT of pipe end face/bevel shall be carried out associated with UT inspection for the detection of laminar imperfections (or other requested imperfections by the purchaser), in accordance with ISO 10893-5 or ASTM E709. The end face shall be free of indications.

#### **E.3.3 Pipe End Inspection – SMLS Pipe**

##### **E.3.3.1 Non-inspected Ends**

##### **Add title to E.3.3.1 and the existing clause shall be deleted and replaced with the following:**

The lengths of the pipe ends that are not inspected during AUT of the pipe body (see Clause E.3.1.2), up to a maximum of 305 mm (12 in.), shall be inspected for defects by an alternative AUT system, SAUT or MUT system using angle beam probes, and the same inspection parameters as specified in Clause E.3.1.2. Scanning shall be performed in both circumferential directions using adequate shear wave probes (it should be 45°).

**Note 1:** MUT shall only be used to inspect the untested ends of pipes if prior written acceptance has been obtained from the purchaser. Scanning shall be performed in both circumferential directions using adequate shear wave probes.

Alternatively, the non-AUT-inspected pipe ends shall be cut off, with the following conditions:

- a) Non-AUT-inspected pipe ends shall be defined and confirmed by a demonstration by the manufacturer.
- b) Where more critical UT acceptance criteria applies to the pipe ends than applies to the rest of the pipe body, the more critical acceptance criteria shall be applicable to the new pipe ends, after non-AUT-inspected pipe ends have been cut off.
- c) Removal of non-AUT-inspected pipe ends does not remove the manufacturer's obligation to perform UT of the pipe ends (see Clauses E.3.3.2).
- d) Records in accordance with Clause E.5.4 shall be maintained.



**E.3.3.2 UT for Lamination Check**

**Add title to E.3.3.2 and the existing clause shall be deleted and replaced with the following:**

For SMLS pipes also consider as Clause E3.2.3.

**E.3.3.3 MT of End Face**

**Add this clause as the following:**

For SMLS pipes also consider as Clause E3.2.5.

**E.4.2.3 The existing clause shall be deleted and replaced with the following:**

Unless otherwise specified by the purchaser, the density of the radiograph shall be between 2.0 and 3.0 in the weld seam and between 2.0 and 3.5 in the parent metal. Film viewers (illuminator) shall be certified for the applicable density ranges.

**E.4.6 Defects Found by Radiographic Inspection**

**Add to this clause as the following:**

Where suspect indications have been recorded by UT but have not been detected during retesting by RT, the area shall be subjected to further UT. If the repeat UT confirms the indication as true and relevant (i.e. not due to geometrical features or coupling conditions), the UT indication shall be classed as a defect and rejected.

**E.5 Ultrasonic and Electromagnetic Inspection****E.5.1.1 Add to this clause the following:**

Unless otherwise specified by the purchaser:

- a) If specified by the purchaser, the system shall be qualified in accordance with Appendix 3.
- b) The NDT system shall be capable of revealing the discontinuities specified by the purchaser and in general, capable of revealing axial and circumferential imperfections (as applicable) in the internal surface, external surface and inner material of pipe, including laminations and segregations. If specified by the purchase, the NDT system shall have capability for oblique imperfection detection.
- c) Equipment shall be capable of automatic paint spray marking of defects or, if agreed with the purchaser, systems that record defect positioning with inspection maps may be accepted. Unless otherwise specified by the purchaser, every four hours, each paint spray, including those of coupling failure, shall be activated in order to clean out the spray nozzle.
- d) Scanning systems for AUT of plate or strip(coil) shall enable 100 % coverage of the plate/ strip(coil) area, and coverage of the full thickness of the plate or strip(coil).
- e) Scanning systems for AUT of the pipe weld seam or pipe body shall enable 100 % coverage in one continuous pass. Coverage shall include the full depth and width of the seam and HAZs of welded pipe (HAZs shall be considered to be at least 3.0 mm (0.12 in.) wide). Unless otherwise specified by the purchaser, multiple carriages may be used together or separately.
- f) For seamless pipes, coverage shall include the inside and outside surfaces and full thickness of the pipe.
- g) For welded pipe, an automated weld tracking system for correct positioning of the probes with respect to the weld centerline shall be used, capable of a positional accuracy of  $\pm 2$  mm (0.08 in.) or better.
- h) Any indication above the recording level shall be automatically marked on the pipe surface.

### E.5.1.2 Weld seam coverage

**The existing clause shall be deleted and replaced with the following:**

Unless otherwise specified by the purchaser, for welded pipe, the equipment shall be capable of testing the entire length of the weld area (except for weld ends subject to separate AUT, SAUT or MUT, as applicable) and the entire thickness of the weld area as follows:

- a) For HFW, the weld area (including weld seam and HAZ) plus at least 1.6 mm (0.063 in.) of adjacent parent metal on each side of the weld area.
- b) For SAW, the weld area (including weld seam and HAZ) plus at least 1.6 mm (0.063 in.) of adjacent parent metal on each side of the weld area.

**Note 1:** The precision of the weld tracking device shall be taken into account.

### E.5.1.3 Manual UT

**Add this clause as the following:**

MUT equipment shall only be used to:

- a) Inspect non-AUT-inspected plate edges and plate ends;
- b) Inspect non-AUT-inspected pipe ends, if prior written acceptance has been obtained from the purchaser;
- c) Verify indications recorded by AUT; and
- d) Confirm the rejection or acceptance of indications.

**Note 1:** Unless otherwise specified by the purchaser, recording levels used during MUT shall be equivalent to those used during AUT and the MUT scanning speed shall not exceed 150 mm/s (6 in/s).

**Note 2:** Unless otherwise specified by the purchaser, MUT for detection of laminar imperfections shall be performed in accordance with ISO 10893-9 (Annex A) and dual transducer probes shall be used.

### E.5.1.4 Probes Used for AUT

**Add this clause as the following:**

Probes used for AUT shall:

- a) Enable the sensitivity and scanning coverage required;
- b) Be provided with probe data sheets demonstrating the manufacturer, type, beam angle, dimensions, frequency distribution and focusing;
- c) Unless otherwise specified by the purchaser, for angle beam probes used for UT of weld seams, be provided with data sheets that illustrate the vertical -6 dB beam profile; and
- d) Unless otherwise specified by the purchaser, for normal (0°) beam probes, be provided with data sheets that illustrate the lateral -6 dB beam profile.

## E.5.2 Ultrasonic and Electromagnetic Inspection Reference Standards

### E.5.2.1 Add to this clause the following:

The design and material of reference standards shall be agreed with the purchaser, prior to use.

**E.5.2.2 The existing clause shall be deleted and replaced with the following:**

Reference standards may be of any convenient length, as determined by the manufacturer and accepted by the purchaser.

Unless otherwise specified by the purchaser, reference standards used for dynamic demonstration and repeatability testing shall be full production length.

**E.5.2.3 The existing Table E.7 shall be deleted and replaced with the following:**

**Table E.7 - Reference Indicators**

Item	Reference Indicators <sup>a</sup>							
	Notch Location		Notch Orientation		Notch Dimensions			Diameter of Radially Drilled Hole <sup>b</sup> (mm)
	OD	ID	Longitudinal	Transverse	Depth <sup>c</sup> (%)	Length <sup>d</sup> Max.(mm)	Width Max.(mm)	
HFW Seam	e , i	e , i	Required <sup>i</sup>	Required <sup>h</sup>	5.0	50	1.0	1.6 <sup>i</sup>
SAW Seam <sup>g</sup>	e	e	Required	Required	5.0 <sup>f</sup>	50	1.0	1.6 <sup>f</sup>
SMLS Pipe	e	e	Required <sup>h</sup>	Required	5.0	50	1.0	1.6 <sup>j</sup>

**Note 1:** Notches are rectangular or U-shaped.  
**Note 2:** For electromagnetic inspection, the reference standard shall contain OD notches, ID notches, and a radially drilled hole (see Clause E.5.3.4).

**a.** It is not necessary to locate reference indicators in the weld.  
**b.** Drilled hole diameters are based on standard drill-bit sizes. A hole is not required if a notch is used to establish the reject threshold.  
**c.** Depth is expressed as a percentage of the specified wall thickness. It is not necessary that the depth be less than 0.3 mm (0.012 in.). The depth tolerance is  $\pm 15\%$  of the specified notch depth or  $\pm 0.05$  mm (0.002 in.), whichever is the greater.  
**d.** Length at full depth.  
**e.** Required if a notch is used to establish reject threshold.  
**f.** At the option of the manufacturer and specified by the purchaser, N10 notches or 3.2 mm (0.125 in.) holes may be used (see Table E.8 for applicable acceptance limits).  
**g.** At the option of the manufacturer and specified by the purchaser, for SAW seams, the reject threshold may be established using weld-edge notches or weld-edge radially drilled holes.  
**h.** At the option of the manufacturer and specified by the purchaser, the notches may be oriented at an angle that would facilitate the detection of anticipated defects.  
**i.** If specified by the purchaser, the reference standard shall contain OD and ID notches and a radially drilled hole.  
**j.** If specified by the purchaser, the diameter of radially drilled hole may be 3.2 mm.

**E.5.2.5 Add to this clause the following:**

Visual and dimensional inspection shall be carried out on each reference standard and the results shall be included in a formal report or certificate, demonstrating compliance with the requirements of this specification and the applicable design. NDT methods may be used to provide additional information. The following shall be included as a minimum requirement:

- a) Report identification, date, purchaser name, authorizing name and signature.
- b) Reference standard: identification, length, diameter, thickness, material, weld procedure and weld profile (as appropriate), scanning surface profile, and reference reflector locations.
- c) N5 / N10 notches: length, width, depth, angle and cross-section.
- d) RDH (radially-drilled hole): diameter, location, angles in two perpendicular planes.
- e) If FBH (flat bottom hole) specified by the purchaser for weld: diameter, drilled depth, depth below surface, location of end relative to fusion line, angles in two perpendicular planes, and confirmation of flatness and perpendicularity of end.
- f) If FBH (flat bottom hole) specified by the purchaser for plate/ strip (coil): diameter, drilled depth, depth below surface, angles in two perpendicular planes, and confirmation of flatness and perpendicularity of end.
- g) If SDH (side-drilled hole) specified by the purchaser: diameter, drilled length, depth below surface, location, angles in two planes.

**E.5.5.1 The existing Table E.8 shall be deleted and replaced with the following:**

**Table E.8 - Acceptance Limit**

Item	Notch Type	Hole Size (mm)	Acceptance Limit <sup>a</sup> Max. (%)
SAW or repair weld	N5	1.6	100
	N10 <sup>b</sup>	3.2 <sup>b</sup>	33 <sup>b</sup>
Electric weld	N5	1.6 <sup>c</sup>	100
SMLS pipe	N5	1.6 <sup>c</sup>	100

**a.** Expressed as a percentage of the indication produced by the reference indicator. The reject threshold (see Clause E.5.3) shall not exceed the applicable acceptance limit.  
**b.** If accepted and specified by the purchaser in order.  
**c.** If specified by the purchaser, the hole size may be 3.2 mm.

**E.5.8 UT Inspection for Delayed Hydrogen Cracks (Chevron Cracking) Detection**

**Add this clause as the following:**

If specified by the purchaser, during MPQT and production, MUT inspection for delayed hydrogen cracking (DHC) shall be performed as specified procedure. AUT may be applied when agreed with the purchaser. AUT procedures and reference pipes shall also be agreed with the purchaser. When AUT is applied, adequate reference flaws shall be added to the reference standard, to assure 100 % coverage of the weld.

**Note 1:** The inspection is limited to SAW pipes and expected DHC Location and Orientation is indicated in Figure E.1.

**Note 2:** Unless otherwise specified by the purchaser, one pipe per shift shall be selected or 2 % of produced pipes per day, whichever is greater.

**Note 3:** 100 % of the weld seams shall be tested 48 hours after hydrotest.

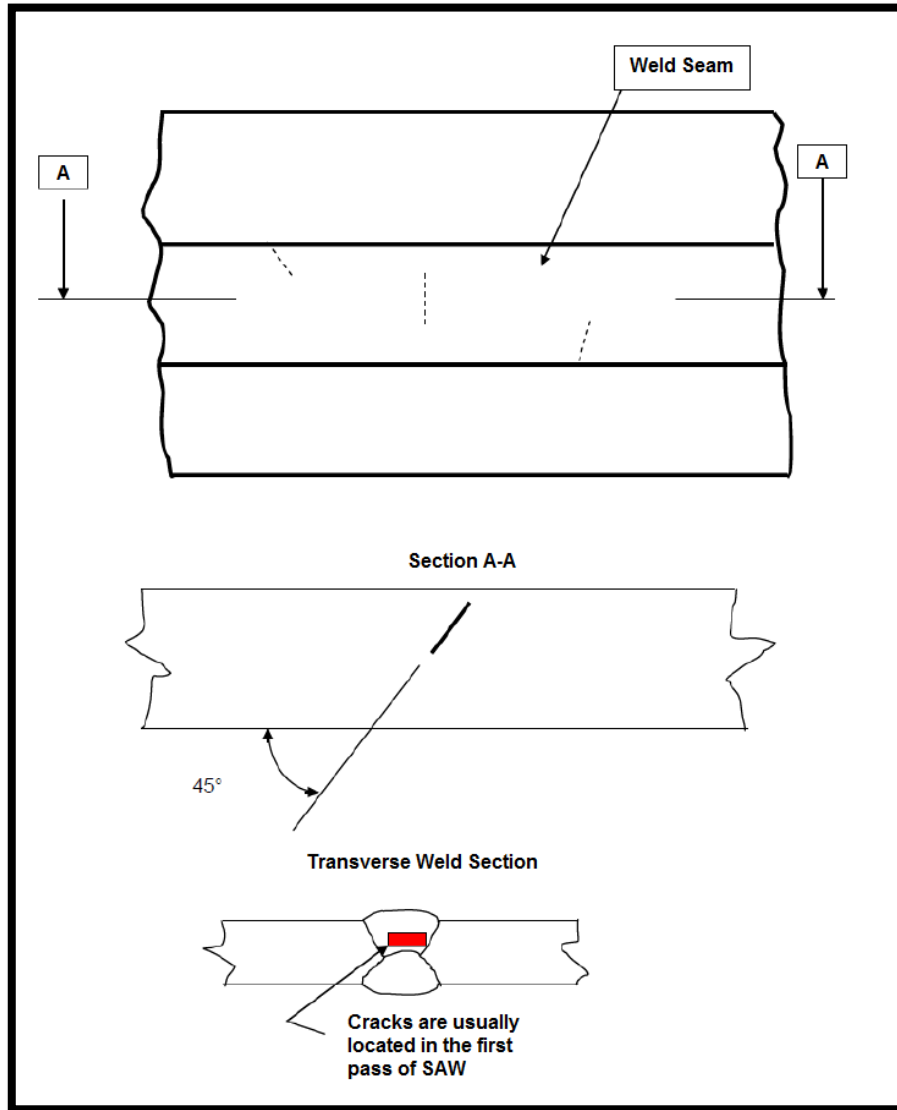

Figure E.1 – Expected DHC Locations and Orientations

**E.6 Magnetic Particle Inspection**

**E.6.1.2 The existing clause shall be deleted and replaced with the following:**

Surface imperfections revealed by magnetic particle inspection shall be investigated, classified, and treated as Clause 9.10.7.

**E.6.2 Equipment**

**Add to this clause the following:**

Magnetization shall be carried out in two perpendicular directions for pipe bodies and in at least one direction (for circumferential defects) for pipe end bevels.

**E.6.4 MT of Long Seam for SAW****Add this clause as the following:**

If specified by the purchaser during MPQT and production, the full seam weld of one pipe per shift shall be inspected 48 hours minimum after welding.

**Note 1:** Magnetic particle testing shall be performed in accordance with ASTM E709.

**Note 2:** For pipe with  $D \geq 609.6$  mm (24 in.), the entire internal weld shall be MT inspected.

**Note 3:** Indications  $> 3.2$  mm (0.125 in.) in any direction shall be classified as defects.

**Note 4:** Cracks are not acceptable.

**E.7.4 The existing clause shall be deleted and replaced with the following:**

Measurements shall be made on each end of a pipe, selected at least three times per 4 h per operating shift.

**E.7.6 The existing clause shall be deleted and replaced with the following:**

Unless otherwise specified by the purchaser, four readings shall be taken approximately  $90^\circ$  apart around the circumference of each end of the pipe. The average of the four readings shall be  $\leq 2.0$  mT (20 Gs), and no one reading shall exceed 2.5 mT (25 Gs) when measured with a Hall-effect gaussmeter or equivalent values when measured with another type of instrument that is approved by the purchaser.

**E.8 Laminar Imperfections in the Pipe Body of HFW, SAW and SMLS Pipe****Add "SMLS" to existing E.8 title.****E.8.1 The existing clause shall be deleted and replaced with the following:**

For HFW pipe, ultrasonic inspection shall be used to verify that the pipe body is free of laminar imperfections greater than those permitted by:

- a) ISO 10893-9 (Unless otherwise specified by the purchaser, acceptance level U2), if such inspection is done prior to pipe forming, or
- b) ISO 10893-8 (Unless otherwise specified by the purchaser, acceptance level U2), if such inspection is done after seam welding.

**Note 1:** Unless otherwise specified by the purchaser, the scanning coverage shall be at least 50 % of the area of the strip (coil) or pipe body. The scanning coverage may be increased up to 100% of the area of the strip (coil) or pipe body, at the COMPANY's discretion.

**E.8.2 The existing clause shall be deleted and replaced with the following:**

For SAW pipe, ultrasonic inspection shall be used to verify that the strip(coil)/plate (or the pipe body) is free of laminar imperfections greater than those permitted by ISO 10893-9 acceptance level U2.

**Note 1:** Unless otherwise specified by the purchaser, the scanning coverage shall be at least 50 % of the area of the strip(coil)/plate or pipe body. The scanning coverage may be increased up to 100% of the area of the strip(coil)/plate or pipe body, at the COMPANY's discretion.

**Note 2:** If specified by the purchaser, ISO 10893-8 (acceptance level U2), shall be considered for such inspection after seam welding.

**E.8.3 Add this clause as the following:**

For SMLS pipes, ultrasonic inspection shall be used to verify that the body of pipe is free of laminar imperfections greater than those permitted by ISO 10893-8 acceptance level U2.

**Note 1:** Unless otherwise specified by the purchaser, the scanning coverage shall be at least 50 % of the area of the pipe body. The scanning coverage may be increased up to 100% of the area of the pipe body, at the COMPANY's discretion.

**Note 2:** If specified by the purchaser, ISO 10893-8 acceptance level U1 may be used.

**Note 3:** EMT may be applied for nominal wall thickness less than 6mm, according to Table E.2.

**E.9 Laminar Imperfections along the Strip/Plate Edges or Weld Seam of HFW and SAW Pipe****The existing clause shall be deleted and replaced with the following:**

For HFW and SAW pipes, ultrasonic inspection shall be used to verify that at least the [3.5t + 25 mm (0.98 in.)] or 50 mm (2.0 in.), whichever is greater, wide zone along each of the strip(coil)/plate edges or along each side of the pipe weld seam is free of laminar imperfections greater than those permitted by:

- a) ISO 10893-9 acceptance level U2, if such inspection is done prior to pipe forming, or
- b) ISO 10893-8 acceptance level U2, if such inspection is done after seam welding.

**Note 1:** The scanning coverage shall be 100 % of the area.

**Note 2:** If specified by the purchaser, for pipes, UT for detection of laminar imperfections shall be performed on both the plate and along the pipe weld seam.

**Add this clause as the following:****E.11 Thickness Measurement****Add this clause as the following:****E.11.1 Seamless Pipes**

For SMLS pipes, full peripheral ultrasonic thickness measurements shall be carried out in accordance with ISO 10893-12 or ASTM E114 for verification of compliance with the applicable minimum permissible wall thickness requirement. Scanning coverage shall be at least 25 % of the area of the pipe.

**Note 1:** Unless otherwise specified by the purchaser, manually ultrasonic thickness measurements shall be done approximately within 50 mm (2.0 in.) of each pipe end at least at four locations circumferentially each 90 degree apart.

**Add this clause as the following:****E.11.2 Welded Pipes****Add this clause as the following:****E.11.2.1 Steel Plate Wall Thickness Measurement**

Unless otherwise specified by the purchaser, wall thickness checks shall be performed, as a minimum four locations equally apart on the straight line in the middle and edges of the each plates (i.e. twelve measurements on each plate).

Steel plate thickness measurements shall be such that the specified minimum and maximum wall thickness of finished pipes are met.

---

**Add this clause as the following:****E.11.2.2 Pipe Wall Thickness Measurement**

For SAW pipe, unless otherwise specified by the purchaser, manually ultrasonic thickness measurements shall be done approximately within 50 mm (2.0 in.) of each pipe ends at least at three locations circumferentially, approximately 20 mm (0.79 in.) from weld toes of both sides of seam weld and on the opposite side to the seam weld (i.e. six measurements on each pipe).

**Note 1.** If specified by the purchaser, (specially when steel plate thickness measurement had not carried out), manually ultrasonic thickness measurement, at least in the middle of the each SAW pipe should be done associated with ends of each pipe as above.

For HFW pipe, unless otherwise specified by the purchaser, manually ultrasonic thickness measurements shall be done approximately within 50 mm (2.0 in.) of each pipe ends at least at three locations circumferentially, approximately 20 mm (0.79 in.) from edges of both sides of seam weld and on the opposite side to the seam weld (i.e. six measurements on each pipe).

**Note 2.** If specified by the purchaser, manually ultrasonic thickness measurement in the middle of each HFW pipe should be done associated with ends of each pipe as above.

**Add this clause as the following:****E.12 Calibrations, Control Checks and Maintenance**

NDT equipment, facilities, consumables and processes shall be subject to a documented system of routine calibrations, control checks and maintenance. NDT equipments shall be calibrated at least once per 4 hours operating shift.



---

**Annex H**  
**(Normative)**

**PSL 2 Pipe Ordered for Sour Service**

### **H.1 Introduction**

#### **Add to this clause the following:**

Material supplied according to this annex shall also comply with NACE MR0175/ISO 15156. Where conflicting requirements arise, the most stringent requirement shall apply.

Pipe that has not been intentionally manufactured to be HIC resistant steel shall not be used, even if it has passed subsequent HIC tests.

In case of conflict between clauses of part II in this standard and this Annex requirements, the most stringent requirements shall be applied for pipe ordered for sour service.

### **H.3 Manufacturing**

#### **H.3.2.1 Add to this clause the following:**

All pipes shall be manufactured in accordance with a manufacturing procedure that has been qualified to the requirements of Annex B, supplemented with additional testing specified within Annex H (refer to Table H.3). Beside the requirements of Clause 8.3.3 and unless otherwise specified by the purchaser, the followings shall be considered:

1. Sulfur print testing shall be carried out for the steel used for the manufacture of pipe to reveal the segregation and distribution of sulfide inclusions to ensure the uniformity of productions. The test results shall not exhibit segregations. Unless otherwise specified by the purchaser, the inspection frequency shall be at least one sample per each five heat No. or charge No. (whichever applicable) under the same manufacturing conditions.
2. The base metal shall have inclusion ratings in accordance with ASTM E45 method D. The severity level, not higher than the severity 1 should be considered for all types of heavy and thin inclusions (i.e. types A,B,C and D inclusions).  
Unless otherwise specified by the purchaser, the inspection frequency shall be at least one sample per each five heat No. or charge No. (whichever applicable) under the same manufacturing conditions.
3. The steel used for the manufacture of pipe, at location  $\frac{1}{4}t$  and  $\frac{1}{2}t$  shall be examined for a banded structure (i.e. ferrite or pearlite/martensite). Acceptance criteria shall be agreed between the manufacturer and the purchaser; it should be no banded. Unless otherwise specified by the purchaser, the inspection frequency shall be at least one sample per each five heat No. or charge No. (whichever applicable) under the same manufacturing conditions.
4. The steel used for the manufacture of pipe shall not exhibit banded structure in terms of carbon / carbides segregation. Unless otherwise specified by the purchaser, the inspection frequency shall be at least one sample per each five heat No. or charge No. (whichever applicable) under the same manufacturing conditions.
5. The degree of banding or orientation of microstructure measurement (and bidirectional mechanical tests, if required by the purchaser) for SMLS and welded pipes shall also be carried out after final mechanical and thermal processes of pipe manufacturing to ensure achieving acceptance criteria that is comply with related requirements for ordered pipes.

**H.3.2.2 Add to this clause the following:**

The gas content of Oxygen, Hydrogen and Nitrogen within molten steel or product shall be checked online (and documented) and be equal or less than 25 ppm, 2 ppm and 80 ppm, respectively. The inspection frequency shall be at least one sample per heat No. under the same manufacturing conditions.

**H.3.2.3 The existing clause shall be deleted and replaced with the following:**

The molten steel shall be treated for inclusion shape control. A procedure (e.g. metallographic examination) may be agreed between the purchaser and the manufacturer to assess the effectiveness of inclusion shape control.

**H.3.3 Pipe Manufacturing****H.3.3.1 SMLS Pipe****The existing clause shall be deleted and replaced with the following:**

SMLS pipe shall be manufactured from continuously cast (strand cast) or ingot steel if specified by the purchaser. If the process of cold finishing was used, this shall be stated in the inspection document.

**H.3.3.2 Welded Pipe****H.3.3.2.1 The existing clause shall be deleted and replaced with the following:**

Strip (coil) and plate used for the manufacture of welded pipe shall be rolled from continuously cast (strand cast) or pressure cast slabs. The pipe shall be SAWL, SAWH or HFW.

**H.3.3.2.2 The existing clause shall be deleted and replaced with the following:**

For HFW pipe, the abutting edges of coil or plate shall be machined or milled.

**Note 1:** Unless otherwise specified by the purchaser, shearing is not permitted.

**H.3.3.2.4 The existing clause shall be deleted and replaced with the following:**

For HFW pipe, such coil and plate shall be inspected ultrasonically for laminar imperfections or mechanical damage in accordance with K.4, either before or after cutting the coil or plate, or the completed pipe shall be subjected to full-body inspection, including ultrasonic inspection.

**H.3.3.2.5 The existing clause shall be deleted and replaced with the following:**

Strip(coil)/plate end welds are not permitted.

**H.3.3.2.6 The existing clause shall be deleted and replaced with the following:**

Intermittent tack welding of the SAWL groove shall not be used.

**H.3.3.2.7 Add this clause as the following:**

If specified by the purchaser, welding consumables shall comply with Appendix 1.

### H.3.4 Cold Sizing and Cold Expansion

**Add this clause as the following:**

Unless otherwise specified by the purchaser, the sizing ratio shall be recorded for ten pipes per shift (evenly distributed throughout production) or every 10 pipes per shift, whichever is greater, and also on MPQT pipe used for qualification of the MPS.

### H.4 Acceptance Criteria

#### H.4.1 Chemical Composition

**H.4.1.1 The existing clause shall be deleted and replaced with the following:**

For PSL 2 pipe with  $t \leq 25.0$  mm (0.984 in.), the chemical composition for standard grades shall be according to all requirements of Clause 9.2 and modified by Table H.1; In case of conflict between them, the most stringent requirements shall be applied for pipe ordered for sour service.

The pipe designation shall be as given in Table H.1 and consists of an alpha or alphanumeric designation that identifies the grade, followed by a suffix that consists of a letter (N, Q, or M) that identifies the delivery condition and a second letter (S) that identifies the service condition.

**Note 1:** The footnotes "d", "e" and "h" of Table H.1 are not permitted unless specified by the purchaser.

**Note 2:** The footnotes "c", "f", "i", "j" and "k" of Table H.1 shall be carried out unless otherwise specified by the purchaser.

**Note 3:** In case of conflict among chemical requirements of API 5L and chemical requirements of this standard, the requirements of this standard shall be carried out.

**H.4.1.2 The existing clause shall be deleted and replaced with the following:**

For PSL 2 pipe with  $t > 25.0$  mm (0.984 in.), the chemical composition shall be agreed with the purchaser, this standard and with the requirements of Table H.1 being amended as appropriate.

#### H.4.2 Tensile Properties

**The existing clause shall be deleted and replaced with the following:**

The tensile properties shall be in accordance with Clause 9.3 and Table H.2.

Unless otherwise specified by the purchaser, maximum ratio  $R_{t0.5} / R_m$  in Table H.2, for pipe grades from B to X65 shall be changed to 0.90.

**Add to footnote "e" in Table H.2, the following:**

The specified minimum elongation,  $A_r$ , not be less than 20%.

**Add footnote "f" to Table H.2:**

**Footnote f:** Unless otherwise specified by the purchaser, the measured yield strength values shall not exceed the minimum values which are indicated in Table H.2, by more than 120 MPa.

#### H.4.3 HIC/SWC Test

**Add to this clause the following:**

**Note 1:** Unless otherwise specified by the purchaser, detection of HIC shall be carried out by ultrasonic testing.

**Note 2:** If specified by the purchaser, evaluation of HIC shall be carried out by ultrasonic testing and the followings shall be considered:

1. Crack sensitivity ratio, crack length ratio and crack thickness ratio limits shall apply to each section of pipe.
2. Alternative acceptance criteria (to be specified by the purchaser) shall apply.
3. Crack area ratio (CAR) = 5 % maximum of the specimen area, per specimen. The CAR shall include all cracks and all laminations whether they are associated with cracks or not.
4. Damage due to hydrogen pressure induced cracking related features such as blistering, straight and stepwise cracks shall be measured and reported.

#### H.4.4 Hardness Test

**The existing clause shall be deleted and replaced with the following:**

For test pieces subjected to a hardness test (see H.7.3), the hardness in the pipe body, the weld, and HAZ shall be  $\leq 250$  HV10 or 22 HRC (70.6 HR 15N).

#### H.4.5 SSC Test

**The existing clause shall be deleted and replaced with the following:**

After removal of the SSC test specimens (see H.7.3.2) from the test medium, the specimen surface previously under tension shall be examined under a low-power microscope at X100 magnification. The occurrence of any surface breaking fissures or cracks on the tension surface of the test specimen shall constitute failure of the specimen unless it can be demonstrated that these are not the result of SSC.

**Note 1:** Only SSC or stress orientated hydrogen induced cracking (SOHIC) cracks shall be considered for evaluation.

**Note 2:** If specified by the purchaser, test results shall be assessed as per NACE TM 0316, Sec. 9.

#### H.4.6 Fracture Toughness

**Add this clause as the following:**

If specified by the purchaser, additional CTOD testing shall be performed in the environment also defined in the purchase order.

The manufacturer shall submit a CTOD testing procedure for review and approval by the purchaser.

#### H.5 Surface conditions, imperfections and defects

**H.5.2 The existing clause shall be deleted and replaced with the following:**

For welded pipe hard spot shall be classified as a defect if its hardness, based upon individual indentations, exceeds 250 HV10, 22 HRC or 240 HBW. Pipes that contain such defects shall be treated in accordance with subclauses "b" and "c" of Clause C.3.

**H.7 Inspection**

**The existing Table H.3 shall be deleted and replaced by the following:**

**Table H.3 - Inspection Frequency.**

No	Type of inspection	Type of pipe	Frequency of inspection
1	Hardness testing of pipe with D < 508 mm (20.000 in.).	SMLS, HFW, SAWL.	Once per test unit of not more than 100 lengths of pipe with the same coldexpansion ratio <sup>a</sup> .
2	Hardness testing of pipe with D ≥ 508 mm (20.000 in.).	SMLS, HFW, SAWL.	Once per test unit of not more than 50 lengths of pipe with the same coldexpansion ratio <sup>a</sup> .
3	Hardness testing of hard spots in welded pipe.	HFW, SAWL.	Each hard spot found on the internal or external surface of the pipe.
4	Hardness testing of the longitudinal seam weld of welded pipe.	HFW, SAWL.	Once per test unit of not more than 50 lengths of pipe with the same cold-expansion ratio <sup>a</sup> .
5	Metallographic testing for banding and inclusion evaluations .	SMLS, HFW, SAWL.	Unless otherwise specified by the purchaser, it shall be performed once per each five heat.
6	Pipe diameter and out-of-roundness for pipe.	SMLS, HFW, SAWL.	All pipe.
7	Non-destructive inspection.	SMLS, HFW, SAWL.	In accordance with Annex K.
8	HIC test.	SMLS, HFW, SAWL.	Unless otherwise specified by the purchaser, One test for each of the first three heats applied; thereafter, not less than one test per each ten heats of steel.
9	SSC test.	SMLS, HFW, SAWL.	Unless otherwise specified by the purchaser, One test for each pipe provided for manufacturing procedure qualification test (MPQT).  If specified by the purchaser, One test for each of the first three heats applied; thereafter, not less than one test per each ten heats of steel.

a. The cold-expansion ratio is designated by the manufacturer and is derived using the designated before-expansion outside diameter or circumference and the after-expansion outside diameter or circumference; an increase or decrease in the coldexpansion ratio of more than 0.002 requires the creation of a new test unit.

**H.7.2 Samples and Test Pieces for Mechanical and Technological Tests**

**H.7.2.1 General**

**H.7.2.1.3 Add this clause as the following:**

For HIC and SSC testing, detailed drawings of test specimens sampling for MPQT and production tests shall be issued by the manufacturer and submitted for the purchaser’s approval, as part of the MPS. These drawings shall:

- a) Precisely define the specimen location (along the length, around the circumference and in the pipe wall thickness); and
- b) Give a unique identification number for each test specimen.

### H.7.2.2 Samples for HIC/SWC Tests

#### **Add to this clause the following:**

Unless otherwise specified by the purchaser, the following shall be considered:

For SMLS pipes, three sets of three specimens shall be taken from each test pipe as follows: one set cut in the base material in a direction parallel to the rolling direction at each of the three 120° location (i.e. 120° x 3 equally spaced = 9 specimens).

For welded pipes, three sets of specimens shall be taken from each test pipe as follows:

- a) One set of three specimens cut transverse to the longitudinal weld.  
For HFW, the set shall be sampled parallel to the weld for the weld area of HFW line pipe. The weld shall be approximately on the centerline of the test specimens.
- b) Two sets cut in base material in a direction parallel to the rolling direction: one at 90° and one at 180° from the weld.
- c) For MPQT testing, an additional two sets: one at each pipe end (head and tail of the mother plate) shall be tested.

### H.7.2.3 Samples and Test Pieces for SSC Tests

#### **H.7.2.3.1 Add to this clause the following:**

Unless otherwise specified by the purchaser, the following shall be considered:

For SMLS pipes, three sets of three specimens shall be taken from each test pipe as follows: one set cut in the base material in a direction parallel to the rolling direction at each of the three 120° location (i.e. 120° x 3 equally spaced = 9 specimens).

For welded pipes, three sets of specimens shall be taken from each test pipe as follows:

- a) One set of three specimens cut transverse to the longitudinal weld.  
For HFW, the set shall be sampled parallel to the weld for the weld area of HFW line pipe. The weld shall be approximately on the centerline of the test specimens.
- b) Two sets cut in the base material in a direction parallel to the rolling direction: one at 90° and one at 180° from the weld.
- c) For MPQT testing, an additional two sets: one at each pipe end (head and tail of the mother plate) shall be tested.

#### **H.7.2.3.2 The existing clause shall be deleted and replaced with the following:**

Test pieces for four-point bending SSC tests shall be  $\geq 115$  mm (4.5 in.) long  $\times$  15 mm (0.59 in.) wide  $\times$  5 mm (0.20 in.) thick. For welded pipe, the test piece shall contain the longitudinal (or helical) weld in the middle of the tested area and the test piece shall be oriented transverse to the weld seam (Figure 5 b) and c) Key 1). For seamless pipe, the sample shall be oriented longitudinal to the pipe body (Figure 5 a) Key 1). If agreed, samples may be flattened. Unless otherwise specified by the purchaser, samples shall be machined from the inside surface of the pipe.

Unless otherwise specified by the purchaser, the following shall be considered:

- a) Each specimen shall have the following dimensions: 115 mm (4.53 in.) to 140 mm (5.51 in.) long, 15 mm wide (0.59 in.) and 5 mm (0.20 in.) thick.
- b) Only samples free of defects shall be used. Regardless of the pipe wall thickness  $t$ , the set of specimens shall be cut as close as possible to the surface in contact with the fluid containing H<sub>2</sub>S (inside or outside), with a minimum depth of machining to obtain flat surfaces.
- c) Unless otherwise specified by the purchaser, all surfaces shall be polished to 600 grit after machining. Samples identification shall be performed on each specimen by an accepted method.

- d) If requested by the purchaser, test specimens shall have the surface in contact with fluid in the original condition with no subsequent surface preparation (refer to NACE TM 0316).
- e) If a full ring test is specified by the purchaser, test sample and specimen reference shall be made to BS 8701.

**H.7.2.4 Samples for Hardness Tests**

**The existing clause shall be deleted and replaced with the following:**

Samples for hardness tests shall be taken from the end of selected pipes, and, for welded pipe, each sample shall contain a section of the longitudinal seam at its center (see Figure H.1).

**The existing Table H.4 shall be deleted and replaced by the following:**

**Table H.4 - Number, Orientation, and Location of Test Pieces per Sample for Hardness Tests**

Type of pipe	Sample location	Number, Orientation, and Location of Test Pieces <sup>a b</sup>	
		Specified Outside Diameter	
		D mm (in)	
		< 508 (20.000)	≥ 508 (20.000)
<b>SMLS</b>	Pipe body	4T	4T
<b>SAWL/HFW</b>	Pipe weld	1W	1W
	Pipe body	3T	3T

a. Test piece shall be spaced by 90° (all four quadrants of the selected pipe).  
b. Refer to API 5L, Figure 5 for an explanation of the symbols used to designate orientation and location.

**H.7.3 Test Methods**

**H.7.3.1 HIC/SWC Test**

**H.7.3.1.2 The existing clause shall be deleted and replaced with the following:**

HIC and SWC tests shall be conducted in a medium complying with NACE TM0284, Solution A.

The manufacturer shall prepare a detailed HIC test procedure, if not included as part of the MPS, and submit it to the purchaser for prior acceptance. The procedure shall include as a minimum:

- a) A description of the HIC testing setup/apparatus (schematic required) to be used.
- b) The purity of the utilized salts and H<sub>2</sub>S for the test solution.
- c) A detailed procedure describing the testing.
- d) Metallographic preparation and evaluation of HIC specimens.

**H.7.3.1.3 Add to this clause the following:**

If specified by the purchaser based on service condition, this clause may be used.

**H.7.3.1.4 The existing clause shall be deleted and replaced with the following:**

Values of crack-length ratio, crack-thickness ratio and crack-sensitivity ratio shall be reported.

Photographs of etched and un-etched sections of any reportable crack shall be provided with the report at a suitable magnification.

Unless otherwise specified by the purchaser, in addition to the requirements of NACE TM 0284, the following data shall be provided in the manufacturer's report for each heat tested, for the purchaser's acceptance:

- 
- a) The CAR percentage result for each specimen (If UT testing is specified by the purchaser).
  - b) Locations and dimensions of specimens in tested pipe.
  - c) All pertinent explanations (where needed) and concluding comments.
  - d) Any failure shall be analyzed by the manufacturer and the cause of failure made clear to the purchaser.
  - e) For tests on HFW pipe, sections containing the weld seam shall be metallographically examined at magnifications of at least 100X for any evidence of cracking at the weld line in the through-thickness direction and all such indications reported.
  - f) Indications on the weld line shall not have an aggregate length greater than 0.5 mm (0.02 in) through thickness.

#### **H.7.3.1.5 Add this clause as the following:**

Unless otherwise specified by the purchaser, the following shall be considered:

Prior sectioning (i.e. after testing, scale and deposits removal), the test piece shall be tested using immersion AUT technique, in accordance with NACE TM0284, Appendix A. Unless otherwise agreed with the purchaser, all narrow and wide faces shall be scanned. The CAR of each scanned surfaces shall be calculated and reported.

Additional sectioning shall be performed at the largest AUT indication. Photographs shall be provided in the report, as required in Clause H.7.3.1.4.

Crack sensitivity ratio, crack length ratio and crack thickness ratio shall be reported for each section. The acceptance criteria shall also be applicable to this additional sectioning.

The manufacturer shall submit a detailed HIC test procedure and AUT procedure for the purchaser's acceptance.

#### **H.7.3.1.6 Add this clause as the following:**

Laboratory facilities for testing shall be accepted by the purchaser.

### **H.7.3.2 SSC Test**

#### **H.7.3.2.1 The existing clause shall be deleted and replaced with the following:**

Unless otherwise specified by the purchaser, SSC tests shall be performed in accordance with Clauses H.7.3.2.1.1 to H.7.3.2.1.5.

##### **H.7.3.2.1.1 General**

#### **Add this clause as the following:**

Sulfide stress cracking tests shall be performed using the 4 point bending test method (method B of EFC Publication 16 or NACE TM 0316).

With the exception of the type of specimen (no holes) and the bending method (4-point bending), all the provisions regarding method B of NACE TM0177 shall apply.

The manufacturer shall prepare a fully detailed test procedure proposal based upon this specification and submit it to the purchaser for prior approval.

##### **H.7.3.2.1.2 Test Required**

#### **Add this clause as the following:**

Round bar tensile specimens shall be machined as per ASTM A370 in the base metal and parallel to the pipe axis. The tensile test specimen shall be sampled as close as possible to the place where SSC specimens are sampled.

A tensile test shall subsequently be carried out and the yield strength (0.5 % proof stress) and ultimate



tensile strength shall be recorded.

The lowest yield strength value shall be taken as the reference for the actual yield strength.

The actual yield strength of the base material shall be the reference for calculating the stress level of the SSC tests. The measurement of applied stress shall be made using either electrical strain gauges or the deflection method. If the deflection method is used, it shall be measured using a dial gauge with an accuracy of 0.01 mm (0.0004 in.).

Spare test specimens shall also be cut out and shall be available for additional testing (in case of test failure).

#### **H.7.3.2.1.3 Test Set-up**

##### **Add this clause as the following:**

Unless otherwise specified by the purchaser, test arrangements and loading of specimens shall be in accordance with Appendix 2 of EFC Publication 16: 2009 or ASTM G39 or ISO 7539-2.

The outer and inner rollers shall be made using materials which do not creep when subjected to the sustained loads (e.g. glass and ceramic rods) and avoiding galvanic coupling with the specimen.

Stress applied to specimens shall be adjusted in accordance with H.7.3.2.1.4.

#### **H.7.3.2.1.4 Test Conditions**

##### **Add this clause as the following:**

The test solution shall be the NACE test solution "A" (refer to NACE TM0177).

The manufacturer shall ensure that saturation is obtained within one hour.

Hydrogen sulfide concentration in the solution shall be measured by the iodine titration method at the start and at the end of the test.

The pH of the solution shall be recorded at the start and at the end of the test.

Partial pressure of H<sub>2</sub>S shall be 1 bar.

The test pieces shall be stressed to a 80 % the actual yield strength or 90 % specified minimum yield strength of the pipe, whichever is greater.

**Note 1:** If specified by the purchaser, SSC tests may be performed at 90 % of actual yield strength.

Tests shall have a minimum duration of 30 days (720 hours).

#### **H.7.3.2.1.5 Reporting**

##### **Add this clause as the following:**

At the end of the test, the manufacturer shall provide a test report giving the following information:

- a) Measurement of the actual applied stress (strain gauges, etc.).
- b) Individual results for each specimen tested per set, with photographs and photomicrographs (when applicable).
- c) Type of solution used for the tests. pH of solution at the start and at the end of the test and during the test, for EFC Publication 16 solutions. H<sub>2</sub>S concentration at the start and at the end of the test.
- d) Location and dimensions of specimens.
- e) Mill certificates of materials tested showing full chemical analysis and mechanical properties.
- f) Testing procedure specification.
- g) Conclusions and pertinent explanations (where needed), or concluding information.
- h) Any test failure shall be analyzed by the manufacturer and the cause of failure explained in the report.

**H.7.3.2.2 This clause shall be deleted.****H.7.3.3 Hardness Test****H.7.3.3.1 Add to this clause the following:**

Unless otherwise specified by the purchaser, an additional hardness indentation line is required close to the surface in contact with the sour process fluid, for pipes formed from thermomechanically controlled processed plates and coils. This shall be done using Hv0.5 (500 g), 0.25 mm (0.01 in.) from the surface. Acceptance criteria shall be as per Clause H.4.4. No individual readings shall exceed the acceptance criteria specified in Clause H.4.4.

**Note 1:** If specified by the purchaser, for pipe body tests and parent metal tests, individual hardness readings exceeding the applicable acceptance limit may be not accepted.

**Note 2:** If specified by the purchaser, the hardness indentation shall be as per Figure 14, Figure 15 and Figure 16.

**H.7.5 HIC/SWC Retests****The existing clause shall be deleted and replaced with the following:**

If any HIC/SWC fails during production, the pipe shall be rejected. Retesting shall be as follows, unless otherwise specified by the purchaser:

- a) One retest shall be taken on two different pipes from the same test unit.
- b) Providing both these tests give acceptable results, the test unit shall be considered acceptable.
- c) If either or both pipes fail during retest, the test unit shall be rejected.

The pipes manufactured before and after the discarded test units shall be tested per test units or heats, depending of the result of the root cause analysis (RCA) specified in H.7.3.1.4.

- I) Two pipes from every preceding consecutive test unit/heat shall be tested, until two pipes pass for three consecutive test units/heats.
- II) For pipes manufactured after the discarded test units, two pipes from each subsequent test unit/heat shall be tested until two pipes pass for three consecutive test units/heats.

If applicable, reprocessing shall be as defined in Clause 10.2.11.

**Note 1:** If the root cause analysis (RCA) points to a raw material issue, retest frequency based on heat may be more appropriate.

**H.7.6 SSC Retests****Add this clause as the following:**

If SSC has been specified as a production test (see Table H.3), retesting according to the following procedure and criteria applies, unless otherwise specified by the purchaser:

- a) If any SSC test fails, the pipe shall be rejected and one retest taken on two different pipes from the same test unit.
- b) If both tests pass, the entire test unit may be accepted with the purchaser's review and acceptance.
- c) If the SSC test fails on either or both pipes during retest, all pipes produced prior to the failed SSC test and after the last successful test shall be rejected.

In case of failure, root cause analysis (RCA) shall be performed by means of microstructure/metallographic examination. The affected slab shall be identified and pipe manufactured from the slab, produced before and after the test unit, shall be tested in order to release production. This shall also apply to Clause H.7.5.

---

**Annex K  
(Normative)**

**Nondestructive Inspection for Pipe Ordered for Sour Service, Offshore  
Service, and/or Service Requiring Longitudinal Plastic Strain Capacity**

**K.1 Introduction**

**Add to this clause the following:**

In case of conflict between Annex E and this Annex requirements, the most stringent requirements shall be applied for Pipe Ordered for Sour Service, Offshore Service, and/or Service Requiring Longitudinal Plastic Strain Capacity.

**K.2 General Nondestructive Inspection Requirements and Acceptance Criteria**

**K.2.1.2 The existing clause shall be deleted.**

**K.2.1.3 The existing clause shall be deleted and replaced with the following:**

For pipe with  $t \geq 5.0$  mm (0.197 in.), ultrasonic inspection with automated/semiautomated systems in accordance with ISO 10893-8 or by manual methods, as specified in Annex A of ISO 10893-8:2011, shall be used to verify that at least  $[3.5t + 25$  mm (0.98 in.)] or 100 mm (3.94 in.), whichever is greater, wide zone at each pipe end is free of such laminar defects. Pipe end UT shall be undertaken from the outside surface and be inspected before beveling.

**Note 1:** If specified pipe end UT inspection after weld beveling by the purchaser, it shall be undertaken from the pipe internal surface following by MT test (with a suitable technique for laminar imperfection e.g. radially through wall thickness) to find laminar defect on both bevel faces of pipes in accordance with ISO 10893-5 or ASTM E709; Bevel faces shall be free of indications.

**K.2.1.4 The existing clause shall be deleted and replaced with the following:**

If specified by the purchaser, MT of pipe end face/bevel shall be carried out associated with UT inspection for the detection of laminar imperfections, in accordance with ISO 10893-5 or ASTM E709. The end face shall be free of indications.

**K.2.2 Suspect Pipe**

**K.2.2.4 The existing clause shall be deleted and replaced with the following:**

When dressing is carried out, complete removal of defects shall be verified by local visual inspection and by an NDT method in accordance with Clause C.2.3.

**K.3 Nondestructive Inspection of SMLS Pipe**

**K.3.1 The existing title and clause shall be deleted and replaced with the following:**

**K.3.1 Ultrasonic Inspection for Longitudinal and Transverse Imperfections**

SMLS pipe shall be full-body (100% of full length) ultrasonically inspected for the detection of longitudinal and transverse imperfections in accordance with ISO 10893-10 or ASTM E213. The acceptance limits for such inspection shall be in accordance with ISO 10893-10, acceptance level U2/C.

---

**K.3.2 Laminar Imperfections in the Pipe Body****K.3.2.1 The existing clause shall be deleted and replaced with the following:**

For sour service, individual laminations and/or lamination densities exceeding the acceptance limits for sour service given in Table K.1 shall be classified as defects. Compliance with such requirements shall be verified by ultrasonic inspection in accordance with ISO 10893-8:2011 (except 4.2), ASTM A435, or ASTM A578. Unless otherwise specified by the purchaser, the coverage during automatic inspection shall be 100 % of the pipe surface.

**K.3.2.2 The existing clause shall be deleted and replaced with the following:**

For offshore service and service requiring longitudinal plastic strain capacity, individual laminations and/or lamination densities exceeding the acceptance limits given in Table K.1 shall be classified as defects. Compliance with such requirements shall be verified by ultrasonic inspection in accordance with ISO 10893-8:2011 (except 4.2), ASTM A435, or ASTM A578. Unless otherwise specified by the purchaser, the coverage during automatic inspection shall be 100 % of the pipe surface.

**K.3.3 Ultrasonic Thickness Measurements****The existing clause shall be deleted and replaced with the following:**

For all pipe, ultrasonic thickness measurements shall be carried out at least as Annex E, Clause E.11.

**Note 1:** For ultrasonic thickness measurements of seamless pipes, the Scanning coverage shall be 100 % of the area of the pipe, unless otherwise specified by the purchaser.

**Table K.1 – Acceptance Criteria for Laminar Imperfections**

Service condition	Maximum individual imperfection		Minimum imperfection size considered			Maximum population density <sup>a</sup>
	Area mm <sup>2</sup> (in <sup>2</sup> )	Length mm (in)	Area mm <sup>2</sup> (in <sup>2</sup> )	Length mm(in)	Width mm(in)	
<b>Pipe body (or strip(coil)/plate body)</b>						
Offshore and longitudinal plastic strain capacity	1000(1.6)	Not specified	300 (0.5)	35 (1.4)	8 (0.3)	10 [per 1,0 m (3.3 ft) × 1,0m (3.3 ft) square] <sup>b</sup>
Sour	100 (0.16)		30 (0.05)	5 (0.2)	5 (0.2)	5 [per 500 mm(1.6 ft) × 500 mm (1.6ft) square ] <sup>c</sup>
<b>Strip(coil)/plate edges or areas adjacent to the weld seam <sup>d</sup></b>						
Sour, offshore, or longitudinal plastic strain capacity	100 (0.16)	20(0.8)	-	10(0.4)	-	3 [per 1,0m (3.3 ft)length]
<p><b>Note 1.</b> For an imperfection to be larger than the minimum imperfection size, the minimum area, minimum length and minimum width given for the pipe body (or strip(coil)/plate body) all have to be exceeded.</p> <p><b>Note 2.</b> For the purpose of determining the extent of suspect area, adjacent suspect areas separated by less than the smaller two minor axes of the areas shall be considered one area.</p>						
<p>a. Number of imperfection smaller than the maximum and greater than the minimum imperfection size.</p> <p>b. For pipe with D &lt; 323,9 mm (12.375 in ) or strip(Coil)/plate widths less than 1 000 mm (39.4 in ) , the maximum population density is referred to 1,0 m<sup>2</sup> (10.8 ft<sup>2</sup>).</p> <p>c. For pipe with D &lt; 168,3mm (6.625 in) or strip(Coil)/plate widths less than 500 mm (19.7 in), the maximum population density is referred to 0,25 m<sup>2</sup> (2.7 ft<sup>2</sup>).</p> <p>d. The maximum imperfection area of edges is the product of the maximum imperfection length, where length is the dimension parallel to the material edge and the transverse dimension, An imperfection is considered to be larger than the maximum imperfection size if either the length or the transverse dimension is exceeded.</p>						

**K.4 Nondestructive Inspection of HFW Pipe**

**K.4.1 Nondestructive Inspection of the Weld Seam**

**The existing clause shall be deleted and replaced with the following:**

The full length of the weld seam shall be ultrasonically inspected for the detection of longitudinal imperfections, with the acceptance limits being in accordance with one of the following, unless otherwise specified by the purchaser:

- a) ISO 10893-11 acceptance level U2/U2H.
- b) ISO 10893-10 acceptance level U2; (If specified by the purchaser, acceptance level U2).
- c) ASTM E273.

**Note 1:** Relevant sections of Annex E shall be considered.

#### **K.4.2 Laminar Imperfections in the Pipe Body**

**The existing clause shall be deleted and replaced with the following:**

The pipe or strip (coil)/plate body shall be ultrasonically inspected for the detection of laminar imperfections in accordance with ISO 10893-8:2011 (except Clause 4.2) or ISO 10893-9, respectively, to acceptance limits for the relevant application as given in Table K.1. Unless otherwise specified by the purchaser, the coverage during automatic inspection shall be 100% of the pipe surface; (Also consider Annex E, Clause E.8).

#### **K.4.3 Laminar imperfections on the strip/plate edges or areas adjacent to the weld seam**

**The existing clause shall be deleted and replaced with the following:**

The strip(coil)/plate edges or the areas adjacent to the weld seam shall be ultrasonically inspected at least over a width of at least  $[3.5t + 25 \text{ mm (0.98 in.)}]$  or 50 mm (3.94 in.), whichever is greater, for the detection of laminar imperfections, in accordance with ISO 10893-9 or ISO 10893-8, respectively, to the acceptance limits as given in Table K.1 for strip/plate edges or areas adjacent to the weld seam; (Also consider Annex E, Clause E.9).

#### **K.4.4 Supplementary non-destructive inspection**

**The existing clause shall be deleted and replaced with the following:**

Unless otherwise specified by the purchaser, the pipe body of HFW pipe shall be inspected for the detection of longitudinal imperfections using the ultrasonic method in accordance with ISO 10893-10, acceptance level U2/C (if specified by the purchaser, acceptance level U3/C) or ASTM E213.

**Note 1:** If specified by the purchaser, the flux-leakage method in accordance with ISO 10893-3 acceptance level F2 (if specified by the purchaser, acceptance level F3) or ASTM E570 may be used.

#### **K.5 Nondestructive Inspection of SAW Pipe**

##### **K.5.1 Ultrasonic Inspection for Longitudinal and Transverse Imperfections in Seam Welds**

**K.5.1.1 The existing first paragraph of item c) shall be deleted and replaced with the following:**

c) Manufacturer shall use acceptance level U2 internal and external notches, laying at right angles to, and centered over, the weld seam. In this case, both internal and external weld reinforcements shall be ground flush to match the pipe contour in the immediate area and on both sides of the reference notches. The notches shall be sufficiently separated from each other in the longitudinal direction and from any remaining reinforcement, to give clearly identifiable separate ultrasonic signal responses. The full signal amplitude from each of such notches shall be used to set the trigger/alarm level of the equipment.

##### **K.5.2 Laminar Imperfections in the Pipe Body and on the Strip/Plate Edges**

**K.5.2.1 The existing clause shall be deleted and replaced with the following:**

The pipe or strip(coil)/plate body shall be ultrasonically inspected for the detection of laminar imperfections in accordance with ISO 10893-9 to acceptance limits for the relevant service condition as given in Table K.1, and unless otherwise specified by the purchaser, with a coverage 100% of pipe or strip(coil)/plate body; (Also consider Annex E, Clause E.8).

**K.5.2.2 The existing clause shall be deleted and replaced with the following:**

The strip(coil)/plate edges shall be ultrasonically inspected at least over a width of at least  $[3.5t + 25 \text{ mm (0.98 in.)}]$  or 50 mm (3.94 in.), whichever is greater, for the detection of laminar imperfections in accordance with ISO 10893-9 to acceptance limits as given in Table K.1 for strip(coil)/plate edges or areas adjacent to the weld seam; (Also consider Annex E, Clause E.9).

---

**K.5.3 Nondestructive Inspection of the Weld Seam at the Pipe Ends/Repaired Areas****The existing clause shall be deleted and replaced with the following:**

The length of weld seam at pipe ends that cannot be inspected by the automatic ultrasonic equipment and repaired areas of the weld seam (see Clause C.4) shall be subjected to the following:

- a) For the detection of longitudinal imperfections, manual or semi-automatic ultrasonic inspection using the same inspection sensitivity and inspection parameters as is specified in Clause K.5.1.1 and radiographic inspection in accordance with Clause E.4.
- b) For the detection of transverse imperfections, a manual/semi-automatic ultrasonic inspection using the same inspection sensitivity and parameters as is specified in Clause K.5.1.1 and radiographic inspection in accordance with Clause E.4.

For manual ultrasonic inspection, the scanning speed should be  $\leq 150$  mm/s (6 in./s).

**K.5.5 Laminar Imperfections on the Plate/Coil Edges or Areas Adjacent to the Weld Seam****Add this clause as the following:**

The strip(coil)/plate edges or the areas adjacent to the weld seam shall be ultrasonically inspected at least over a width of at least  $[3.5t + 25 \text{ mm (0.98 in.)}]$  or 50 mm (3.94 in.), whichever is greater, for the detection of laminar imperfections, in accordance with ISO 10893-9 or ISO 10893-8, respectively, to the acceptance limits as given in Table K.1 for strip(coil)/plate edges or areas adjacent to the weld seam; (Also consider Annex E, Clause E.9).

**K.6 Plate Surface Inspection for Hard Surface Layer****Add this clause as the following:**

If specified by the purchaser:

The surface of thermomechanically rolled plates which will be in contact with the sour service, shall be inspected for the detection of possible surface hard layers.

The NDT procedure, verification of the NDT technique and procedure qualification shall be subject to the purchaser's acceptance. The equipment (e.g. eddy current technique) shall be subject to the purchaser's approval.

Unless otherwise agreed, any blind zone shall be inspected by portable hardness tester following a grid pattern. Grid dimensions are to be agreed upon at bid stage. Alternatively, blind zones shall be cropped.

The manufacturer shall submit details of the inspection technique employed, including inspection and evaluation of blind zones, to the purchaser.

A hardness increase due to cold forming and ageing, if applicable, shall be considered. This hardness increase shall be documented by the manufacturer and may be used to define the plate maximum acceptable hardness value. This surface hardness value measured on the plate surface shall not exceed 220HV or other acceptance criteria with COMPANY's approval.

---

**Appendix 1  
(Informative)**

**Welding Consumables**

**AP1.1 General**

The manufacturer's procedures concerning storing, handling, drying, recycling and traceability of consumables is subject to the purchaser's review and acceptance. The manufacturer shall provide evidence of long and successful use of the proposed combination of welding consumables on similar applications, to the satisfaction of the purchaser.

Welding consumables shall be stored and handled in accordance with the supplier's written recommendations.

The welding consumables shall be procured according to AWS A5.01 or ASME BPVC Section II Part C SFA A5.01 and be supplied by a supplier accepted by the purchaser.

The level of testing shall be in accordance with Schedule I as specified in AWS A5.01.

Unless otherwise specified in the MPS, all welding consumables shall be individually marked and supplied with an inspection certificate type 3.1 according to EN 10204, obtained for the same batch.

Deposited weld metal shall not have diffusible hydrogen content higher than 5 ml per 100 g weld metal under production conditions, tested in accordance with ISO 3690. The hydrogen content test shall be done during the packing and the actual value shall be specified in the certified material test report.

If specified in the MPS, welding consumables and procedures that produce a weld deposit containing more than 1 % mass fraction nickel are not acceptable.

Weld deposits shall be in compliance with ISO 15156 for welding consumables for SAW pipes ordered for sour service applications.

**AP1.2 Consumables for GMAW**

The solid electrode shall conform to the requirements of either AWS A5.18 or AWS A5.28 and produced according to Lot Class S3 of AWS A5.01.

The gas shielding shall conform to the requirements of AWS A5.32.

**AP1.3 Consumables for SAW**

The SAW consumables shall conform to the requirements of either AWS A5.17 or AWS A5.23 and produced according to Lot Class S3 and Lot Class F2 of AWS A5.01 for solid electrode and flux, respectively.

The manufacturer shall issue a dedicated procedure for flux management. This procedure shall cover all steps from flux purchasing to the "ready-to-use" step (welding heads).

This procedure shall be submitted to the purchaser for review.

**AP1.3.1 Procurement of flux**

At the time of packing the flux, the diffusible hydrogen content in the SAW weld deposit shall be lower than 5 ml/100 g of weld deposit, taken from a sample of the batch of flux.

Flux grain size shall be checked per batch when the flux is first received. The recorded grain size shall comply with the recommendation of the flux supplier. Should any deviation be recorded, the flux shall be rejected.



Acceptable packing shall be:

- metallic / stiff plastic drums with a rubber gasket for top tightness;
- double polymer top welded bags;
- PEHD-aluminium-PEHD top welded bags.

The packing shall be designed to guarantee no significant humidity absorption during storage for a minimum of one year.

### **AP1.3.2 Diffusible Hydrogen, Moisture Content Test**

Diffusible hydrogen assessment may be done through moisture content measurement, when evidence of correlation for the flux intended to be used, can be provided by the flux supplier (previously established data is acceptable).

This correlation curve shall be based on previous comparative tests of diffusible hydrogen versus flux moisture content.

The maximum moisture content shall be 0.03 % unless a higher figure can be justified via the correlation curves.

#### **AP1.3.2.1 Test Condition**

The moisture content shall be measured as per AWS A4.4M by the "Karl Fisher" method, or by using equivalent equipment subject to the purchaser's acceptance.

For diffusible hydrogen testing or for moisture measurement, neither pre-drying nor any pre-heating of the flux sample shall be carried out before testing, regardless of applicable standard guidance.

The moisture measurement test shall be carried out at 982 °C (1800 °F) minimum. The carrier gas shall contain 10 % minimum of oxygen.

#### **AP1.3.2.2 Test Results**

Results of diffusible hydrogen or moisture measurement shall be reported on the 3.1 flux certificate for each batch. The testing conditions as per this appendix shall be confirmed on the certificate.

#### **AP1.3.3 Flux Storage**

Flux shall be stored in a room with controlled hygrometry and temperature.

The resulting relative hygrometry and temperature values shall be permanently maintained such that the resulting absolute hygrometry is as per the supplier's recommendation.

The maximum duration of storage shall be one year after the date of packing. After one year of storage, a spot check of the diffusible hydrogen / moisture content shall be required.

Flux that has been wet or damp shall not be used.

#### **AP1.3.4 Flux Handling and Transfer System**

Drums/bags shall be checked before using the flux and be undamaged.

All flux shall be dried before use and poured in the welding machine hopper. The temperature of the hopper shall be maintained between 120 °C (248 °F) and 150 °C (302 °F).

Flux feeding from the hopper shall be by gravity. If pressurized air is used for flux conveying, the air shall be dried and made oil-free.

The manufacturer shall explain the flux management philosophy in case of an interruption or pause in welding.

---

Unless the manufacturer can justify otherwise, in case of welding interruption:

- a) of more than two hours, the system of feeding downstream of the hoppers shall be drained off before recommencing welding;
- b) of more than 12 hours, the remaining flux stored in the hoppers shall be scrapped.

**Note:** Flux is often stored in an intermediate oven at 150 °C (302 °F) to avoid a reduction of the flux temperature in the welding machine hopper during charging of the new flux.

### **AP1.3.5 Flux Recycling**

#### **AP1.3.5.1 Flux Recycling**

When recycling flux, the manufacturer shall demonstrate that the mill has an appropriate flux recycling system:

- a) As a minimum, the flux recovery system shall be equipped with vacuum suction to collect the excess unfused flux from the weld seam.
- b) The recovered flux shall be processed with sieving and a magnetic separator.
- c) The size distribution of recovered flux shall be within a tolerance  $\pm 5$  % of the fresh batch.
- d) The frequency of flux size testing shall be aligned with the moisture content check.
- e) The use of crushed or recycled slag, or blending crushed or recycled slag with fresh flux is not permitted

#### **AP1.3.5.2 Moisture Content Check**

In case of flux recycling, the manufacturer shall demonstrate that the flux management system will guarantee dry flux at the welding point:

- a) Flux shall be sampled at the welding point and checked at the start of production and then once per shift for both inside and outside welding. All welding lines shall be sequentially tested.
- b) The inspector may impose the timing for sampling.
- c) The test procedure and results shall comply with AP1.3.2.
- d) The procedure shall include a scheme of flux management and shall specify the temperature of the ovens used for re-drying.

### **AP1.4 Consumables for SMAW**

The covered electrodes shall conform to the requirements of either AWS A5.1 or AWS A5.5, produced according to Lot Class C5 of AWS A5.01 and shall be supplied in hermetically sealed containers. Cellulose coated electrodes shall not be used.

---

**Appendix 2**  
**(Informative)**  
**Weldability Test**

**AP2.1 Introduction**

The intent of the weldability test is to verify acceptable properties in the girth weld HAZ. The manufacturer should note that the weldability tests are acceptance tests for the pipes, and that pipes cannot be accepted until these tests have been successfully completed.

Weldability tests shall be performed by the pipe manufacturer or by an accepted supplier under their responsibility.

Where the purchaser allows data from previous weldability trials in lieu of testing, material used in the previous weldability trials shall be identical in grade and manufacturing procedure to the pipe to be supplied, and be of similar diameter, wall thickness and chemical composition (within the limits of applicable chemical composition and associated tolerances).

**AP2.2 Material for Weldability Test**

The pipe material shall be qualified in accordance with the manufacturing procedure qualification (see Annex B) and within the limits specified (see B.5.).

Weldability tests shall be conducted for each steel grade, pipe size and steel source on pipes produced at an early production stage.

Pipe size grouping of dimensions may be allowed, subject to the purchaser's approval, however as a minimum, those with the greatest wall thickness shall be tested.

The material shall be taken from finished production pipes.

Pipes shall be selected from the high end of the chemical composition range, e.g. no less than 0.02 % less than the maximum carbon content,  $CE_{IIW}$ ,  $CE_{Pcm}$ .

The purchaser shall accept the heat analysis of steel or pipes to be used for the weldability tests.

**AP2.3 Welding Procedure Specification (WPS)**

Prior to welding, the manufacturer shall submit a pWPS including as a minimum:

- a) details of welding consumables, type of process, welding parameters, etc.;
- b) proposals on the pipe ring dimensions (length) so as to represent realistic welding conditions;
- c) full details of weld bevel geometries. The proposed groove profile shall be such that the welding will result in a straight HAZ on one side of the bevel (i.e. half-V bevel or narrow gap bevel shall be used);
- d) the welds shall be single sided from the outer surface of pipe;
- e) welding positions, heat input range;
- f) tests rings for weldability tests to be sampled from pipe ends.

No welding test shall be carried out until the manufacturer's proposals have been accepted by the purchaser.

**AP2.3.1 Test Welds**

At least one full butt weld shall be produced for each trial.

The welding processes for weldability tests shall be proposed by the manufacturer in accordance with the method for pipe laying (e.g. P-GTAW, P-GMAW, m-GMAW, STT, CMT, SMAW and SAW).

Test coupons shall be prepared with a single V-groove. Test coupons shall have one side with 0° bevel angle. The tests shall be carried out with two welding heat inputs as follows:

a) low welding heat inputs ( $0.45 \text{ KJ/mm} \leq \text{HI} \leq 0.75 \text{ KJ/mm}$ ) with a maximum preheat temperature of 50 °C (122 °F) and an inter-pass temperature not exceeding 250 °C (482 °F);

b) high welding heat inputs ( $1.5 \text{ KJ/mm} \leq \text{HI} \leq 3 \text{ KJ/mm}$ ) with a preheat temperature and inter-pass temperature not lower than 250 °C (482 °F).

The HAZ shall be considered sufficiently straight when scribed marks for the machining of fracture toughness specimen notches sample at least 75 % of the scribe length in the central two thirds of the specimen thickness within 0.5 mm (0.02 in.) of the fusion line.

**Note 1:** The 75 % of the scribe length need not be continuous. The fusion line shall be considered part of the weld metal and not be included in the determination of % HAZ sampled.

The time lapse between the root and hot pass shall be 15 minutes without maintaining preheating during that time.

**Note 2:** Weld bead placement techniques should be utilized such that within the central 60 % of the section thickness, 25 % of the weld metal adjacent to the fusion line on the square edge side of the weld groove is unrefined-columnar weld metal.

### AP2.3.2 Testing and Inspection

#### AP2.3.2.1 Nondestructive Testing

The test weld shall be inspected by visual, magnetic particle and UT or X-ray radiography testing.

The weld shall satisfy the acceptance criteria of the specific project fabrication code prior to being sent for sampling.

The project fabrication code shall be specified in the MPS.

#### AP2.3.2.2 Mechanical Testing

The test specimen failing due to welding defects shall be declared as invalid and retesting is permitted upon the purchaser's acceptance.

##### AP2.3.2.2.1 Tensile Testing

A cross weld tensile test shall be carried out for information.

**Note:** A failure located in the weld metal shall not be considered relevant. The intent of the test is to gather information on HAZ performance.

##### AP2.3.2.2.2 Charpy Testing

For welding in position 5G, a set of specimens shall be cut at the 12 o'clock, 3 o'clock and 6 o'clock positions, transverse to the weld direction. For other welding position (i.e. 1G or 2G), a sample of specimens shall be taken from two opposite locations.

Each set shall consist of three specimens.

The notches shall be located at mid-thickness of the welded side with 0° bevel as per Figure AP2.1.

Additionally, for welded pipes, a set of Charpy specimens shall be taken from the intersection of the longitudinal and circumferential weld seam and the notch location shall be extended into the longitudinal seam side.

The impact test temperature and acceptance criteria shall be as defined in 9.8 or the relevant annex/appendix. Alternative test conditions and acceptance criteria may be specified in the MPS.

If specified in the MPS, a transition curve shall be performed for each test location.

**AP2.3.2.2.3 CTOD Test**

CTOD specimens shall be taken from both low and high welding heat input test coupons.

A set of specimens shall be cut at the 12 o'clock and 6 o'clock positions for the 5G welding position and shall be located at mid-thickness. For each set, three specimens shall be cut and tested. For other welding positions (i.e. 1G or 2G), a sample of CTOD specimens shall be taken from one location only.

SENB B\*2B specimens shall be used. The notches shall be located on the welded side with 0° bevel as follows:

- a) in the coarse grain HAZ (CGHAZ) – to be determined by metallography;
- b) at 2 mm (0.08 in.) from the fusion line – to be determined by metallography.

Sectioning of CTOD samples should be made following testing, to ensure sampling of the required areas. Pre and post-testing macrographs shall be supplied to show that sampling requirements have been met.

CTOD testing shall be carried out in accordance with ISO 15653 and ISO 12135.

The CTOD test temperature and acceptance criteria shall be defined in the relevant annex/appendix or in the MPS.

**AP2.3.2.2.4 Macrography and Vickers Hardness Survey**

Three specimens shall be extracted, one at each of the 12 o'clock, 3 o'clock and 6 o'clock positions for the 5G welding position.

For other welding positions (i.e. 1G or 2G), a sample of macrography specimens shall be taken from two locations:

- a) 180° apart for pipe; and
- b) a minimum distance of 300 mm (12 in.) apart for plate.

For the above macrographic cross-sections, an HV10 hardness survey shall be conducted as per Figure AP2.2.

If not specified in the MPS, the acceptance criteria shall be as per the applicable annex/appendix.

**AP2.4 Reporting**

Following completion of the test program, the results and a final report from the manufacturer shall be submitted to the purchaser.

The final report shall include, as a minimum, the following:

- a) welding procedure specifications;
- b) procedure qualification records;
- c) mill certificates of pipe materials used;
- d) NDT and mechanical test results (including any failures);
- e) any other testing agreed with the purchaser;
- f) any necessary photographs, macrographs and micrographs (if any); and
- g) the interpretation of the results and the conclusions of the manufacturer, including the recommendations for welding the pipes at the installation site.

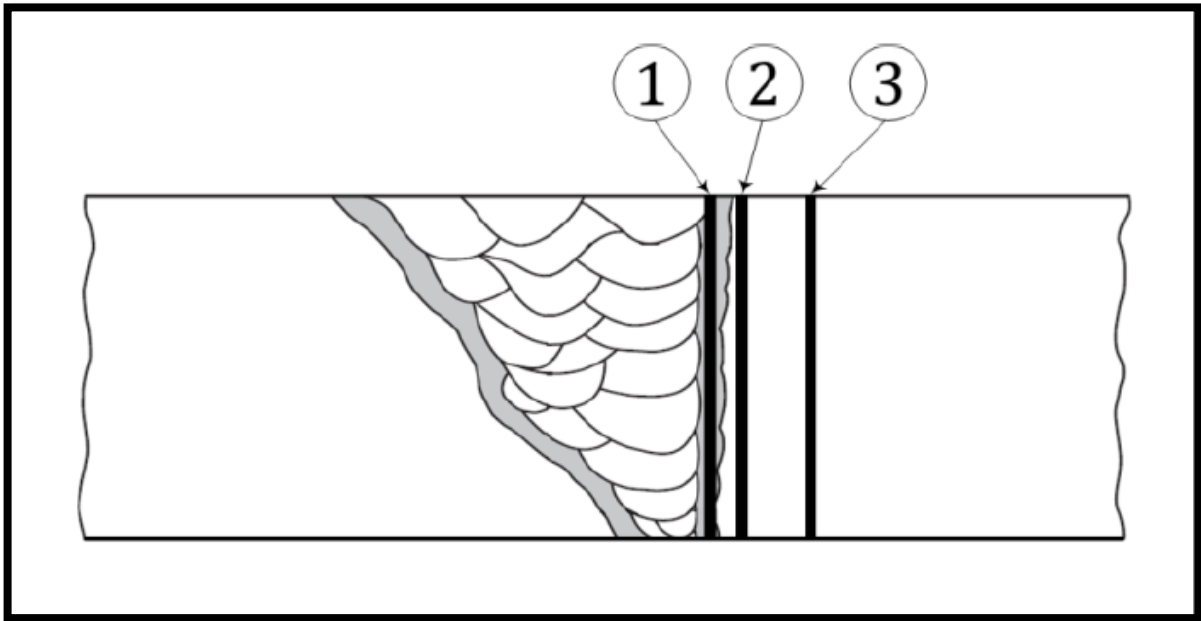

**Key**

- ① In the Coarse Grain HAZ (CGHAZ) – to be determined by metallography
- ② At 2 mm from the Fusion Line
- ③ At 5 mm from the Fusion Line

**Figure AP2.1 – Charpy Testing Locations**

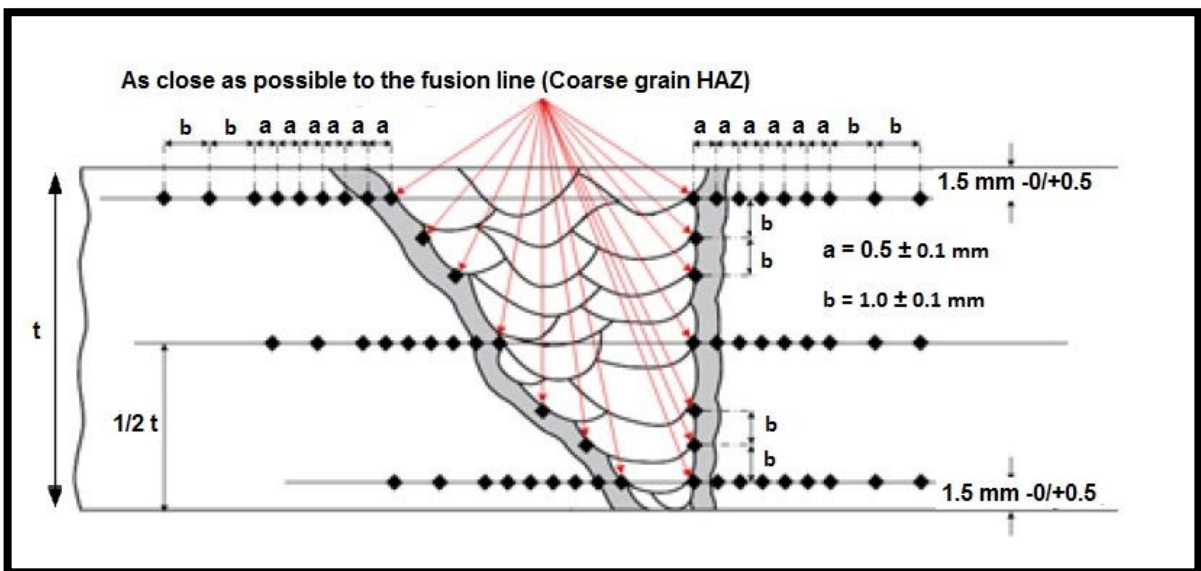

**Figure AP2.2 – Hardness Indents Location**

---

**Appendix 3  
(Informative)**

**Qualification of NDT at Plate/Coil and Pipe Mills**

Qualification shall be subject to demonstration of the capability of the mill to satisfy the requirements of this specification, and all standards referenced herein.

The qualification shall remain valid for a period of four years unless there is a change to the equipment, including structural components, software or hardware.

The purchaser may require repeating the qualification for a specific project. This shall be specified in the MPS.

The process for the qualification of pipe mill NDT equipment and practices shall be as follows.

**AP3.1 Prior to the Qualification Audit**

The mill shall submit the following information to the purchaser for review and agreement prior to the audit:

**a)** Scope of the qualification required, as follows:

- 1) Renewal of existing scope of qualification, extension to scope or new qualification;
- 2) Service: whether “conventional”, sour or offshore or multiple services, the audit shall be based on the most stringent requirement, based on the mill’s capability;
- 3) Pipe types (manufacturing methods e.g. SAW, HFW, SMLS), materials, grades;
- 4) For each pipe type: ranges of pipe diameter and thickness for which qualification is sought;
- 5) For plate/coil: materials, grades, and ranges of length, width and thickness;
- 6) Applicable NDT methods, techniques and documented threshold settings.

**b)** Written procedures for NDT including applicable methods, compliant with Appendix 6 and applicable to the scope (and for UT and EMI: reference standards) of the audit;

**c)** Design of UT and/or EMI reference standards, compliant with E.5.2;

**d)** Report of visual and dimensional inspection for UT and EMI reference standards, demonstrating compliance with AP3.1 c);

**e)** Detailed description of the equipment design and any capability studies that the mill may have performed on the equipment.

**AP3.2 NDT Method-specific Requirements During the Qualification Audit**

**AP3.2.1 General Requirements**

The qualification audit shall include (but not necessarily be limited to):

**a)** Practical demonstration of each applicable NDT method and technique, performed on welds, pipes, plates/coils (as applicable).

**b)** Calibrations, control checks and maintenance;

**c)** Qualification and certification of NDT personnel; and

**d)** Elements of the quality system/business management system related to NDT.

### AP3.2.2 Practical Demonstrations

Inspection parameters shall be qualified on an individual basis. This means that for systems using more than one configuration, each transducer array shall be qualified individually and documented in a scan plan and standard operating procedures.

For HFW mills that perform full-body AUT, the coil edge AUT system is exempt from qualification.

#### AP3.2.2.1 AUT of Plate/Coil

The practical demonstration shall be carried out on one or more reference standards (as agreed with the purchaser) covering the manufacturing thickness range capability and shall include:

- a) Equipment set-up;
- b) Static and dynamic standardization;
- c) Gate positions for defects and coupling, S/N ratio;
- d) Extent of coverage;
- e) Detection of all required reference reflectors;
- f) Repeatability trial; and
- g) Documented threshold settings.

In addition, at least one production plate shall be scanned at production settings to demonstrate achievement of 100 % scanning coverage.

##### AP.3.2.2.1.1 Repeatability trials

- a) The repeatability trial shall be carried out dynamically, using the same conveyor assembly and at the maximum scanning speed(s) (travel and/or cross-head) to be used during production;
- b) Indications from all reference reflectors shall be set at a suitable amplitude to enable recording and subsequent height measurement, typically 80 % FSH  $\pm$  5% (i.e. where an AUT system can only measure amplitudes up to 100 % FSH, any indication greater than 100 % shall be invalid);
- c) Ten test runs shall be carried out;
- d) The results of a repeatability trial shall be considered acceptable when no reference reflector indication amplitude deviates from the average value by more than  $\pm$ 25 % (or equivalent dB tolerance(s) as determined by the purchaser).
- e) The following data shall be recorded:
  - 1) Written procedure;
  - 2) Reference standard details and dimensions;
  - 3) Equipment used, including probe types, frequencies and dimensions;
  - 4) C-scan record, either paper or digital – as applicable;
  - 5) For each channel: the probes used, scanning direction, reference reflector identities and locations, indication amplitudes (digitally recorded);
  - 6) Indication amplitudes for all reference reflectors shall be recorded as percentage of screen height or as percentage chart height (as applicable), or decibels, using an automated digital method such as a digital export feature, to at least one decimal point (e.g. 81.6 %, not rounded up to 82 %); and
  - 7) Indication amplitudes for all channels and all reference reflectors shall be entered into a spreadsheet supplied by the auditor for the calculation of the average values and the minimum and maximum deviations from the average values.



**AP3.2.2.2 AUT of HFW, SAW and SMLS Pipe**

The practical demonstration shall be carried out on one or more reference covering the manufacturing thickness and diameter range capability and shall include:

- a) Equipment set-up;
- b) Static (if practicable) and dynamic standardization;
- c) Gate positions for defects and coupling, S/N ratio;
- d) Detection of all reference reflectors (as per Annex E Table E.7.1, Table E.7.2 and Table E.7.3);
- e) Repeatability trial;
- f) Extent of coverage;
- g) Accuracy and consistency of seam tracking system;
- h) Documented threshold settings.

**AP3.2.2.2.1**

The number and dimensions of reference standard/pipe shall be determined as follows:

- a) For wall thickness  $\leq 12$  mm (0.47 in.): one reference standard having the lowest wall thickness and smallest diameter to be qualified;
- b) For wall thickness  $> 12$  mm (0.47 in.): one reference standard having the highest wall thickness and largest diameter to be qualified.

**AP3.2.2.2.2**

For the repeatability trial, the following shall apply:

- a) The repeatability trial shall be carried out dynamically, using the same conveyor assembly and at the maximum scanning speeds (travel and/or cross-head) to be used during production.
- b) Indications from all reference reflectors shall be set at a suitable amplitude to enable recording and subsequent height measurement, typically 80 % FSH  $\pm 5$  % (i.e. where an AUT system can only measure amplitudes up to 100 % FSH, any indication greater than 100 % shall be invalid)
- c) Ten uninterrupted test runs, in the forward direction, without any adjustment of equipment or settings. Any interruption or adjustment shall invalidate the results.
- d) When specified in the MPS by the purchaser, ten uninterrupted test runs, in the reverse direction (after turning the reference standard end-to-end), without any adjustment of equipment or settings. Any interruption or adjustment shall invalidate the results.
- e) For equipment with rotating head assemblies, 20 runs shall be completed in total, consisting of five runs at each pipe angular position (0°, 90°, 180° and 270°), the pipe being rotated after each series of five runs.
- f) The results of a repeatability trial shall be considered acceptable when no reference reflector indication amplitude deviates from the average value by more than  $\pm 25$  % (or equivalent dB tolerances as determined by the purchaser).
- g) The following data shall be recorded:
  - 1) Written procedure;
  - 2) Reference standard details and dimensions;
  - 3) Equipment used, including probe types, frequencies and dimensions;
  - 4) Chart record, either paper or digital – as applicable;
  - 5) For each scan number: the channel, probes used, scanning direction, reference reflector identities and locations, indication amplitudes (digitally recorded);

6) Indication amplitudes for all reference reflectors shall be recorded as percentage of screen height or as percentage chart height (as applicable), or decibels, using an automated digital method such as a digital export feature, to at least one decimal point (e.g. 81.6 %, not rounded up to 82 %); and

7) Indication amplitudes for all channels and all reference reflectors shall be entered into a spreadsheet supplied by the auditor for the calculation of the average values and the minimum and maximum deviations from the average values.

#### **AP3.2.2.3 EMI of Welded or SMLS Pipe**

The practical demonstration shall be carried out on one or more reference standards (as agreed with the purchaser) and shall include:

- a) Equipment set-up;
- b) Static (if practicable) and dynamic standardization;
- c) Gate positions for defects, S/N ratio;
- d) Detection of all reference reflectors;
- e) Extent of coverage;
- f) Repeatability trial;
- g) Application to one or more production pipes, or suitable substitute, to be determined by the purchaser;
- h) Documented threshold settings.

##### **AP3.2.2.3.1**

The number and dimensions of reference standard/pipe shall be determined as follows:

- One reference standard representative of the diameter and thickness range to be qualified, as agreed with the purchaser.

##### **AP3.2.2.3.2**

For the repeatability trial, the following apply in one direction of the reference standard:

- a) Carried out dynamically, using the same conveyor assembly and at the maximum scanning speed(s) (travel and/or cross-head) to be used during production.
- b) Indications from all reference reflectors shall be set at a suitable amplitude to enable recording and subsequent height measurement, typically 80 % FSH  $\pm$ 5 % (i.e. where an EMI system can only measure amplitudes up to 100 % FSH, any indication greater than 100 % shall be invalid).
- c) Ten uninterrupted test runs, without any adjustment of equipment or settings. Any interruption or adjustment shall invalidate the results.
- d) The results of a repeatability trial shall be considered acceptable when no reference reflector indication amplitude deviates from the average value by more than  $\pm$ 25 % (or equivalent dB tolerances).
- e) The following data shall be recorded:
  - 1) Written procedure;
  - 2) Reference standard details and dimensions;
  - 3) Equipment used, including probe types, frequencies and dimensions;
  - 4) Chart record, either paper or digital – as applicable;

- 5) For each scan number: the channel, probes used, scanning direction, reference reflector identities and locations, indication amplitudes (digitally recorded);
- 6) Indication amplitudes for all reference reflectors shall be recorded as percentage of screen height or as percentage of chart height (as applicable), using a consistent method, to at least one decimal point (e.g. 81.6 %, not rounded up to 82 %); and
- 7) Indication amplitudes for all channels and all reference reflectors shall be entered into a spreadsheet supplied by the auditor for the calculation of the average values and the minimum and maximum deviations from the average values.

**Appendix 4  
(Informative)**

**Procedure Requirements for NDT**

The manufacturer shall provide a procedure for each NDT technique, describing the inspection equipment and processes to be applied. Multiple NDT techniques shall not be combined within one procedure. The procedures shall contain as a minimum, the details stated in the tables included in this appendix and shall be submitted to the purchaser in English, for review and acceptance prior to qualification or requalification of the mill NDT or production NDT.

**Table AP4.1 – Ultrasonic Testing (UT)**

<b>Scope (application)</b>	Product from (e.g. plate, pipe, pipe end, weld, etc.)
	Material grade and specification
	Dimensions (plate/strip (coil): length, width, thickness: pipe: length, diameter, thickness)
	Coverage required: coverage limits
	Weld process (as applicable)
	Weld preparation (drawing showing weld preparation dimensions and angles)
	Reference to this specification and related standards
<b>Personnel</b>	Qualification requirements
	Performance demonstration – if required
<b>Stage of manufacture</b>	Stage at which UT is to be performed e.g. for longitudinally welded pipe seams – after hydrotest
<b>Surface Condition</b>	Condition and surface preparation of scanning surfaces
	Profile of scanning surface
<b>Inspection techniques</b>	Whether automated. Semi- automated or normal
	Contact-, gap- or immersion-scanning
<b>Equipment</b>	Instrument/System: manufacturer type and designation. Number of channels. Computerized programmed identification and revision.
	Scanning frames descriptions and illustration, with probe arrangement (layout and scanning direction)
	Probes: quantity, manufacturer, types, beam angles, frequencies, single- or twin-crystal, element dimensions, number and arrangement of elements in probes. Focusing. Prob data sheets.
	Reference standard: Identification, description, and pain and sectional drawings showing all dimensions and reference reflectors (types, dimensions, location in plan and depth). Inspection certificates for the same. Acoustical of the reference reflectors.
	Calibration blocks
	Couplant and method of irrigation
	Weld seam tracking
<b>Calibration</b>	Calibrations, control checks and maintenance
<b>Standardization</b>	Range calibration
	Setting of sensitivity (PRG, transfer correction, PRL, scanning sensitivity)
	S: N ratio
	Recording levels (defect gate heights, start points and lengths)
	Method of monitoring coupling (with coupling gate heights, start points, lengths)
	Weld seam tracking and accuracy
<b>Inspection parameters</b>	Description of operation
	Guiding principle
	Scanning direction with respect to product axis
	Maximum permitted product travel speeds and probe traverse speeds
	Scan plans
	For HFW and SAW seams: scan plans for individual scans showing -6dB beam profile and probe offsets from datum-relative to reference reflector locations. Overall scan plan showing combination of scans. Scan plans shall be prepared using proprietary software and shall clearly demonstrate how 100% coverage of depth and width is achieved.
<b>Reference Table</b>	Table coordinating:
	Scan and channel numbers
	Probe identifications, types and scan direction
	Reference reflector types, identifications and locations
<b>Acceptance Criteria</b>	Interpretation, evaluation and acceptance criteria
<b>Reporting</b>	Report shall include at least the following items:
	Procedure identification and revision
	Application: Identification, description and dimensions (see above)
	All equipment used
	Result: accept or reject
	For all scans, the primary reference level used
	Position, depth and size of all discontinuities exceeding the recording level and all defects
	Date and time of inspection
Name of operator responsible for performing UT	

**Table AP4.2 – Penetrant Testing (PT)**

<b>Scope (application)</b>	Product from (e.g. weld, pipe end bevel, etc.)
	Material grade and specification
	Dimensions (pipe: length, diameter, thickness)
	Coverage required
	Weld process (as applicable)
	Reference to this specification and related standards
<b>Personnel</b>	Qualification requirements
	Performance demonstration – if required
<b>Stage of manufacture</b>	Stage at which PT is to be performed
<b>Surface Condition</b>	Condition and surface preparation of surfaces requiring inspection
<b>Inspection techniques</b>	Method for cleaning
	Method of applying penetrant
	Method of removing excess penetrant
	Method of drying surface
	Method of applying developer
	Whether color contrast or fluorescent
<b>Equipment and consumables</b>	Manufacturer type and designation of consumables (cleaner, penetrant, remover and developer).
	Requirement for certification of compliance of consumables (limits for sulfur and halogens)
	Light/UV-A meter, timer, sensitivity test blocks, timer, etc.
	Performance demonstration block– if required
<b>Calibration</b>	Calibrations, control checks and maintenance
<b>Inspection parameters</b>	Description of process
	Permitted time periods for process stages
	Light/UV-A Intensity ranges (for Light/UV-A, also include background white light)
	Applicable temperature limits
	Adjustment to stage duration if lower or upper temperature limits are exceeded
<b>Acceptance Criteria</b>	Interpretation, evaluation and acceptance criteria
<b>Reporting</b>	Report shall include at least the following items:
	Procedure identification and revision
	Application: Identification, description and dimensions (see above)
	All equipment and consumables used
	Result: accept or reject
	Position and size of all defects
	Date and time of inspection
	Name of operator responsible for performing PT

**Table AP4.3 – Magnetic Particle Testing (MT)**

<b>Scope (application)</b>	Product from (e.g. weld, pipe end bevel, etc.)
	Material grade and specification
	Dimensions (pipe: length, diameter, thickness)
	Coverage required
	Weld process (as applicable)
	Reference to this specification and related standards
<b>Personnel</b>	Qualification requirements
	Performance demonstration – if required
<b>Stage of manufacture</b>	Stage at which MT is to be performed.
<b>Surface Condition</b>	Condition and surface preparation of surfaces requiring inspection.
<b>Inspection techniques</b>	Magnetizing techniques and magnetizing directions (with illustration showing these)
	Type/waveform and amperage of magnetizing current
	Whether color contrast or fluorescent
<b>Equipment and consumables</b>	Manufacturer, type and designation of magnetic field generation (DC Yokes are not permitted)
	Manufacturer, type and designation of consumables (cleaning liquid, magnetic particles (wet or dry) and contrast medium)
	Light/UV-A meter, tangential field meter, flux indicator and residual field meter
	Lift block for AC Yoke
	Performance demonstration block– if required
<b>Calibration</b>	Calibrations, control checks and maintenance
<b>Inspection parameters</b>	Description of process
	Fill factors for rigid encircling strip (coil)s
	Method for cleaning
	Method of magnetization and method of applying magnetic particles – and whether “continuous” or “residual”
	Light or UV-A intensity ranges (for UV-A. also include background white light)
	Tangential field strength range requires (KA/m) – minimum and maximum
	Ink concentration range
	Applicable temperature limits
Adjustment to stage times if temperature limits are exceeded	
<b>Acceptance Criteria</b>	Interpretation, evaluation and acceptance criteria
<b>Reporting</b>	Report shall include at least the following items:
	Procedure identification and revision
	Application: Identification, description and dimensions (see above)
	All equipment and consumables used
	Result: accept or reject
	Position and size of all defects
	Date and time of inspection
	Name of operator responsible for performing MT

**Table AP4.4 – Electromagnetic Inspection (EMI)**

<b>Scope (application)</b>	Product from (e.g. SLMS pipe, HFW pipe, HFW weld seam).
	Material grade and specification
	Dimensions (pipe: length, diameter, thickness)
	Coverage required: coverage limits
	Weld process (as applicable)
	Reference to this specification and related standards
<b>Personnel</b>	Qualification requirements.
	Performance demonstration – if required
<b>Stage of manufacture</b>	Stage at which EMI is to be performed.
<b>Surface Condition</b>	Condition and surface preparation of surfaces requiring inspection.
<b>Inspection techniques</b>	Mode of inspection: differential or absolute or combination.
	Scanning mode: automated, manual
<b>Equipment</b>	Manufacturer, type and designation of EMI instrument and scanner
	Probe manufacturer, type, designations, sizes and arrangements
	Reference standard, identification, description, illustration, including all reference reflections
<b>Calibration</b>	Calibrations, control checks and maintenance
<b>Standardization</b>	Setting of sensitivity
	Recording levels (defect gate heights, start points and lengths)
<b>Inspection parameters</b>	Description of process
	Scanning direction with respect to product axis
	Frequencies, drive voltages and gain settings
	Minimum digitization rate
	Maximum permitted product travel speed and probe traverse speed
<b>Acceptance Criteria</b>	Interpretation, evaluation and acceptance criteria
<b>Reporting</b>	Report shall include at least the following items:
	Procedure identification and revision
	Application: Identification, description and dimensions (see above)
	All equipment used
	Result: accept or reject
	Scanning direction with respect to product axis
	Position and size of all defects
	Date and time of inspection
Name of operator responsible for performing EMI	



**Table AP4.5 – Radiographic Inspection (RT)**

<b>Scope (application)</b>	Product from (e.g. pipe longitudinal weld seam: pipe weld seam ends)
	Material grade and specification
	Dimensions (pipe: length, diameter, thickness: weld thickness including root and cap)
	Coverage required
	Weld process
	Weld preparation (drawing showing weld preparation dimensions and angles)
	Reference to this specification and related standards
<b>Personnel</b>	Qualification requirements
	Performance demonstration – if required
<b>Stage of manufacture</b>	Stage at which RT is to be performed e.g. for longitudinally welded pipe seams – after hydrotest.
<b>Surface Condition</b>	Condition and surface preparation of weld surfaces
<b>Inspection techniques</b>	Conventional film RT or digital (e.g. DR, DDA, CR)
	Single-wall/double-wall: source inside/outside: film/detector outside/inside
	Film processing: automated or manual
	Arrangement of equipment - description, with illustration
<b>Equipment</b>	X-ray set: manufacturer, type and designation. Maximum kV and amperage. Focal spot size (s)
	X-ray generator: manufacturer, type and designation. Maximum kV
	Film: brand, designation and sizes.
	Film processor: manufacturer, type and designation.
	Source/film/detector manipulation system
	Intensifying screens
	Digital detector: manufacturer, type and designation, dimension, number of pixels
	Imaging plate (IP): type, dimension, resolution
	Imaging plate scanner: manufacturer, type and designation. Resolution
	Film viewer: Sizes, maximum readable densities
Digital viewers/monitors: manufacturer, type, designation, size. Capabilities in terms of brightness, shades of gray, light intensity ratio, number of pixels	
Image quality indicators	
<b>Calibration</b>	Calibrations, control checks and maintenance
	For digital RT: as required by ISO 10893-7, plus routine checking of image archiving
<b>Inspection parameters</b>	Source-film/detector distance, object-film/detector distance, geometric unsharpness (Ug)
	Angle of beam centerline relative to weld centerline
	Maximum kV permitted relative to penetrated thickness
	Overlap of consecutive exposures
	Location of film/detector/IP, IQIs, Identification letters
	For digital RT: image quality class: permitted ranges for grey values and contrast: requirements for basic spatial resolution and signal-to-noise ratio
	IQI location and sensitivity
Storage conditions for unexposed and exposed films. Digital image archiving	
<b>Acceptance Criteria</b>	Interpretation, evaluation and acceptance criteria
<b>Reporting</b>	Report shall include at least the following items:
	Procedure identification and revision
	Application: Identification, description and dimensions (see above)
	All equipment used
	Result: accept or reject
	Position and size of all defects
	Date and time of inspection
Name of operator responsible for performing RT/interpreting images	

---

**Appendix 5  
(Informative)**

**Minimum Requirements to Order Sour-Service Plate**

**AP5.1 General**

Pipe manufacturer shall determine and prepare data about the following :

**a) Requirements for steel making**

- Electric furnace or basic oxygen.
- Deoxidation treatment.
- Vacuumed degasing.
- Ladle furnace Ar stirring.
- Through desulphurization.
- Treatment to control size, shape and distribution of oxide and manganese sulfide Inclusions.
- Banding.
- Fine grain practice.
- Full killed steel.

**b) Manufacturing procedure specification (MPS)**

- Reference standards.
- Dimensions including width, length, thickness, flatness, squareness and camber/plate length and tolerances.
- Slab chemical composition and grade.
- Manufacturer process arrangement (Flow chart).
- Slab numbering / traceability.
- Slab charging / loading system.
- Slab heat treatment.
- Slab descaling system.
- Plate rolling process.
- Plate heat treatment.
- Plate inspection area and method.
- Plate loading.

**c) Quality control plan (QCP) / Inspection and test plan (ITP)**

- Visual inspection.
- NDT.
- Physical tests.
- Mechanical tests.
- Corrosion tests.
- Marking and loading.
- Traceability.
- Inspector activity and frequency.

**Table AP5.1- Minimum Items of Quality Control check-list for Plate based on order requirements**

No	Quality Control check-list for Plate (Type of activity)
1	Manufacturer procedure specification (MPS) for Slab
2	Manufacturer procedure specification (MPS) for plate
3	Sulfur print and segregation analysis
4	Visual inspection
5	Dimensional inspection
6	Ultrasonic evaluation
7	Heat and product chemical analysis
8	Tensile test
9	Impact test
10	DWT test
11	Hardness test
12	CTOD test
13	Metallography (Inclusion, Banding, grain size, ...)
14	Corrosion tests (SSC and HIC)
15	Marking
16	Manufacturing documents and test reports
17	Shipment procedure
18	Manufacturer certificate

**AP5.2 Additional information**

- Pipe manufacturer is responsible for quality of plates completely.
- Pipe manufacturer shall prepare a final book about plate manufacturing and all related tests.
- All slabs shall have identified No. and Heat No.
- All slabs shall evaluate in standpoint of dimensional and specification before plate making.
- Both edge sides of all plates shall be inspected for defects and surface imperfections.
- Both edge sides of all plates shall be check via ultrasonic for cracks, laminations, holes ... .
- Both longitudinal edges of all plates shall be cut, if specified by the purchaser.
- All plates shall have marking and code according to AIAG-B1 standard. Marking shall include at least: Mfg/Trade Mark, material, heat No., plate identifier, delivery condition (heat treatment type), dimension, weight, service condition and date.
- Repairing by welding is not acceptable.
- All manufacturing stages shall be traceable.
- All tests results shall be according to IPS criteria or other related standard which approved by purchaser.
- Third party inspector shall prepare manufacturing certificate for all plates.
- Shipment of plates shall be carried out under third party inspector supervision, if specified by the purchaser.

**Appendix 6  
(Informative)**

**Typical MPS/QCP-ITP document**

<b>Manufacturer Logo</b>	<b>Manufacturer Name :</b>	<b>Order No:</b>	<b>Item No:</b>	<b>Supplier Logo</b>
	<b>Supplier Name :</b>	<b>Contract No:</b>	<b>Rev:</b>	
	<b>Client Name :</b>	<b>Page : of</b>	<b>Date:</b>	
	<b>Document Name :</b>	<b>Ref / Doc No:</b>		

**Typical MPS/QCP-ITP document**

# MPS/QCP-ITP

**(SEAMLESS & WELDED LINE PIPE)**

(MANUFACTURE PROCESS SPECIFICATION / QUALITY CONTROL PLAN - INSPECTION AND TEST PLAN )

**Manufacturer Name :**

**Supplier (Customer Name) :**

**Client (Purchaser Name) :**

**Order No:**

Item No.	Product Description
	As per PMR : Type of Pipeline, OD, Grade & PSL, W.T, Service Condition, Type of pipe end-finished

Priority	Applicable References
	As per PMR : Title of Reference, Edition, Date

Rev. No.	Originated	Date	Checked	Date	Approved	Date
	Manufacturer		Supplier		Client or AM	

---

**Contents**

<b>Title</b>	<b>Page</b>
G. General Requirements	106
1. Pre-Inspection Meeting	110
2. Pipe Manufacturing	110
3. Chemical Composition	111
4. Mechanical Testing	112
5. Pressure Testing	114
6. Non-Destructive Inspection	114
7. Visual and Dimensional Inspection	116
8. Corrosion Testing	117
9. Marking	118
10. Packing, Storage and Shipping	118
11. Documentation	119
12. ANNEX I : Manufacturing Process Chart of Pipe	119
13. ANNEX II : Heat treatment Process Chart of Pipe	119
14. ANNEX III : Welding Procedure Specification (WPS) for Welded pipe	119
15. ANNEX IV : Procedure Qualification Record (PQR) for Welded pipe	119

---

**General****G.1. Scope**

This document specifies requirements for manufacturing of seamless and welded pipe for use in pipeline transportation systems in the petroleum, petrochemical and natural gas industries.

- This specification gives the acceptance criteria for the manufacturing, inspection and testing of the referenced order.
- Product inspection level for this order is LEVEL 1, which in product manufacturing shall be carried out in presence of owner inspector according to this document.

**G.2. Priority of documents**

1. This MPS/QCP-ITP
2. IPS-M-PI-190
3. API 5L

- Any probable conflict shall be confirmed with COMPANY.

**G.3. First-day tests**

Fulfill according to relevant contract standards/documents and COMPANY's requirements.

**G.4. Calibration**

Fulfill according to relevant contract standards/documents and COMPANY's requirements.

**G.5. Test unit**

Fulfill according to relevant contract standards/documents and COMPANY's requirements.

**G.6. ITP Legend**

- **Hold Point (H):** Inspector invited to observe a specific operation. If inspector fails to attend, the operation can not proceed without Inspector Presence.
- **Witness Point (W):** Inspector invited to observe a specific operation. If inspector fails to attend, the operation can proceed without Inspector Presence.
- **Document Review (R):** No invitation to inspector. Established records and reports are available on request.

Any other inspection activity shall be defined as COMPANY's requirements.

**G.7. MPS Information**

Fulfill according to relevant contract standards/documents and COMPANY's requirements.

Generally, the manufacturer shall supply the purchaser with summary information or identification of the control documents, as applicable, on the main characteristics of the manufacturing procedure. This information shall include at least the following:

**a) Steelmaking and casting (For all Pipe):**

1. Name/location of manufacturing facility;
2. Equipment and process description including steelmaking method, heat size, inclusion shape control practices, casting method and vacuum degassing and deoxidation practice;
3. Chemical composition ranges including all elements intentionally added;
4. Steelmaking and casting process control;
5. Hydrogen control practices (where applicable);
6. Product identification and traceability practices;
7. Product rework/retest/release controls for non-conformances to manufacturer's documented practices including grade intermixes/transitions and process/chemistry deviations;
8. Centerline segregation controls and acceptance criteria, as applicable.

**b) Pipe manufacturing (For all Pipe):**

1. Name/location of manufacturing facility;
2. Equipment and process description;
3. Hydrostatic testing practices including calibration/verification of equipment;
4. Non-destructive inspection methods and practices including instrument standardization practices;
5. Chemical/mechanical property test and retest sample location(s) and specimen specification;
6. Dimensional control methods including methods to straighten pipe or correct dimensions;
7. For full body normalized and quenched and tempered pipe, the aim and control tolerances for the austenitizing and tempering times and temperatures and a description of the temperature monitoring and control methods;
8. Pipe marking process and details;
9. Product traceability practices from starting material (as billet, coil, and plate) receipt to pipe release;
10. Product rework/retest/release controls for non-conformances from manufacturer's documented practices;
11. Pipe storage, handling, loading and shipping practices.

**c) For SMLS Pipe:**

1. pipe-forming process for as-rolled pipe:
  - o applicable rolling practice control temperature tolerances (reheating, rolling and cooling);
  - o applicable time tolerances (reheating, rolling and cooling);
2. pipe heat-treatment practice.

**d) For welded pipe:**

1. Pipe-forming procedures, including preparation of edges, control of alignment and shape;
2. Pipe heat-treatment procedure, where applicable, including in-line heat treatment of the weld seam;
3. Welding procedure specification with previous qualification records for this procedure, if

available. This shall include sufficient information of the following kind:

- i) For HFW seam welding:
  - o confirmation of adequate weld seam heat treatment through metallography;
  - o description and controls of welding process;
- ii) For SAW seam, repair, coil/plate end, and jointer welding, as applicable:
  - o wire/flux consumable manufacturer(s), classification and wire diameter(s);
  - o welding parameters and ranges including current, voltage, travel speed, heat input;
- 4. For SAW pipes:
  - i) Seam welding bevel dimensional tolerances;
  - ii) Method of tack welding and spacing of tack welds (if applicable);
  - iii) Procedures for wire and flux storage and handling including moisture control and practices for recycling flux, as applicable;
  - iv) Weld defect removal methods.

**e) Hot rolling - for welded pipe:**

1. Name/location of manufacturing facility;
2. Equipment and process description, including heat-treatment method (N or Q) if applicable;
3. Applicable rolling practice control temperature tolerances (reheating, rolling and cooling);
4. Applicable time tolerances (reheating, rolling, and cooling);
5. Applicable non-destructive inspection methods and practices for the coil/plate including instrument standardization practices;
6. Dimensional and mechanical property control limits;
7. End cropping practices;
8. Product traceability practices from slab receipt to plate/coil delivery;
9. Product rework/retest/release controls for non-conformances to manufacturer's documented practices (including process, chemical/ mechanical, and dimensional deviations),
10. Storage, handling, loading and shipping practices.

**f) Secondary processing (if applicable) – for welded pipe:**

1. Name/location of manufacturing facility;
2. Equipment and process description;
3. Product identification and traceability practices from plate/coil receipt to plate/coil delivery;
4. Product rework/recoil/retest/release controls for non-conformances from manufacturer's documented practices (including process, chemical/ mechanical, and dimensional deviations),
5. Storage, handling, loading and shipping practices.

**g) For HFW pipe:**

The seam welding procedure shall also include details of the following:

1. Methods to be used for heating strip edges and for the control and monitoring of power input in relation to the temperature of the pipe surface and the speed of the pipe;
2. Frequency (in kHz) of the welding power supply;



3. Welding speed;
4. Welding Temperature;
5. Welding power;
6. Compressive force or displacement used in welding;
7. Temperature of in-line normalizing (if applied) ;
8. Details of any protective atmosphere used for welding;
9. Methods used to accomplish and control the upset welding of the heated pipe edges;
10. Methods used for trimming of the weld bead.

**h) For SAW pipe:**

1. Plate manufacturing method including details of specialized cooling and heat treatment;
2. Plate NDT procedures;
3. Pipe forming procedure;
4. Seam welding procedure including details of the following:
  - o Method of alignment, clamping and tack welding (if any) of the joints to be welded together with details of run-on and run-off tabs to be used and the method of their attachment to the pipe;
  - o For pipe made by the cage-forming process, details of the methods used to maintain the alignment of the inside and outside welds;
  - o Welding process;
  - o Brand name, classification, size and grade of filler metal and flux;
  - o Speed of welding;
  - o Number of electrodes and polarity for each electrode ;
  - o Welding current for each wire ;
  - o Welding voltage for each wire ;
  - o Dimensions of welding preparation;
  - o Number of weld passes and their disposition ;
  - o Details of tracking system for both inside and outside welding and also method for checking the set up of the system ;
  - o Limits on internal and external weld reinforcement ;
  - o Repair welding procedure;
  - o The method and degree of expansion to be applied ;
  - o Pipe heat treatment procedure (when appropriate);
  - o Hydrostatic test procedure ;
  - o NDT procedure.

**G.8 QCP-ITP Information**

Fulfill according to relevant contract standards/documents and COMPANY's requirements.

Inspection and Test Plan shall include at least the following:

1. Relevant standard for each test.

2. Inspection activity and Inspection points;
3. Organization or individuals responsible for performing the inspection activity (including manufacturer, subcontractor, purchaser or third party representative);
4. Inspection/test and calibration practices, as applicable;
5. Frequency of inspection;
6. Acceptance criteria;
7. Actions to non-conformances;
8. Result recording, as applicable;
9. Identification of processes requiring validation;

Item. Title	Description and Acceptance Criteria	Frequency	Inspection	
			Mill	Inspector
1.	<b>Pre-Inspection Meeting: Discussion including all requirements.</b> Any following parts shall be Fulfilled according to relevant contract standards/documents and other supplementary COMPANY's requirements.			
2.	<b>Pipe Manufacturing</b>			
<b>2.1 : Steel Making For all pipes</b>	In addition to information in part G of this document, this section shall include minimum requirements as follow : ➤ Reference document: (Standard, Procedure...) ➤ Steel is made by: (Manufacturer of starting material). ➤ Type of furnace and Process : ➤ Casting method : ➤ Refining technique : ➤ Steel condition: (fully killed, Fine grain...) ➤ Heat treatment condition : ➤ Dimension and type of starting material: (Ingot, Billet, Bloom, Coil or Plate...) ➤ Traceability and label of starting material (Billet, Bloom, Coil or Plate...) containing heat No. , material name, weight, related documents and certificates. ➤ Starting material Inspection and Quality control: (Including Heat No., Length, Dimension, Weight, Marking, Surface quality, Repair, NDT, Chemical composition, Mechanical properties...) ➤ Produced reports/Doc: (Table, Chart, Data...) ➤ Remarks :	<b>First-day</b>		
		<b>Production</b>		
<b>2.2 : Pipe Manufacturing Process For SMLS pipe</b>	In addition to information in part G of this document, this section shall include minimum requirements as follow : ➤ Reference document: (Standard, Procedure...) ➤ Manufacturing method for SMLS pipe: (Such as Mannesmann Process: Piercing, Rolling, Plug Mill, Mandrel Mill, Reeling .../ Extrusion Process.../ Forging Process...) ➤ Heating the starting material: (Equipment and type of furnace, Temperature, ...). ➤ Pipe forming: (As rolled, hot forming...) ➤ Hot operations: (Such as sizing, Finish, Rolling...) ➤ Cold operations: (Such as Straightening, sizing, Finishing, Expanding, Drawing, Stretch reducing...) ➤ Sizing ratio for cold expanded pipe : ➤ Traceability, Inspection, Quality control and Repair: ➤ Manufacturing Process Chart of SMLS Pipe shall illustrate in Annex I. ➤ Produced reports/Doc: (Table, Chart, Data...) ➤ Remarks :	<b>First-day</b>		
		<b>Production</b>		

<p><b>2.3 :</b> <b>Pipe Manufacturing Process</b>  <b>For welded pipe</b></p>	<p>In addition to information in part G of this document, this section shall include minimum requirements as follow :</p> <ul style="list-style-type: none"> <li>➤ Reference document: (Standard, Procedure...).</li> <li>➤ Manufacturing method for welded pipe: (Preparation of edges for welding and acceptable criteria for machining or shearing...).</li> <li>➤ Heating the starting material: (Equipment and type of furnace, Temperature, ...).</li> <li>➤ Pipe forming: (As rolled, hot forming...).</li> <li>➤ Hot operations: (Such as sizing, Finish, Rolling...).</li> <li>➤ Cold operations: (Such as Straightening, sizing, Finishing, Expanding, Drawing, Stretch reducing...).</li> <li>➤ Sizing ratio for cold expanded pipe :</li> <li>➤ Traceability, Inspection, Quality control and Repair:</li> <li>➤ Manufacturing Process Chart of welded Pipe shall illustrate in Annex I.</li> <li>➤ Welding Procedure Specification (WPS) for welded pipe shall illustrate in Annex III.</li> <li>➤ Procedure Qualification Record (PQR) for welded pipe shall illustrate in Annex IV.</li> <li>➤ Produced reports/Doc: (Table, Chart, Data...).</li> <li>➤ Remarks</li> </ul>	<b>First-day</b>		
		<b>Production</b>		
<p><b>2.4 :</b> <b>Heat Treatment</b>  <b>For all pipes</b></p>	<p>This section shall include minimum requirements as follow :</p> <ul style="list-style-type: none"> <li>➤ Reference document: (Standard, Procedure...)</li> <li>➤ Heat treatment process: (Method and Delivery condition of pipes, Equipment and type of furnace, Temperature, Holding time...).</li> <li>➤ Heat treatment Process Chart of Pipe shall illustrate in Annex II.</li> <li>➤ Produced reports/Doc: (Table, Chart, Data...).</li> <li>➤ Remarks :</li> </ul>	<b>First-day</b>		
		<b>Production</b>		
<b>3.</b>	<b>Chemical Composition</b>			
<p><b>3.1 :</b> <b>Heat and Product Analysis</b>  <b>For all pipes</b></p>	<p>For first-day &amp; production, this section shall include minimum requirements as follow :</p> <ul style="list-style-type: none"> <li>➤ Reference document: (Standard, Procedure...)</li> <li>➤ Equipment and Method of analysis :</li> <li>➤ Location, Orientation, Number and Dimensions of samples :</li> <li>➤ Heat analysis and Product analysis :</li> <li>➤ Tolerance for chemical composition :</li> <li>➤ Ratios &amp; sum of element contents :</li> <li>➤ <math>CE_{IIV}</math>, <math>CE_{Pcm}</math> Equations (whichever is needed) :</li> <li>➤ Produced reports/Doc: (Table, Chart, Data...).</li> <li>➤ Retest:</li> <li>➤ Remarks :</li> </ul>	<b>First-day</b>		
		<b>Production</b>		
<p><b>3.2 :</b> <b>Metallographic Examination (Micro &amp; Macro)</b>  <b>For all pipes</b></p>	<p>For first-day &amp; production, this section shall include minimum requirements as follow :</p> <ul style="list-style-type: none"> <li>➤ Reference document: (Standard, Procedure...)</li> <li>➤ Equipment and Method of analysis :</li> <li>➤ Location, Orientation, Number and Dimensions of samples :</li> <li>➤ Microstructure examination, Banding, Inclusion rate &amp; Acceptance criteria :</li> <li>➤ Produced reports/Doc: (Table, Chart, Data...).</li> <li>➤ Retest :</li> <li>➤ Remarks :</li> </ul>	<b>First-day</b>		
		<b>Production</b>		

4. Mechanical Testing			
<b>4.1 :</b> <b>Tensile Properties</b>  <b>Pipe body :</b> <b>For all pipes</b>  <b>Seam weld :</b> <b>For welded pipes</b>	For first-day & production, this section shall include minimum requirements as follow :  ➤ Reference document: (Standard, Procedure...) ➤ Equipment and Test method : ➤ Location, Orientation, Number and Dimensions of samples : ➤ Min & Max of Yield strength ( $R_{10.5}$ ) : ➤ Min & Max of Tensile strength ( $R_m$ ) : ➤ Ratio = ( $R_{10.5}/R_m$ ): ➤ Elongation( $A_1$ ):(According to gauge length:50 mm) ➤ $A_1$ Equation : ➤ Tensile strength of weld seam ( <u>Only for welded pipe</u> ) : ➤ Produced reports/Doc: (Table, Chart, Data...). ➤ Retest : ➤ Remarks :	<b>First-day</b>	
		<b>Production</b>	
<b>4.2 :</b> <b>Hardness Properties</b> <b>Pipe body :</b> <b>For all pipes</b>  <b>Seam weld &amp; HAZ:</b> <b>For welded pipes</b>  <b>Hard Spots:</b>	For first-day & production, this section shall include minimum requirements as follow :  ➤ Reference document: (Standard, Procedure...) ➤ Equipment and Test method : ➤ Location, Orientation, Number and Dimensions of samples : (Number and interval of indentation, Distance to surface of traverses) ➤ Range of hardness value & Acceptance criteria : ➤ Produced reports/Doc: (Table, Chart, Data...). ➤ Retest : ➤ Remarks :	<b>First-day</b>	
		<b>Production</b>	
<b>4.3 :</b> <b>CVN - Impact Properties</b> <b>Pipe body :</b> <b>For all pipes</b>  <b>Seam weld and HAZ :</b> <b>For welded pipes</b>	For first-day & production, this section shall include minimum requirements as follow :  ➤ Reference document: (Standard, Procedure...) ➤ Equipment and Test method : ➤ Location, Orientation, Number and Dimensions of samples : ➤ CVN absorbed energy (Individual, Min average) : ➤ Test temperature : ➤ Shear fracture area : ➤ Full transition temperature curve : ➤ Produced reports/Doc: (Table, Chart, Data...). ➤ Retest : ➤ Remarks :	<b>First-day</b>	
		<b>Production</b>	
<b>4.4 :</b> <b>Drop-weight tear test</b>  <b>Pipe body :</b> <b>For welded pipes</b>	For first-day & production, this section shall include minimum requirements as follow :  ➤ Reference document: (Standard, Procedure...) ➤ Equipment and Test method : ➤ Location, Orientation, Number and Dimensions of samples : ➤ Average shear fracture area : ➤ individual and average test results for each test : ➤ Test temperature : ➤ Full transition curves : ➤ Acceptance criteria : ➤ Produced reports/Doc: (Table, Chart, Data...). ➤ Retest : ➤ Remarks :	<b>First-day</b>	
		<b>Production</b>	

<p><b>4.5 :</b> <b>Flattening test</b> <b>Pipe body &amp; weld</b> <b>For HFW pipe</b></p>	<p>For first-day &amp; production, this section shall include minimum requirements as follow :</p> <ul style="list-style-type: none"> <li>➤ Reference document: (Standard, Procedure...)</li> <li>➤ Equipment and Test method :</li> <li>➤ Location, Orientation, Number and Dimensions of samples :</li> <li>➤ Acceptance criteria :</li> <li>➤ Produced reports/Doc: (Table, Chart, Data...).</li> <li>➤ Retest :</li> <li>➤ Remarks :</li> </ul>	<b>First-day</b>		
		<b>Production</b>		
<p><b>4.6 :</b> <b>Guided-bend testing</b> <b>Seam weld :</b> <b>For SAW</b></p>	<p>For first-day &amp; production, this section shall include minimum requirements as follow :</p> <ul style="list-style-type: none"> <li>➤ Reference document: (Standard, Procedure...)</li> <li>➤ Equipment and Test method :</li> <li>➤ Location, Orientation, Number and Dimensions of samples :</li> <li>➤ Acceptance criteria :</li> <li>➤ Produced reports/Doc: (Table, Chart, Data...).</li> <li>➤ Retest :</li> <li>➤ Remarks :</li> </ul>	<b>First-day</b>		
		<b>Production</b>		
<p><b>4.7 :</b> <b>CTOD</b> <b>For all pipes</b></p>	<p>For first-day and production, this section shall include minimum requirements as follow :</p> <ul style="list-style-type: none"> <li>➤ Reference document: (Standard, Procedure...)</li> <li>➤ Equipment and Test method :</li> <li>➤ Location, Orientation, Number and Dimensions of samples :</li> <li>➤ Acceptance criteria :</li> <li>➤ Produced reports/Doc: (Table, Chart, Data...).</li> <li>➤ Retest :</li> <li>➤ Remarks :</li> </ul>	<b>First-day</b>		
		<b>Production</b>		
<p><b>4.8 :</b> <b>Spring back</b> <b>For HFW and</b> <b>SAWH</b></p>	<p>For first-day and production, this section shall include minimum requirements as follow :</p> <ul style="list-style-type: none"> <li>➤ Reference document: (Standard, Procedure...)</li> <li>➤ Equipment and Test method :</li> <li>➤ Location, Orientation, Number and Dimensions of samples :</li> <li>➤ Acceptance criteria :</li> <li>➤ Produced reports/Doc: (Table, Chart, Data...).</li> <li>➤ Retest :</li> <li>➤ Remarks :</li> </ul>	<b>First-day</b>		
		<b>Production</b>		

5.	Pressure Testing			
<p><b>5.1 : Hydrostatic Test</b></p> <p><b>For all pipes</b></p>	<p>For first-day &amp; production, this section shall include minimum requirements as follow :</p> <ul style="list-style-type: none"> <li>➤ Reference document: (Standard, Procedure...)</li> <li>➤ Equipment and Test method :</li> <li>➤ Test pressure value :</li> <li>➤ Holding time under pressure :</li> <li>➤ Parameters &amp; equation for calculation of pressure:</li> <li>➤ Produced reports/Doc: (Table, Chart, Data...).</li> <li>➤ Retest :</li> <li>➤ Remarks :</li> </ul> <p>❖ <b>Note:</b> Test pressure shall be calculated on the basis of the specified wall thickness which is ordered wall thickness.</p>	<b>First-day</b>		
		<b>Production</b>		
6.	Non-Destructive Inspection			
<p><b>6.1 : Ultrasonic Inspection</b></p> <p><b>Pipe Body &amp; End: For all pipes</b></p> <p><b>Coil/strip/plate body, end, edge or areas adjacent to the weld seam: For welded pipe</b></p> <p><b>Weld seam: For welded pipe</b></p>	<p>For first-day &amp; production, this section shall include minimum requirements as follow :</p> <ul style="list-style-type: none"> <li>➤ Reference document: (Standard, Procedure...)</li> <li>➤ Equipment and Test method :</li> <li>➤ Location, Orientation, wide zone and inspection length (full &amp; end of pipe), repaired areas and overlaps for scanning coverage:</li> <li>➤ Ultrasonic inspection for longitudinal and transversal imperfections inside &amp; outside :</li> <li>➤ Ultrasonic inspection for Lamination :</li> <li>➤ Ultrasonic wall thickness measurements:</li> <li>➤ Acceptance criteria for defect &amp; imperfections :</li> <li>➤ Acceptance criteria for laminar imperfections including Maximum individual imperfection (Area, Length), Minimum imperfection size considered (Area, engh,width), Maximum population density.</li> <li>➤ Produced reports/Doc: (Table, Chart, Data...).</li> <li>➤ Retest :</li> <li>➤ Remarks :</li> </ul> <p>❖ <b>Note:</b> The required non-destructive inspections of pipe shall take place after all heat treating and cold-expansion operations.</p>	<b>First-day</b>		
		<b>Production</b>		
<p><b>6.2 : Radiographic Inspection</b></p> <p><b>Weld seam: For SAW pipe</b></p> <p><b>weld seam at the pipe end: For SAW pipes</b></p>	<p>For first-day &amp; production, this section shall include minimum requirements as follow :</p> <ul style="list-style-type: none"> <li>➤ Reference document: (Standard, Procedure...)</li> <li>➤ Equipment and Test method (technique) :</li> <li>➤ Location, Orientation, wide zone and inspection length (full &amp; end of pipe), repaired areas and overlaps for scanning coverage:</li> <li>➤ Image quality indicators (IQIs):</li> <li>➤ Traceability of radiographic images :</li> <li>➤ Inspection for longitudinal and transversal imperfections inside &amp; outside :</li> <li>➤ Acceptance criteria for defect &amp; imperfections :</li> <li>➤ Inspection for Lamination :</li> <li>➤ Produced reports/Doc: (Table, Chart, Data...).</li> <li>➤ Retest :</li> </ul>	<b>First-day</b>		

	<ul style="list-style-type: none"> <li>➤ Remarks :</li> <li>➤ <b>Note:</b> The required non-destructive inspections of pipe shall take place after all heat treating and cold-expansion operations.</li> </ul>	<b>Production</b>		
<p style="text-align: center;"><b>6.3 :</b> <b>Electromagnetic</b> <b>Inspection</b></p> <p><b>Pipe Body &amp; End:</b> <b>For SMLS pipes</b> <b>with W.T&lt; 6 mm</b></p>	<p>For first-day &amp; production, this section shall include minimum requirements as follow :</p> <ul style="list-style-type: none"> <li>➤ Reference document: (Standard, Procedure...)</li> <li>➤ Equipment and Test method :</li> <li>➤ Location, Orientation, wide zone and inspection length (full &amp; end of pipe), repaired areas and overlaps for scanning of samples:</li> <li>➤ Electromagnetic inspection for longitudinal and transversal surface imperfections (outside):</li> <li>➤ Acceptance criteria for imperfections :</li> <li>➤ Residual Magnetism : (Number, Average and Maximum of readings)</li> <li>➤ Produced reports/Doc: (Table, Chart, Data...).</li> <li>➤ Retest :</li> <li>➤ Remarks :</li> <li>❖ <b>Note:</b> The required non-destructive inspections of pipe shall take place after all heat treating and cold-expansion operations.</li> </ul>	<b>First-day</b>		
		<b>Production</b>		
<p style="text-align: center;"><b>6.4 :</b> <b>Magnetic Particle</b> <b>Inspection</b></p> <p><b>Pipe end face,</b> <b>bevel :</b> <b>For all pipes</b></p>	<p>For first-day &amp; production, this section shall include minimum requirements as follow :</p> <ul style="list-style-type: none"> <li>➤ Reference document: (Standard, Procedure...)</li> <li>➤ Equipment and Test method :</li> <li>➤ Location, Orientation, wide zone and inspection length (full &amp; end of pipe), repaired areas and overlaps for scanning of samples :</li> <li>➤ Magnetic particle inspection for laminar imperfections</li> <li>➤ Acceptance criteria for imperfections :</li> <li>➤ Residual Magnetism : (Number, Average and Maximum of readings)</li> <li>➤ Produced reports/Doc: (Table, Chart, Data...).</li> <li>➤ Retest :</li> <li>➤ Remarks :</li> <li>❖ <b>Note:</b> If UT has not been performed from the outside and if UT from the inside is not feasible due to dimensional limitations, the end face/bevel at each pipe end shall be magnetic particle inspected for the detection of laminar imperfections.</li> <li>❖ <b>Note:</b> The required non-destructive inspections of pipe shall take place after all heat treating and cold-expansion operations.</li> </ul>	<b>First-day</b>		
		<b>Production</b>		

<p><b>6.5 :</b> <b>Penetrant Test or Magnetic Particle</b></p> <p><b>Weld seam:</b> <b>For welded pipe</b></p> <p><b>Pipe Body:</b> <b>For SMLS pipes</b></p>	<p>For first-day &amp; production, this section shall include minimum requirements as follow :</p> <ul style="list-style-type: none"> <li>➤ Reference document: (Standard, Procedure...)</li> <li>➤ Equipment and Test method :</li> <li>➤ Location, Orientation, wide zone and inspection length (full &amp; end of pipe), repaired areas and overlaps for scanning of samples :</li> <li>➤ Acceptance criteria for discontinuities:</li> <li>➤ Residual Magnetism : (Number, Average and Maximum of readings)</li> <li>➤ Produced reports/Doc: (Table, Chart, Data...).</li> <li>➤ Retest :</li> <li>➤ Remarks :</li> </ul>	<b>First-day</b>		
		<b>Production</b>		
<b>7.</b>	<b>Visual and Dimensional Inspection</b>			
<p><b>7.1 :</b> <b>Surface condition</b></p> <p><b>For all pipe</b></p>	<p>For first-day &amp; production, this section shall include minimum requirements as follow :</p> <ul style="list-style-type: none"> <li>➤ Reference document: (Standard, Procedure...)</li> <li>➤ Equipment and Test method :</li> <li>➤ Location for examination of samples (Pipe body, Pipe end, Pipe outside &amp; inside...):</li> <li>➤ Illuminance for examination :</li> <li>➤ Examination for imperfections and defects (such as cracks, sweats, leaks, lamination, hard spots, dents and other geometric deviations...):</li> <li>➤ Acceptance criteria for undercut and arc burn (<u>only for welded pipe</u>) :</li> <li>➤ Acceptance criteria for imperfections and defects :</li> <li>➤ Produced reports/Doc: (Table, Chart, Data...).</li> <li>➤ Retest :</li> <li>➤ Repair :</li> <li>➤ Remarks :</li> </ul>	<b>First-day</b>		
		<b>Production</b>		



<p><b>7.2 : Dimensional Condition</b></p> <p><b>For all pipe</b></p>	<p>For first-day &amp; production, this section shall include minimum requirements as follow :</p> <ul style="list-style-type: none"> <li>➤ Reference document: (Standard, Procedure...)</li> <li>➤ Equipment and Test method :</li> <li>➤ Location for examination of samples (Pipe body, Pipe end, Pipe outside &amp; inside...):</li> <li>➤ Diameter tolerances (Pipe except the end &amp; Pipe end):</li> <li>➤ Out-of-roundness tolerances (Pipe except the end &amp; Pipe end) :</li> <li>➤ Tolerances for wall thickness :</li> <li>➤ Average length of pipes, minimum percent of pipes in specified range of length, Min &amp; Max of pipe length:</li> <li>➤ Tolerances for straightness (Total deviation from a straight line, Local deviation from a straight line):</li> <li>➤ Tolerances for Mass (Weight):</li> <li>➤ Out-of-squareness:</li> <li>➤ Bevel angle and tolerance :</li> <li>➤ Width of the root face and tolerance :</li> <li>➤ Tolerances for the weld seam (<u>only for welded pipe</u>) : (Including Radial offset of strip/plate edges, Height of the flash or weld bead/reinforcement, Misalignment of the weld beads of SAW).</li> <li>➤ Produced reports/Doc: (Table, Chart, Data...).</li> <li>➤ Retest :</li> <li>➤ Repair :</li> <li>➤ Remarks :</li> </ul>	<p><b>First-day</b></p>		
		<p><b>Production</b></p>		
<p><b>8.</b></p>	<p><b>Corrosion Testing</b></p>			
<p><b>8.1 : Hydrogen-induced cracking (HIC) Test</b></p> <p><b>For all pipe</b></p>	<p>For first-day &amp; production, this section shall include minimum requirements as follow :</p> <ul style="list-style-type: none"> <li>➤ Reference document: (Standard, Procedure...)</li> <li>➤ Equipment and Test method: (Test solution and solution control such as temperature, H2S concentration, pH...)</li> <li>➤ Location, Orientation, Number and Dimensions of samples :</li> <li>➤ Acceptance criteria ( CLR, CSR, CTR, Crack length, Blistering area ... ) :</li> <li>➤ Test duration :</li> <li>➤ Produced reports/Doc: (Table, Chart, Data...).</li> <li>➤ Retest :</li> <li>➤ Remarks :</li> </ul>	<p><b>First-day</b></p>		
		<p><b>Production</b></p>		
<p><b>8.2 : Sulfide stress cracking (SSC) Test</b></p> <p><b>For all pipe</b></p>	<p>For first-day &amp; production, this section shall include minimum requirements as follow :</p> <ul style="list-style-type: none"> <li>➤ Reference document: (Standard, Procedure...)</li> <li>➤ Equipment and Test method: (Test solution and solution control such as temperature, H2S concentration, pH...)</li> <li>➤ Location, Orientation, Number and Dimensions of samples :</li> <li>➤ Acceptance criteria :</li> <li>➤ Test duration :</li> <li>➤ Samples under load stress value :</li> <li>➤ Produced reports/Doc: (Table, Chart, Data...).</li> <li>➤ Retest :</li> <li>➤ Remarks :</li> </ul>	<p><b>First-day</b></p>		
		<p><b>Production</b></p>		

9.	Marking			
<p><b>9.1 :</b> <b>Paint stenciling</b></p> <p><b>For all pipe</b></p>	<p>This section shall include minimum requirements as follow :</p> <ul style="list-style-type: none"> <li>➤ Reference document: (Standard, Procedure...)</li> <li>➤ Equipment and method :</li> <li>➤ Location of marking on pipe :</li> <li>➤ Produced reports/Doc: (Table, Chart, Data...).</li> <li>➤ Remarks:</li> </ul> <p>Pipe marking shall include at least the following information sequentially :</p> <ul style="list-style-type: none"> <li>➤ Name or mark of the manufacturer of the pipe :</li> <li>➤ "API Spec 5L" and "IPS-M-PI-190 ()"shall be marked:</li> <li>➤ Specified outside diameter:</li> <li>➤ Specified wall thickness:</li> <li>➤ Pipe steel grade :</li> <li>➤ Product specification level designation (PSL ( )):</li> <li>➤ Type of pipe (SMLS...):</li> <li>➤ Mark of the customer's inspection representative :</li> <li>➤ Pipe No.</li> <li>➤ TESTED shall be marked for specified hydrostatic test pressure:</li> <li>➤ Heat number of pipe:</li> <li>➤ Pipe marking shall carry "sour service" or "Non-Sour service" to indicate pipe service condition.</li> <li>➤ Order No. :</li> <li>➤ Length of pipe:</li> <li>➤ Weight:</li> </ul>	<p><b>Production</b></p>		
<p><b>9.2 :</b> <b>Paint Colour</b></p> <p><b>For all pipe</b></p>	<p>This section shall include minimum requirements as follow :</p> <ul style="list-style-type: none"> <li>➤ Reference document: (Standard, Procedure...)</li> <li>➤ Equipment and method :</li> <li>➤ Location and width of paint strip on pipe :</li> <li>➤ Produced reports/Doc: (Table, Chart, Data...).</li> <li>➤ Remarks:</li> </ul> <p>❖ <b>Note:</b> On HFW pipe, the manufacturer shall apply a 50 mm wide daub of heat resistant white paint on the inside surface at each end of each pipe to mark the location of the weld line.</p>	<p><b>Production</b></p>		
10.	Packing, Storage and Shipping			
<p><b>10.1 :</b> <b>Packing Requirements</b></p> <p><b>For all pipe</b></p>	<p>This section shall include minimum requirements as follow :</p> <ul style="list-style-type: none"> <li>➤ Reference document: (Standard, Procedure...)</li> <li>➤ Equipment and method :</li> <li>➤ Delivery Condition of pipe: (Bare, Uncoiled, end protected caps...)</li> <li>➤ Produced reports/Doc: (Table, Chart, Data...).</li> <li>➤ Remarks:</li> </ul>	<p><b>Production</b></p>		
<p><b>10.2 :</b> <b>Storage Requirements</b></p> <p><b>For all pipe</b></p>	<p>This section shall include minimum requirements as follow :</p> <ul style="list-style-type: none"> <li>➤ Reference document: (Standard, Procedure...)</li> <li>➤ Equipment and method :</li> <li>➤ Produced reports/Doc: (Table, Chart, Data...).</li> <li>➤ Remarks:</li> </ul>	<p><b>Production</b></p>		
<p><b>10.3 :</b> <b>Shipping Requirements</b></p> <p><b>For all pipe</b></p>	<p>This section shall include minimum requirements as follow :</p> <ul style="list-style-type: none"> <li>➤ Reference document: (Standard, Procedure...)</li> <li>➤ Equipment and method :</li> <li>➤ Produced reports/Doc: (Table, Chart, Data...).</li> <li>➤ Remarks:</li> </ul>	<p><b>Production</b></p>		

11.	Documentation			
<p><b>11.1 : Documents</b></p> <p><b>For all pipe</b></p>	<p>This section shall include minimum requirements as follow :</p> <ul style="list-style-type: none"> <li>➤ Requisition/PMR</li> <li>➤ Purchase order</li> <li>➤ Approved MPS/QCP-ITP</li> <li>➤ Technical agreements between purchaser and manufacturer</li> <li>➤ Material/Mill Certificates</li> <li>➤ Manufacturer specification/procedure/data sheet</li> <li>➤ Including all WPSs/PQRs, progress inspection reports, NDT qualification reports, NDT reports, VT reports, mechanical &amp; chemical reports, Heat treatment reports, hydrostatic test reports, HIC &amp; SSC reports and other special, daily or laboratory test reports.</li> <li>➤ Deviations (NCR)</li> <li>➤ Calibration List</li> <li>➤ Traceable packing list</li>   <li>➤ Manufacturer Certificates (Consistency of inspection and test reports and traceability cards positive results of all tests and check steps)</li> <li>➤ Owner inspector Release Note</li> <li>➤ Inspection Certificate by owner inspector</li> <li>➤ Remarks</li> </ul>	<p><b>Production</b></p>		
<p><b>11.2 : Traceability</b></p> <p><b>For all pipe</b></p>	<p>This section shall include minimum requirements as follow :</p> <ul style="list-style-type: none"> <li>➤ Reference document: (Standard, Procedure...)</li> <li>➤ Equipment and method:</li> <li>➤ Traceability by heat number and lot number shall be maintained until the finished product.</li> <li>➤ Heat number and lot number shall be traceable on all the inspection and testing reports/charts.</li> <li>➤ Traceability shall be maintained on all the manufacturing processes, according to that, any movement for the pipes between different mills shall be accompanied with tally lists showing all information concerning traceability.</li> <li>➤ Produced reports/Doc: (Table, Chart, Data...).</li> <li>➤ Remarks :</li> </ul>	<p><b>Production</b></p>		

**12. ANNEX I: Manufacturing Process Chart of Pipe**

**13. ANNEX II: Heat treatment Process Chart of Pipe**

**14. ANNEX III: Welding Procedure Specification (WPS) for Welded pipe**

**15. ANNEX IV: Procedure Qualification Record (PQR) for Welded pipe**