

GENERAL STANDARD

FOR

MASKS AND BREATHING APPARATUS

ORIGINAL EDITION

MAR. 1996

This standard specification is reviewed and updated by the relevant technical committee on Oct. 2000. The approved modifications are included in the present issue of IPS.

CONTENTS :	PAGE No.
0. INTRODUCTION	4
1. SCOPE	5
2. REFERENCES	5
3. DEFINITIONS AND TERMINOLOGY	6
4. UNITS	7
 PART I MATERIALS	
5. MASKS AND RESPIRATORY EQUIPMENT (BREATHING APPARATUS).....	8
5.1 General	8
5.2 Selection of Breathing Apparatus	10
6. RESPIRATORS FOR DUSTS AND GASES	11
6.1 Filtering Facepiece Dust Respirators	12
6.2 High Efficiency Dust Respirators	12
6.3 Positive Pressure Dust Respirators	13
6.4 Positive Pressure Powered Dust Hood and Blouses	15
6.5 Gas Respirators Canister Type	17
6.6 Gas Respirators, Cartridge Type	18
7. FRESH AIR HOSE AND COMPRESSED AIR LINE BREATHING APPARATUS.....	19
7.1 Fresh Air Hose Apparatus.....	19
7.2 Materials.....	21
7.3 Strength	21
7.4 Separation of Parts	21
7.5 Adjustable Parts.....	21
7.6 Leak Tightness	21
7.7 Cleaning and Decontamination	21
7.8 Facepiece	21
7.9 Half-Masks	22
7.10 Mouthpiece	22
7.11 Noseclip	22
7.12 Head Harness	22
7.13 Air Hood or Blouse	22
7.14 Inhalation and Exhalation Valves	23
7.15 Demand Valve.....	23
7.16 Flow Control Valve.....	23
7.17 Breathing Tubes.....	23
7.18 Harness or Belt.....	23
7.19 Condition of the Inhaled Air (Carbon Dioxide Content)	23
7.20 Resistance to Breathing.....	24
7.21 Comfort	24
7.22 Temperature	24
7.23 Requirements for Fresh Air Hose Apparatus.....	24
7.24 Marking	25
7.25 Instruction.....	25
7.26 Certification	26

8. SELF CONTAINED BREATHING APPARATUS (SCBA)	26
8.1 General	26
8.2 Closed Circuit SCBA	26
8.3 Materials and Design	26
8.4 Tests and Certification	29
8.5 Marking	29
8.6 Instructions	30
9. OPEN CIRCUIT - SCBA	30
9.1 General	30
9.2 Requirements	30
9.3 Performance	31
9.4 Protection Against Particulate Matters	31
9.5 High Pressure Parts	32
9.6 Air Cylinders	32
9.7 Cylinder Valves	32
9.8 Cylinder Valve Connection (Valve Outlet)	32
9.9 Pressure Reducer	32
9.10 Pressure Gage	32
9.11 Warning Device	33
9.12 Flexible Hoses and Tubes	33
9.13 Lung Governed Demand Valve	33
9.14 Adjustable Parts	34
9.15 Facepiece	34
9.16 Breathing Resistance	34
9.17 Compatibility to Skin	34
9.18 Tests and Certification	35
9.19 Instructions for Maintenance and Storage	35
9.20 Marking	35
10. OPEN CIRCUIT ESCAPE SCBA	36
10.1 General	36
10.2 Requirements	36
10.3 Instructions	36
10.4 Marking	36
10.5 Test and Certification	37
11. VENTILATORY RESUSCITATORS	37
11.1 General	37
11.2 Dimension	37
11.3 The Mass	37
11.4 Performance Requirement	37
11.5 Testing and Certification	38
11.6 Marking	39
11.7 Information to be Provided by the Manufacturer	39
 PART II SELECTION, USE, INSPECTION AND MAINTENANCE	
12. SELECTION OF RESPIRATORY PROTECTIVE EQUIPMENT (see Fig. 5)	41
12.1 General	41
12.2 Severity and Location of the Hazard	41

12.3 Work Requirements and Conditions	41
13. USE OF RESPIRATORY PROTECTIVE EQUIPMENT	43
13.1 General	43
13.2 Test for Fit of Facepiece	43
13.3 Use in Low Temperatures	44
13.4 Use in High Temperatures	44
13.5 Use of Dust Canister and Cartridge Respirators	44
13.6 Use of Air Line Breathing Apparatus	45
13.7 Use of Self-Contained Breathing Apparatus	47
14. CARE AND MAINTENANCE OF RESPIRATORY PROTECTIVE EQUIPMENT	47
14.1 General	47
14.2 Cleaning and Decontamination	47
15. SPECIAL PROBLEMS	48
15.1 Beards	48
15.2 Corrective Spectacles and Protective Eyewear	49
15.3 Communication	49
16. INSPECTION, CARE AND MAINTENANCE OF RESPIRATORY EQUIPMENT	49
16.1 General	49
16.2 Respiratory Equipment	49
16.3 Canister and Cartridges	50
16.4 Atmosphere Air Supplied Respirator	51
16.5 Self-Contained Breathing Apparatus	51
16.6 Demand Regulators, Pressure Reducing Valves and Manifolds	54
16.7 Pressure Gages	55
16.8 Flexible Hoses	55
16.9 Rubber, Fabric and Plastic Components	56
16.10 Underwater Breathing Apparatus	56
 APPENDICES:	
APPENDIX A COMPRESSED AIR FOR HUMAN RESPIRATION	58
APPENDIX B AIR LINE RESPIRATOR	59
APPENDIX C DIAGRAM OF AIR SUPPLIED SUIT FOR USE IN CORROSIVE CHEMICAL ATMOSPHERES	60
 FIGURES	 62

0. INTRODUCTION

Respiratory protective equipment will either filter the contaminated atmosphere or supply clean air from other sources.

Following devices are applied for breathing:

- Mouth piece and nose-clip;
- half mask covering the nose and mouth;
- full face piece covering the eye, nose and mouth;
- hood covering the head down to the shoulders, or a blouse covering the head and body down to waist and wrists (see also [IPS-E-SF-300](#) for more details).

For selection of proper equipment the following points must be considered:

- The nature of hazardous operation of process;
- the type of air contaminant including its physical properties, physiological effects on the body and its concentration;
- the period of time for which respiratory protection have to be used;
- the location of hazard area to be considered with the distance of uncontaminated respirable area;
- the state of health of personnel involved;
- the functional and physical characteristics of respiratory protective devices.

The supervisor shall be aware of the classes of hazards for which a given type of respiratory equipment is approved to be used and shall not permit its use for protection against hazards for which it is not designed.

Employees must realize that failure to wear the appropriate respiratory equipment will endanger their lives, and only those with physical condition shall be prevented from using and entering the environment presenting respiratory hazards.

Training is of vital importance in the operation and maintenance of equipment.

1. SCOPE

This Standard specification is complied in two parts:

Part I: Covers the minimum requirements for material purchasing and using all types of masks and respiratory equipment as well as ventilatory resuscitator.

Part II: Gives the minimum requirements for selection, inspection and maintenance of appropriate various devices of the equipment.

Note:

This standard specification is reviewed and updated by the relevant technical committee on Oct. 2000. The approved modifications by T.C. were sent to IPS users as amendment No. 1 by circular No 126 on Oct. 2000. These modifications are included in the present issue of IPS.

2. REFERENCES

Throughout this Standard the following dated and undated standards/codes are referred to. These referenced documents shall, to the extent specified herein, form a part of this standard. For dated references, the edition cited applies. The applicability of changes in dated references that occur after the cited date shall be mutually agreed upon by the Company and the Vendor. For undated references, the latest edition of the referenced documents (including any supplements and amendments) applies.

IPS (IRANIAN PETROLEUM STANDARD)

[IPS-E-SF-300](#) "Application of Breathing Apparatus in Safety and Fire Fighting"

BSI (BRITISH STANDARD INSTITUTION)

BS 4667: (1974-1982), Parts 1, 2, 3, 4 and 5	"Specification for Breathing Apparatus"
BS 7355 (1990) EN 136	"Full Face Mask for Respiratory Protective Devices"
BS 7356 (1990) EN 140	"Half Masks and Quarter Mask"
BS 6016 (1980)	"Specification for Filtering Face Piece Dust Respirators"
BS 2091 (1969)	"Specification for Respirators for Protection Against Harmful Dusts, Gases and Scheduled Agricultural Chemicals"
BS 4275 (1974)	"Recommendations for the Selection, Use and Maintenance of Respiratory Protective Equipment"
BS 6850 (1987)	"Specification for Ventilatory Resuscitators"

NFC (NATIONAL FIRE CODES) NFPA

NFC (1991), Chapter 1 to 4

ISO (INTERNATIONAL ORGANIZATION FOR STANDARDIZATION)

ISO-8382 (1988), "Resuscitators Intended for Use with Humans"

(Appendices A to K)

3. DEFINITIONS AND TERMINOLOGY

3.1 Breathing Apparatus

An apparatus which enable the wearer to breath independently the immediate atmosphere with limits set out in this Standard.

3.2 Breathing Tube

A flexible tube through which air or oxygen flows to the face piece of a respirator or breathing apparatus.

3.3 Compressed Air Line Apparatus

An apparatus by which the wearer is supplied from a source of compressed air.

3.4 Contaminant

Harmful or nuisance dusts and gases.

3.5 Effective Duration

The time for which the apparatus can be expected to function satisfactorily. This time will be equal to the working duration plus a reserve period of at last 10 minutes for apparatus of less than 45 minutes working duration and 15 minutes for working duration between 45 and 75 minutes.

3.6 Escape Breathing Apparatus

The apparatus which is intended for escape purpose only from irrespirable atmosphere.

3.7 Facepiece

A mask fitting to the face covering the nose and mouth. There are two types:

- Half mask (or nasal facepiece) covering the nose and mouth.
- Full face piece covering the eyes nose and mouth.

3.8 Faceseal

A flexible lip or pneumatic cushion sealing the facepiece to the face.

3.9 Fresh Air Hose Apparatus

Apparatus in which air is drawn from a fresh air source with or without the assistance of a blower.

3.10 Fume

Airborne particles usually less than a micrometer in size and sometime visible as a cloud or smoke.

3.11 Nuisance Dust Course

Non-toxic particles.

3.12 Open Circuit

Compressed air carried in the cylinder is fed through a demand valve and breathing tube to a full facepiece. Inhaled air passes through a non-return valve to the atmosphere.

3.13 Oxygen Deficiency

Air containing insufficient oxygen to support life.

3.14 Particulate

Occurring in the form of minute separate particles, such as dusts, fume and mist.

3.15 Pressure Reducer (Reducing Valve)

A device that reduces a high pressure to a normally constant low pressure.

3.16 Working Duration

The maximum period of time for which the apparatus should be used.

Note:

Further definitions are given in [IPS-E-SF-300](#).

4. UNITS

This Standard is based on International System of Units (SI), except where otherwise specified.

**PART I
MATERIALS**

5. MASKS AND RESPIRATORY EQUIPMENT (BREATHING APPARATUS)

5.1 General

5.1.1 Classification of respiratory equipment

There are two distinct methods of providing personal protection against contaminated atmosphere.

- a) By purifying the air breathed.
- b) By supplying air or oxygen from an uncontaminated source.

5.1.2 Classification of environment

The environment may be contaminated by particles and/or by gases and vapors. Oxygen deficiency may also occur. Temperature and humidity are also to be taken into consideration Fig. 1:

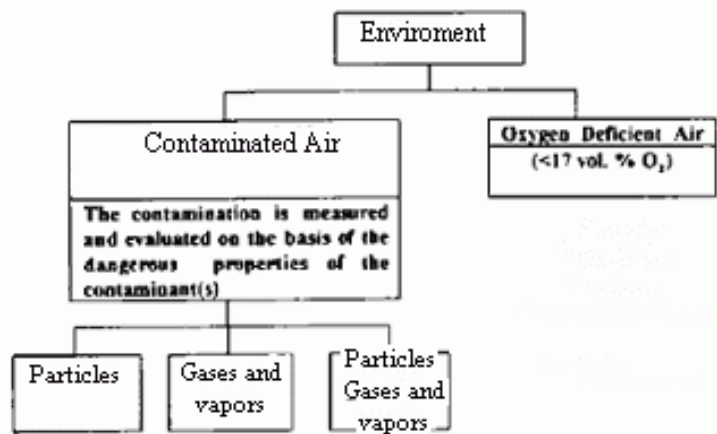

CLASSIFICATION OF THE ENVIRONMENT

Fig. 1

5.1.3 Classification of respiratory protective devices (see Fig. 2)

There are two distinct methods of providing personal respiratory protection against contaminated atmospheres:

- a) By purifying the air (filtering device).
- b) By supplying air or oxygen from an uncontaminated source (breathing apparatus).

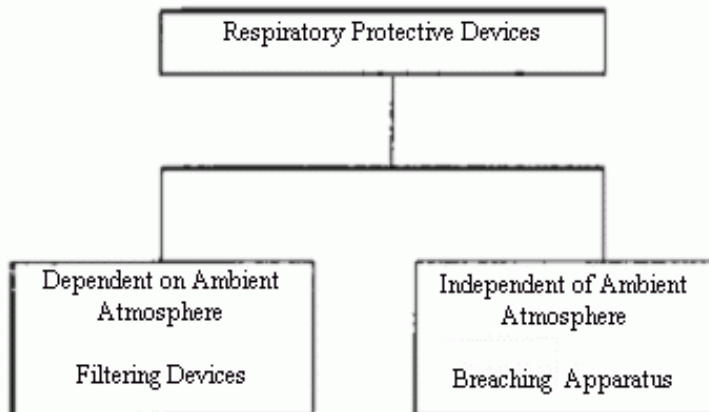

CLASSIFICATION OF RESPIRATORY PROTECTIVE DEVICES
 Fig. 2

5.1.3.1 Filtering devices (see Fig. 3)

The inhaled air passes through a filter to remove contaminants. The filtering devices can be unassisted or power assisted. Particle filters are divided into the following classes:

- Low efficiency filters
- Medium efficiency filters
- High efficiency filters

Medium and high efficiency filters are graded according to their ability to remove solid and liquid or solid particles only. Gas filters are divided into the following classes:

- Low capacity filters
- Medium capacity filters
- High capacity filters

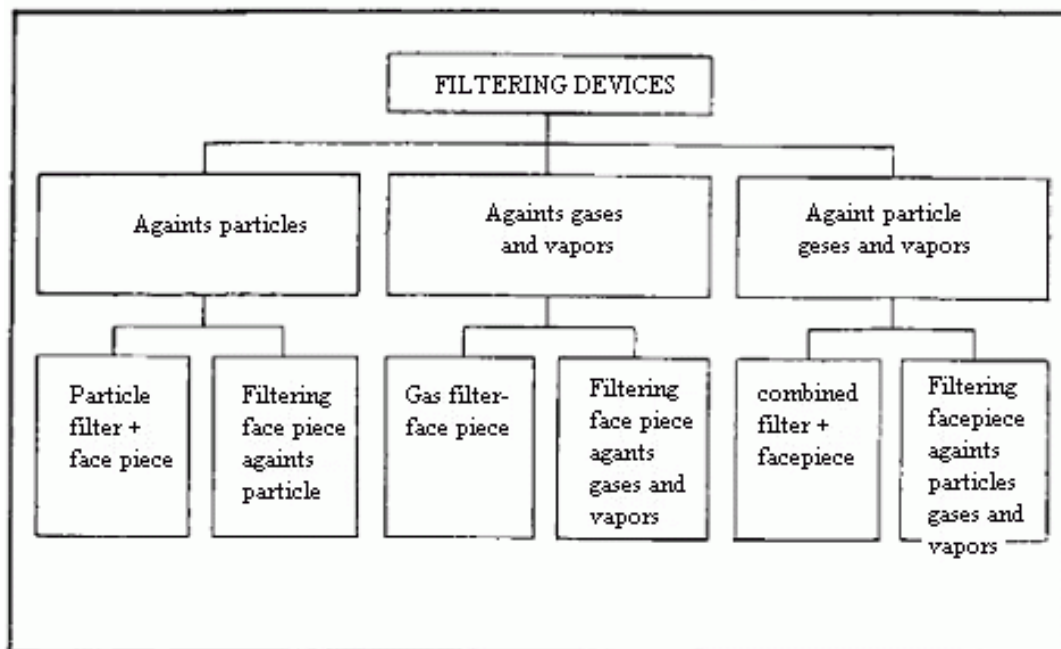

FILTERING DEVICES
 Fig. 3

5.1.3.2 Breathing apparatus

The main types of breathing apparatus are represented in Fig. 4.

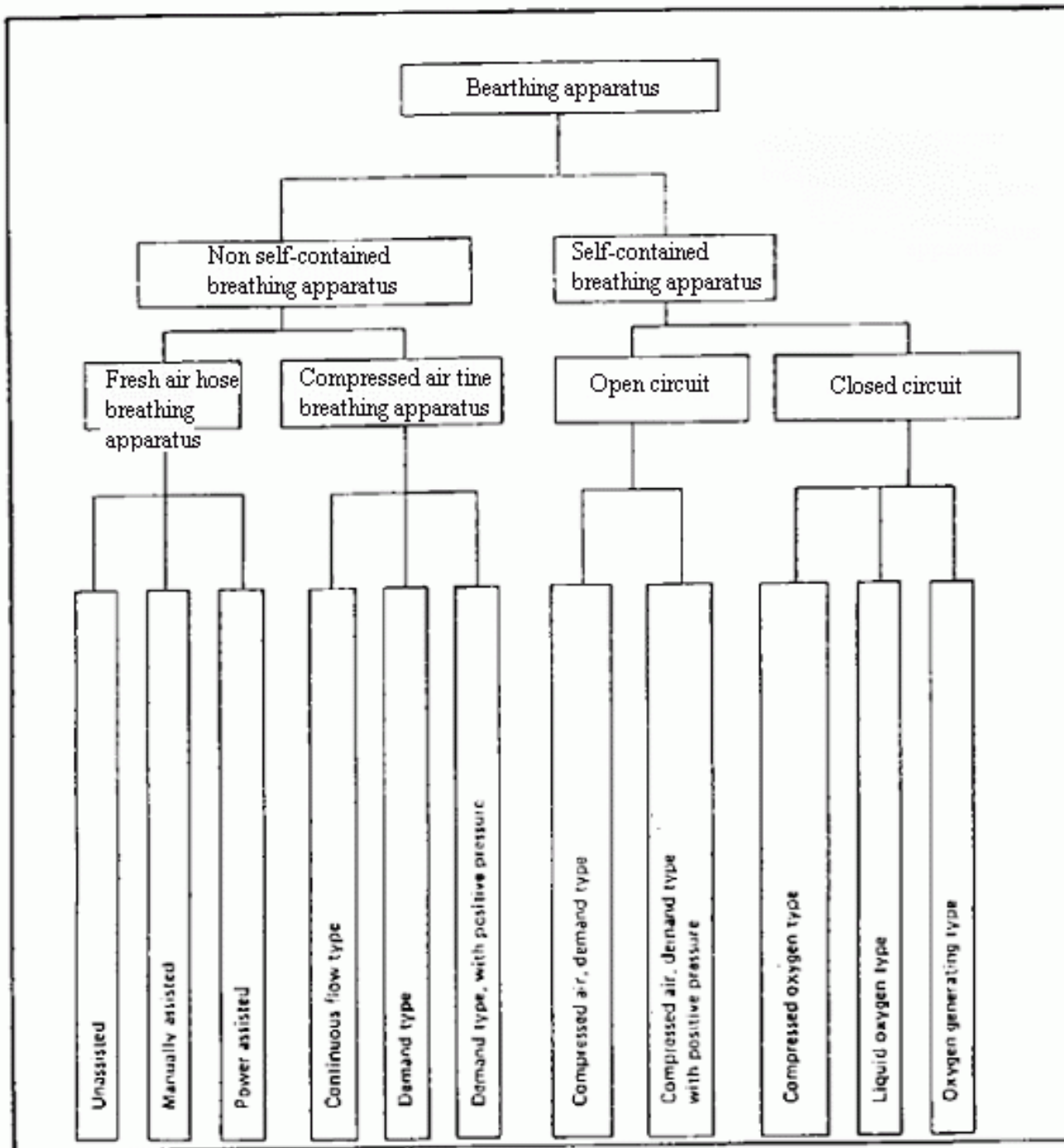

BREATHING APPARATUS

Fig. 4

5.2 Selection of Breathing Apparatus

Respiratory equipment must be regarded as emergency equipment or equipment of occasional use. Air contaminants range from relatively harmless to toxic dusts, vapors, mists, fumes, and gases that may be extremely harmful. Before respiratory equipment is ordered, the chemical and other

offending substances must be determined and the extend of hazard evaluated. Types of respiratory protective equipment are illustrated in Fig. 5.

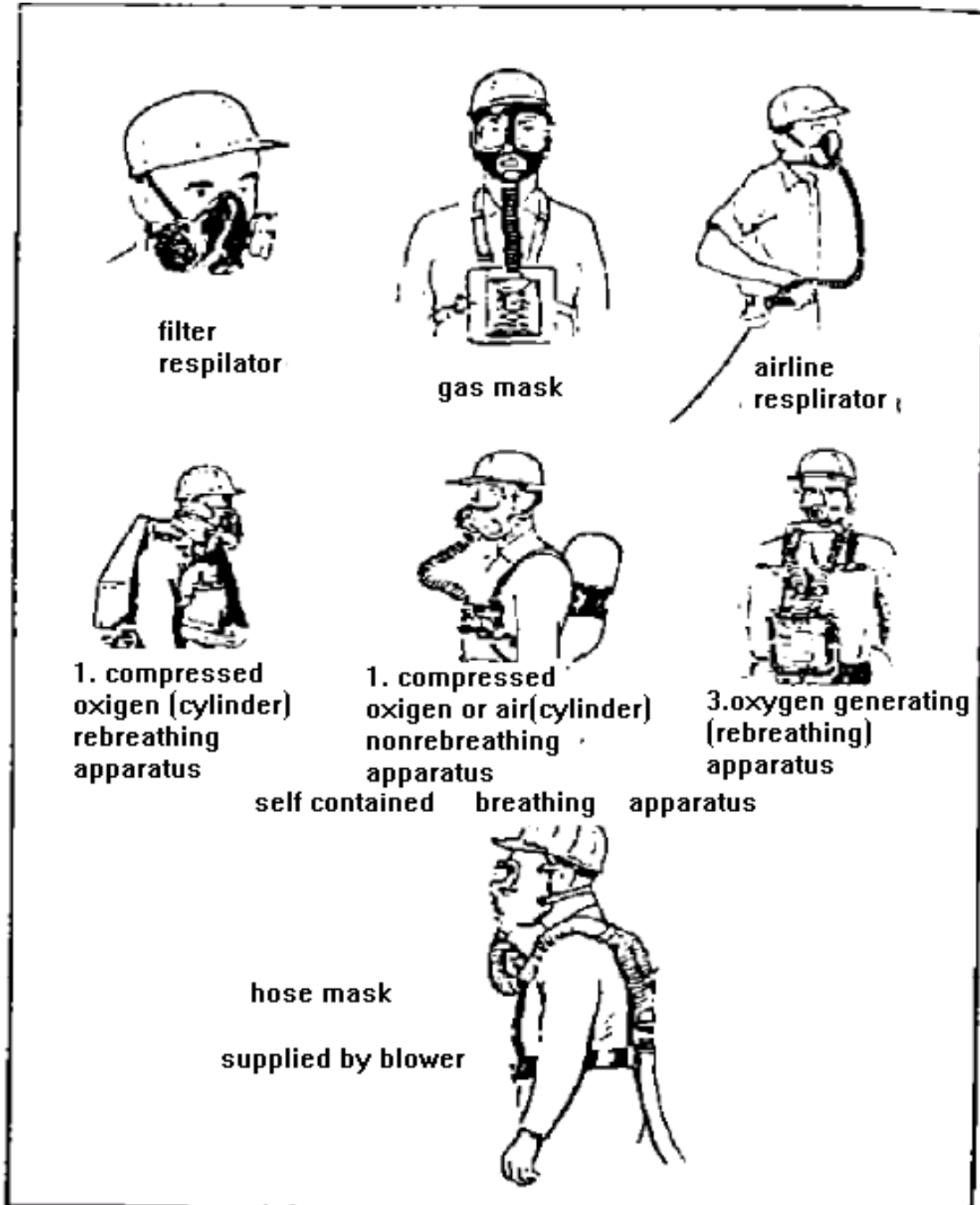

Fig. 5

6. RESPIRATORS FOR DUSTS AND GASES

Respirators for dusts and gases are filtering devices which are dependent on ambient atmosphere and are 3 types:

- a) Filtering against particles (Dust respirators);
- b) filtering against gases and vapors (Gas masks);
- c) filtering against particles, gases and vapors.

6.1 Filtering Facepiece Dust Respirators

6.1.1 Filtering dust respirator consists of the following:

- a) A facepiece covering at least the nose and mouth and consisting wholly or partly of filter materials through which the exhaled air may be discharged through the same materials or through an exhalation valve.
- b) A head harness which may or may not be adjustable to hold the facepiece securely in position on the head.

6.1.2 Construction

6.1.2.1 Materials used shall be suited to withstand handling and wear over the period for which the respirator is designed to be used. No materials of highly flammable nature of the same order such as cellulose nitrate shall be used.

6.1.2.2 Materials that may come into contact with the skin shall be non-staining, soft, pliable and shall not have harmful effects on the skin and no known toxic substances (e.g. asbestos) shall be used as filtering medium.

6.1.2.3 When fitted in accordance with the manufacturers instructions the complete respirator shall allow the correct wearing of safety helmet, ear defenders and spectacles or eye protectors.

6.1.2.4 The respirator shall be light in weight, cause minimal interference with vision, allow freedom of movement and be comfortable to wear.

6.1.3 Performance requirements

Respirators shall meet testing requirement in accordance with Clause 5 of BS 6016 and Appendices A, B, C and D or equivalent.

6.1.4 Marking

Respirators shall be marked legibly with the following:

- a) The name, trade mark or other means of identification;
- b) the number of official standard used;
- c) the size (if more than one size is available);
- d) the type;
- e) the month and the year of manufacture and probable shelf life.

6.2 High Efficiency Dust Respirators

6.2.1 Construction

The respirator shall meet the specification given in Clause 6.1.2.

6.2.2 Performance requirement

Assembled respirator shall be capable of passing the following tests:

a) Resistance test

1) Inhalator

The respirator is connected in an airtight manner to a hollow former of suitable shape, air is drawn from atmosphere through the filter at the rate of 85 LPM. The resistance imposed by the respirator shall not exceed 50 mm H₂O.

2) Exhalation

The assembled respirator is connected in an air tight manner to a hollow former of suitable shape; air is blown into the former at the rate of 85 LPM and passed through the respirator. The resistance imposed by the respirator shall not exceed 12.5 mm H₂O.

3) Valve leakage test

The suitable valve assembly when dry shall not have a leakage exceeding 30 ml/min when tested at constant suction head of 25 mm H₂O.

6.2.3 Marking

6.2.3.1 Facepiece

The respirator shall be marked legibly with the following:

- a) The name, trademark or other means of identification of the manufacturer;
- b) the number of official standard used;
- c) the year of manufacture.

6.3 Positive Pressure Dust Respirators

6.3.1 Construction

The respirator shall be constructed of suitable materials to withstand normal usage and exposure to extremes of environmental temperatures and humidity. The materials used shall be such that every component (except a battery when used) has a portable effective shelf life of at least 5 years, if properly stored and maintained. No materials of highly flammable nature of the same order such as cellulose nitrate shall be used.

Materials that may come into contact with skin shall be non-staining, soft and pliable and shall not contain known dermatitic substances.

Except for filters, all external surfaces and finishes shall be such that they will not so far as practicable retain toxic and radioactive particles.

6.3.2 Facepiece

6.3.2.1 The components of facepiece shall withstand a test underwater at an air pressure of 1.7 kN/m² and be proved free from leakage.

6.3.2.2 The facepiece shall be made in one size to fit all adult wearers. It shall be designed to meet the requirement of normal operating condition and tested in accordance with Appendix C of BS 2091. The facepiece shall cause the least possible interference with vision and freedom of

movement. Full facepiece shall have suitable and preferably replaceable eyeshield complying with optical requirement and shall permit the wearing of spectacles.

6.3.2.3 It shall be capable of withstanding respected cleaning and sterilizing by effective methods specified by the manufacturer.

6.3.2.4 The weight shall be as low as possible and symmetrically balanced to ensure the maximum retention of the face seal and minimize muscular strain, particularly when worn in circumstances involving vigorous head movement.

6.3.2.5 It shall reduce as far as practicable the proportion of air exhaled that can be rebreathed from within the mask itself.

6.3.3 Filter

6.3.3.1 High efficiency filters

The effectiveness of initial protection afforded by the filter system when assessed by method described in BS 4400 or equivalent shall be such that penetration at flow rate of 120 LPM shall not exceed 0.1%, in case of resin wool and resin felt filters, it shall not exceed 0.0 5%.

6.3.3.2 Standard filters

When similarly assessed, the effectiveness of the initial protection afforded by the filter system shall be such that the penetration at a flow rate of 120 LPM shall not exceed 5%, in the case of resin wool and resin felt filters the penetration shall not exceed 2%.

6.3.3.3 Substances (e.g. asbestos) shall not be used as a filtering medium.

6.3.3.4 Filter shall be designed to be irreversible.

6.3.3.5 Filters shall be readily replaceable and shall be capable of being fitted without edge leakage or other loss of efficiency.

6.3.3.6 The exhaled air shall pass directly to surrounding atmosphere through a non-return valve.

6.3.4 Harness

6.3.4.1 The head harness shall hold the facepiece firmly and comfortably in position. It shall be simply fitted and adjusted and easily removed for cleaning and decontamination

6.3.4.2 The head harness shall be adjustable and if consisting only of straps, these shall be adjustable and not less than 19 mm nominal width at the point of contact with the head and so designed that they have to be fully slackened on removing so ensuring that the wearer must readjust the straps before each occasion of use.

6.3.4.3 The head harness of half-mask if consisting only of straps, should not have less than 19 mm width at the point in contact with the head, with the adjustment in a position that will not interfere with the comfort or fit of safety helmet. After adjustment the harness shall permit the removal of the mask to a position round the mask and its replacement on the face, preferably without loss of adjustment.

6.3.5 Connecting fittings

6.3.5.1 The components of the respirator shall be designed to connect together by simple means so that individual component may be replaced by a simple operation without the use of special tools.

They shall be designed and marked to prevent incorrect assembly.

6.3.6 Performance requirement

6.3.6.1 Respirators shall be capable of meeting the requirement of BS 2091 Clause 3.4, for resistance of inhalation and exhalation, protection against dust, valve leakage, resistance to clogging by dust and humidity and resistance of filter to rough usage.

6.3.6.2 Full face masks shall be tested in accordance with BS 7355 EN 136 Clause 5, Testing.

6.3.6.3 Half masks and quarter masks shall be tested in accordance with BS 7356 EN 140 Clause 5, Testing.

6.3.7 Marking

6.3.7.1 All units of the same model shall be provided with a type identified by marking sub-assemblies and piece parts with considerable bearing on safety. The manufacturer shall be identified by name, trade mark, or other means of identification.

6.3.7.2 Where the reliable performance of piece parts may be affected by aging, means of identifying the date (at least the year) of manufacture shall be given.

6.3.7.3 The marking shall be provided with the following particulars:

- a) Serial numbers
- b) Year of manufacture

6.3.7.4 The marking shall be as clearly visible and as durable as possible. For parts which can not be marked, the relevant information shall be included in the instruction manual.

6.4 Positive Pressure Powered Dust Hood and Blouses

6.4.1 Construction

6.4.1.1 Hoods and blouses shall be constructed of suitable materials to withstand normal usage and exposure to extremes of environmental temperatures and humidity. The material used shall be such that every components (except a battery when used) have a probable effective shelf life of at least five years. No materials of highly flammable nature of the same order as cellulose nitrate shall be used.

6.4.1.2 Materials that may come into contact with the skin shall be non-staining, soft, pliable and shall not contain known dermatetic substances, except for filters all surfaces and finishes shall be such that they will not so far as practicable retain toxic or radioactive particles.

6.4.1.3 The equipment should be compact and shall cause the least possible interference with vision and freedom of movement. The weight of equipment should be as low as practicable and balanced to ensure comfort and minimize muscular strain, particularly when worn in circumstances involving vigorous movement.

6.4.2 Hood and blouses

6.4.2.1 The hood shall be made in one size to fit all adult wearers. It should have transparent area of viewing and be comfortable to wear.

6.4.2.2 The blouse shall be either of integral construction or sealed airtight with the hood and shall be made in sizes to fit adult wearers, with sleeve and waist openings elasticated or otherwise designed to construct the openings.

6.4.2.3 Hood and blouse shall be capable of withstanding without appreciable deterioration of repeated treatment by method described in Appendix D of BS 2091 or any methods of equivalent effectiveness specified by manufacturer.

6.4.3 Power pack

6.4.3.1 The power pack shall be capable of supplying air to the hood at a minimum rate of 120 LPM for a period of 4 hours, without replacement of the power source.

6.4.3.2 If a rechargeable battery is used it should be possible to recharge it completely within 14 hours and it shall be of non-spillable type, and if the battery is of a sealed type, a safe venting device shall be incorporated in the pack.

6.4.3.3 Harness

Any harness fitted shall hold the equipment firmly and comfortably in position. It shall be simply fitted and adjusted and easily removed for cleaning. So far as is practicable, it shall be constructed in such a way that contaminated garment may be removed easily without increasing local environmental contamination and without risk of transferring contamination to the wearer or other handler.

6.4.3.4 Connecting fittings

The components shall connect together by a simple means so that the individual component may be replaced by a simple operation without the use of special tools. They shall be designed or marked to prevent incorrect assembly. Any hose providing connection from power pack to the hood shall be kink resistant.

6.4.4 Performance requirement

The equipment shall be tested in accordance with Appendix C of BS 2091 or equivalent. Full masks, half and quarter mask shall be tested in accordance with BS 7355 EN 136 Clause 5 and BS 7356 EN 140 Clause 5.

6.4.5 Marking

The equipment shall be marked as follows:

6.4.5.1 Marking on the hood and blouse

- a) The name, trade mark or other means of identification of manufacturer.
- b) The number of official standard used.

6.4.5.2 Marking on supplying container

- a) The year of manufacture of the hood and blouse.

6.4.5.3 Marking on the filter

- a) The name, trade mark or other means of identification of the manufacturer.

- b) The number of official standard used.
- c) The year of manufacture.

6.5 Gas Respirators Canister Type

6.5.1 Construction

Gas respirators (canister type) are designed to protect the wearer from gases listed in Tables 3 and 4 of [IPS-E-SF-300](#). The life of canister is also given in term of the time of exposure at the maximum concentration and allowance must be made for facepiece leakage.

6.5.2 Performance requirement

6.5.2.1 Gas respirators canister type shall be tested in accordance with Clause 4-5 of BS 2091 consisting of tests for facepiece, valve leakage, resistance of canister to rough usage and performance.

6.5.2.2 The canisters listed in Table 4 of [IPS-E-SF-300](#) shall be tested with the test gases, test concentration and minimum exposure mentioned in absorption test column of the table.

6.5.3 Marking

Respirators dealt with this section of standard shall be marked with the following particulars:

6.5.3.1 Marking on the facepiece

- a) The name, trade mark or other means of identification of manufacturer.
- b) The number of official standard used.

6.5.3.2 Marking on supplying container

The month and the year of manufacture shall be marked on the supplying container.

6.5.3.3 Marking on the breathing tube

The number of official standard used shall be marked on breathing tube.

6.5.3.4 Marking on the canister

- a) The name and trade mark or other means of identification of the manufacturer;
- b) the number of official standard used;
- c) the color marking shown in Tables 4, 5 of [IPS-E-SF-300](#) and the bands or stripes being at least 25 cm wide;
- d) a list of gases against which protection is given by the canister;
- e) the month and the year on which the canister was filled, and;
- f) a warning notice indicating limiting condition of use (i.e. maximum concentration percent and maximum exposure in minutes) and the words:

"Not for use in static tanks, enclosed places or any circumstances where a high concentration of gas is likely to be present or in atmosphere deficient in oxygen"

6.6 Gas Respirators, Cartridge Type

6.6.1 Design and construction

6.6.1.1 The design and construction of gas respirators (cartridge type) shall be such that to provide protection against low concentrations of certain relatively non-toxic gases.

6.6.1.2 The respirator shall consist of a facepiece held securely in position with a head harness and connected to a cartridge or cartridges containing absorbent or absorbent material, and arranged with valves so that all air inhaled by the wearer passes through the cartridges. The exhaled air shall pass directly to the surrounding atmosphere through a nonreturn valve(s). A particulate filter shall be incorporated and for some applications it is desirable that readily replaceable prefilters shall be available.

6.6.1.3 The cartridge shall be readily replaceable without the use of special tools, and shall be designed or marked to prevent incorrect assembly.

6.6.2 Fit

When tested the fit of the respirator shall ensure that leakage of the test contaminant between the facepiece and the wearer's face does not exceed a mean value of 5% for the 10 test subjects.

6.6.3 Performance requirements

Respirators shall be capable of meeting performance requirements in accordance with BSI 2091 Clause 5.3 or equivalent.

6.6.4 Tests and certification

6.6.4.1 Respirators shall be tested and certified by manufacturer. The tests shall cover the following in accordance with BSI 2091 Appendices A, B, C, D & E.

- a) Static leakage of outlet valves;
- b) dust clogging test;
- c) face seal leakage test;
- d) sterilization test for material and construction;
- e) rough usage test.

6.6.5 Marking

Respirators dealt within this section shall be marked with the following particulars:

6.6.5.1 Marking on the facepiece

The facepiece shall be marked with:

- a) The name, trade mark or other means of identification of the manufacturer;
- b) the number of official standard used.

6.6.5.2 Marking on the supplying container

The month and year of manufacture shall be marked on the supplying container.

6.6.5.3 Markings on the cartridge

The cartridge shall be marked with:

- a) The name, trade mark or other means of identification of the manufacturer;
- b) the number of official standard used;
- c) an indication of the gases against which protection is given by the cartridge, e.g. Table 5 of [IPS-E-SF-300](#);
- e) the month and year in which the cartridge was filled;
- f) a warning notice indicating conditions of use, e.g. "for low concentration of non-toxic substances".

6.6.5.4 Markings on the cartridge container

The cartridge container shall be marked with the following words:

"Not for use in static tanks, enclosed places or in any circumstances where a high concentration of gas is likely to be present, or in atmospheres deficient in oxygen."

6.6.6 Combination respirators

Combination chemical and mechanical filter respirators utilize dust, mist or fume filters with chemical cartridge for dual or multiple exposure. Normally, the dust filter clogs up before the chemical cartridge is exhausted. It is therefore preferable to use respirators with independently replaceable filters. The combination respirator is well suited for spray painting and welding.

Note:

It is recommended that chemical cartridge and canister respirators shall not be used in any emergency cases.

7. FRESH AIR HOSE AND COMPRESSED AIR LINE BREATHING APPARATUS

The following are five methods of operation:

- a) Fresh air hose apparatus, without blower
 - i) " " " " with hand blower
 - ii) " " " " with motor operated blower
 - iii) Compressed air line apparatus (constant flow type)
 - iv) " " " " (demand type)

All above apparatuses consist of a full facepiece or mouth piece with nose clip.

7.1 Fresh Air Hose Apparatus

Fresh air hose apparatus is provided with a valve system connected by an air hose to uncontaminated air which is drawn through a hose of adequate diameter by the breathing action of the wearer. The hose shall not exceed 9 m in length and DN-20 ($\frac{3}{4}$ inch) diameter.

7.1.1 Fresh air hose apparatus (with hand operated blower)

The apparatus is connected by an air hose to uncontaminated air is forced through a hose of adequate diameter by a hand operated blower, and through which the wearer can inhale in and in case of emergency whether or not the blower is operated the wearer have a chance to leave contaminated area. The hose should not exceed 35 m in length (see Appendix B, Fig. B.1).

When the flow of air along the tube is mechanically assisted, the inward leakage of contaminated atmosphere is greatly reduced. If the air hose is relatively short, restricts movement, and necessitates return to a respirable atmosphere along the route of entry. The size of hose should be 9 m in length and DN-20 ($\frac{3}{4}$ inch) diameter. Care is necessary to prevent damage to the hose.

7.1.1.1 Fresh air hose without blower

Air suitable for respiration is drawn by breathing action of the wearer. The hose is anchored and fitted with a suitable device to prevent entry of course particles.

7.1.2 Fresh air hose apparatus (with motor operated blower)

Uncontaminated air is forced through a hose of adequate diameter by a motor operated blower at a flow rate of minimum 120 LPM and through which the wearer can inhale in and in case of an emergency the last part of Clause 7.1.1 can be followed:

In this type of apparatus a continuous flow of air suitable for respiration is forced through a hose by a motor operated blower. A full facepiece, a half mask or a mouthpiece and nose-clip may be used. The hose length on no account shall exceed 35 m. If a facepiece is used and the blower fails, negative pressure will exist in the facepiece during inhalation although the apparatus will continue to provide some protection while the wearer leaves the hazard area.

7.1.3 Air line hose mask connected to a source of respirable air under pressure (see Appendix B, Fig. B.2)

This apparatus provides compressed air suitable for respiration through a flexible air hose attached to a compressed air line. Filter may be included in the airline to remove undesirable contaminants and suitable valves are used to control air supply (see Appendix B). The apparatus can be used only where a suitable continuous supply of clean compressed air is available either from a compressor system or from cylinders. Flexible hose should not exceed 90 m, and whilst this type allows more movement than the fresh air hose apparatus, its restrictions are basically the same. Care should be taken in the choice of tubing to be used in very high or very low ambient temperatures. No protection is provided if the air supply fails unless special provision is made.

7.1.4 Compressed air line apparatus (constant flow type) see Appendix C

The apparatus may consist of an air hood or blouse connected to a supply of breathable air fed continuously to the wearer. The airflow is regulated by a flow control valve from a source of compressed air.

The most extreme condition requiring respiratory equipment is that in which rescue and emergency repair work must be done in atmospheres extremely corrosive to the skin and mucous membranes, in addition to being actually poisonous and immediately hazardous to life.

Where high ambient temperature may be encountered or where body heat may built up, the hose line supplying the air should be connected to the suit itself, as well as to the helmet and personal air conditioning devices utilizing a vortex tube should be used.

7.1.5 Compressed air line apparatus (demand valve type)

The apparatus consists of a full facepiece connected to a demand valve that admits breathable air to the wearer when he inhales and closes when exhales. An air line connects the wearer to a supply of compressed air.

7.2 Materials

7.2.1 All materials used in the construction shall have adequate mechanical strength, durability and resistance to deterioration by heat, and, where applicable, by contact with sea water. Such materials shall be antistatic and fire resistant as far as is practicable.

7.2.2 Exposed parts of the apparatus shall not be made of magnesium, titanium, aluminum or alloys containing such proportions of these metals as will, on impact, give rise to frictional sparks capable of igniting flammable gas mixtures.

7.2.3 Materials that may come into contact with the skin shall be non-staining, soft, pliable and shall not contain known dermatetic substances.

7.3 Strength

The apparatus shall be sufficiently robust to withstand the rough usage it is likely to receive in service.

7.4 Separation of Parts

The design and construction of the apparatus shall permit its component parts to be readily separated for cleaning, examination and testing. The couplings required to achieve this shall be readily connected and secured, where possible by hand; any means for sealing used shall be retained in position when the joints and couplings are disconnected during normal maintenance.

7.5 Adjustable Parts

All parts requiring manipulation by the wearer shall be readily accessible and easily distinguishable from one another by touch. All adjustable parts and controls shall be constructed so that their adjustment is not liable to accidental alteration during use.

7.6 Leak Tightness

The apparatus shall be so designed and constructed as to prevent the ingress of the external atmosphere within the limits set out in this standard at any place other than the fresh air inlet.

7.7 Cleaning and Decontamination

The design of the apparatus shall be such that to facilitate cleaning. All exposed surfaces shall be capable of withstanding treatment without appreciable deterioration.

7.8 Facepiece

Where facepieces are used, they shall be designed to meet the following requirements.

7.8.1 For leak tightness see Clause 5-2-3 of BS 4667: Part 3.

7.8.2 Facepieces shall cover the eyes, nose, mouth and shall provide adequate sealing on the face of the wearer of the breathing apparatus against the outside gas, when the skin is dry or moist, when the head is moved and when the wearer is speaking.

7.8.3 Facepieces shall fit against the contours of the face so that when tested the inward leakage of the test contaminant between the facepiece and the wearer's face shall not exceed a value of 0.05% of the inhaled air for any one of the ten test subjects. It is unlikely that this requirement will be met by wearers with beards or with spectacles having side arms.

7.8.4 Facepieces shall be light in weight and comfortable to wear for long periods. The weight

should be symmetrically balanced to ensure the maximum retention of the faceseal and to minimize muscular strain, particularly when worn in circumstances involving vigorous movements.

7.8.5 Facepieces shall have suitable and, preferably, replaceable eyepieces or eyeshields.

7.8.6 Facepieces shall be secured to the face by means of an adjustable and replaceable head harness and they shall be fitted with a strap to support them when not being worn.

7.8.7 Means for speech transmission shall be incorporated.

7.8.8 The manufacturer shall provide means to reduce misting of the eyepieces or eyeshields so that vision is not interfered with.

7.9 Half-Masks

Where half-masks are used they shall comply with the requirements specified in Clause 5 of BS 7356 EN 140 except that they shall not cover the eyes and the inward leakage test is carried out when air is being supplied at a flow of 120 LPM.

7.10 Mouthpiece

If the apparatus is fitted with a mouthpiece it shall be designed to provide a reliable seal with the mouth and shall be secured against accidental displacement by means of an adjustable head harness. It is recommended that a plug or cover be provided to close the orifice of the mouthpiece when not in use.

7.11 Noseclip

A noseclip shall be provided if a mouthpiece is used and should be designed to afford maximum security against accidental displacement; it should not slip when the nose becomes moist with perspiration, and suitable means shall be provided for attaching it to the apparatus to prevent loss.

7.12 Head Harness

7.12.1 The head harness shall hold the facepiece, half-mask or mouthpiece firmly and comfortably in position. It shall be simply fitted and adjusted and shall be capable of ready cleaning and decontamination. Any fabric used in the construction of a head harness shall be resistant to shrinkage.

7.12.2 The head harness shall be adjustable and, if consisting only of straps, these shall be adjustable and not less than 19 mm (nominal) width at the points in contact with the head, and designed so as to ensure that the wearer must readjust the straps before each occasion of use. The means of adjustment shall be slip-proof.

7.13 Air Hood or Blouse

7.13.1 The air hood or blouse shall be light in weight and comfortable to wear for long periods. It shall have a transparent area affording a good forward view.

7.13.2 A minimum air supply shall be specified by the manufacturer (which shall be not less than 120 LPM) the inward leakage of the external atmosphere into the hood or blouse shall not exceed a value of 0.1%.

7.14 Inhalation and Exhalation Valves

7.14.1 In fresh air hose apparatus (lung-operated or with hand blower) an inhalation valve shall be fitted in such a position as to minimize the rebreathing of expired air. Where a breathing bag or other flexible reservoir is fitted the inhalation valve shall be located between the bag or reservoir and the mouthpiece or facepiece.

7.14.2 All apparatus except air hoods and blouses shall be provided with an exhalation valve to allow the escape of exhaled air and any excess air delivered by the air supply, and it shall be capable of being operated automatically by the pressure in the breathing circuit. The exhalation valve shall be designed so that inward leakage of the external atmosphere shall not exceed 0.0025% when the moist valve is tested. The valve shall be protected against dirt and mechanical damage.

7.14.3 When it is possible in these types of apparatus for the pressure in the facepiece to fall below atmospheric in normal use, the exhalation valve shall be shrouded or shall include an additional non-return valve or other device that may be necessary.

7.14.4 The design of valve assemblies shall be such that valve discs or the assemblies can be readily replaced; it shall not be possible to fit an inhalation valve assembly in the expiratory circuit or an exhalation valve assembly in the inspiratory circuit.

7.15 Demand Valve

A demand valve, when fitted, shall be connected directly or by a nonkinkable hose to the facepiece. When in any position the demand valve shall operate at an inlet pressure between 345 kN/m² and 1035 kN/m² and shall be capable of supplying air at a minimum flow of 120 LPM.

7.16 Flow Control Valve

The flow control valve when fitted shall be sited on the waistbelt or harness in a position where it can be easily adjusted. It shall provide an adequate flow to the facepiece or hood at all stated supply pressures and the valve in the 'fully closed' position shall pass at least 57 LPM at the minimum stated supply pressure.

7.17 Breathing Tubes

If the air supply hose is of the low pressure type, a flexible, nonkinking breathing tube (tubes) shall be used to connect it to the mouthpiece of facepiece and permit free head movement to the wearer.

7.18 Harness or Belt

7.18.1 A harness or belt shall be provided to prevent a pull on the breathing tube or on the mouthpiece, facepiece or air hood. Buckles shall be so constructed that once adjusted they will not slip.

7.18.2 The attachment connecting the hose to the harness or belt shall be so designed and constructed as to withstand a pull of 1000 N in all directions.

7.18.3 Any fabric used in the construction of a body harness shall be resistant to shrinkage.

7.19 Condition of the Inhaled Air (Carbon Dioxide Content)

7.19.1 When the apparatus using a mouthpiece is tested, the carbon dioxide content of the inhaled air (including dead space effects) shall not exceed 1.0% (by volume).

7.19.2 When the apparatus with an air flow of less than 120 LPM using a facepiece or half-mask is

tested, the carbon dioxide content of the inhaled air (including dead space effects) shall not exceed 1.5% (by volume).

7.20 Resistance to Breathing

7.20.1 With the air supply system working at any flow chosen by the testing authority but within its designed range of pressures and air flow, or with a blower operated in such a way that the operator would not become unduly fatigued after 30 min, or with the fresh air hose alone (if not supplied with blower or bellows), then with the maximum length of tube for which the apparatus has been submitted for approval, half of it coiled to an inside diameter of 500 mm, neither the inspiratory nor the expiratory side of the apparatus shall have a dynamic resistance greater than 50 mm H₂O.

7.20.2 If any of the air supply systems detailed in 7.23.1 ceases to operate, the wearer shall still be able to inhale through the tube without undue distress. This provision shall be satisfied if the total inspiratory resistance, with the air supply system inoperative but not disconnected and with the maximum length of the tube for which the apparatus has been submitted for approval, is not greater than 125 mm H₂O at a continuous air flow of 85 LPM.

7.21 Comfort

When tested the apparatus shall be such that it may be worn without avoidable discomfort, that the wearers show no undue signs of strain attributable to wearing the apparatus, and that it impedes the wearer as little as possible when in a crouched position or when working in a confined space.

7.22 Temperature

Apparatus intended for use in low temperatures shall function satisfactorily.

7.23 Requirements for Fresh Air Hose Apparatus

7.23.1 Fresh air hose supply systems

7.23.1.1 With blower

Hand operated blowers shall be capable of being operated by one man without undue fatigue for at least 30 min.

7.23.1.2 Rotary type blowers shall be capable of maintaining a positive air pressure with either direction of rotation, or else be made to operate in one direction only. In the former case the direction of operation in which the blower delivers lesser volume of air against the designed working pressures shall be used in the tests. When motor operated blowers are used where flammable surroundings may arise it is essential that the suitability of the equipment for use in such surroundings be considered.

Note:

It is recommended that an air flow indicator to be provided at the blower to indicate the flow rate.

7.23.1.3 Without blower

The hose shall be fitted with a strainer at the free end to exclude debris. Provision shall be made for securely anchoring the free end of the hose and strainer so that it cannot be dragged into the contaminated atmosphere.

7.23.2 Low pressure hoses of fresh air supply

The hose of low pressure air supply shall meet the requirement of BS 4667 Clause 4.2 or equivalent.

7.23.3 High pressure tubing

High pressure tubing shall meet the requirement of Clause 5.2 BS 4667 or equivalent.

7.24 Marking**7.24.1 Marking in the facepiece, half mask, hood and blouse:**

- a) The name, trade mark or other identification of the manufacturer;
- b) for hood and blouse, the designed air flow in LPM;
- c) whether or not designed in low temperature.

7.24.2 Marking on hose

- a) The name, trade mark or other means of identification of the manufacturer;
- b) designed air flow in LPM;
- c) mark of heat resistant;
- d) the working pressure of high pressure hose.

7.24.3 Marking on the flow control

The maximum working pressure.

7.24.4 Marking on blower

- a) The name, trade mark or other means of identification of the manufacturer;
- b) designed air flow in LPM;
- c) the maximum length of air hose for which the blower is designed.

7.25 Instruction

Breathing apparatus shall be supplied and accompanied by up-dated instructions for maintenance and use. These instructions shall include the following informations:

- a) The size of the facepiece, half-mask, hood or blouse (if more than one size is available);
- b) for hoods and blouses, the designed air flow in LPM;
- c) whether or not designed for use in low temperatures;
- d) guidance on the fit of the facepiece, and adjustment of faceseal where relevant;
- e) for the hose of fresh air hose apparatus, the designed minimum air flow in LPM;
- f) for hoses, the words 'heat resistant';
- g) the working pressure of high pressure hose;
- h) the maximum and minimum working pressures of the flow control valve;
- i) for the blower, the designed minimum air flow in LPM;

- j) the maximum length of air hose for which the blower is designed;
- k) a warning that adequate protection may not be provided by the apparatus in certain highly toxic atmospheres and guidance is given in BS 4275;
- l) a warning that allowance should be made for the fact that it is likely that face seal fit will be adversely affected by spectacles, sideburns or beards;
- m) a warning that at very high work rates the pressure in the facepiece may become negative at peak inhalations.

7.26 Certification

Manufacturer shall inform in writing that all fresh air hose, and compressed air line apparatus have been tested and certified by recognized international organization and approval of the Company is obtained.

8. SELF CONTAINED BREATHING APPARATUS (SCBA)

8.1 General

SCBA are classified as:

- a) Closed circuit (recirculating)
- b) Open circuit (demand)

There are two types of closed circuit apparatus

- a) Oxygen generating type, in which oxygen generating chemicals in a container are activated by the moisture in the users expired breath.
- b) Compressed air or liquid oxygen type, which employs a contained or compressed or liquid oxygen.

8.2 Closed Circuit SCBA

Closed circuit SCBA is designed to enable man to work in irrespirable atmosphere for longer periods than are generally possible with the open circuit and with the greater freedom of movement than is allowed by air line types. The apparatus is designed and constructed so that exhaled air passes from facepiece or mouthpiece through a breathing tube into a purifier containing chemicals which absorb the exhaled carbon dioxide. Oxygen is fed into breathing circuit from a cylinder of compressed oxygen or from a liquid oxygen/air container. The oxygen and purified gases mixture are fed to the wearer who inhales from a breathing bag, and any excess gas is released through a relief valve.

8.3 Materials and Design

(See Clause 7.2) in addition to the following items:

8.3.1 Body harness

The body harness shall be designed to allow the user to don the apparatus quickly and easily without assistance and shall be adjustable for fit. Buckles fitted to waist and shoulder harness shall be so constructed that once adjusted they will not slip. Any fabric used in the construction of a body harness shall be resistant to shrinkage. For certain applications the body harness shall be detachable to permit water immersion testing, or the component parts shall not retain water. Where the body harness incorporates means for attachment of a lifeline, the harness, together with the snap hook, shall be capable of withstanding a drop test of 1 m when loaded to 75 kg.

8.3.2 Inhalation and exhalation valves

The design of valve assemblies shall be such that valve discs or the assemblies can be readily replaced; it shall not be possible to fit an inhalation valve assembly in the expiratory circuit or an exhalation valve assembly in the inspiratory circuit.

8.3.3 Relief valve

8.3.3.1 General

Breathing apparatus of the closed circuit type shall be provided with a relief valve operated automatically by the pressure in the breathing circuit and designed so that inward leakage of the external atmosphere shall not exceed 0.0025% when the moist valve is tested. The relief valve, which shall include an additional non-return valve, shall be protected against dirt and mechanical damage. Means shall be provided for sealing the relief valve to permit leak testing.

8.3.3.2 Performance characteristics of relief valve

- a) The opening pressure of the moist relief valve measured at a constant flow of 1 LPM shall be between 15 mm H₂O and 40 mm H₂O in any position of the valve.
- b) The flow resistance, at a constant flow of 300 LPM of that part of the expiratory breathing circuit between the relief valve and the breathing bag shall not be greater than the minimum opening pressure of the relief valve.
- c) In apparatus using liquid air or liquid oxygen, the resistance of the relief valve to an air flow of 100 LPM shall not exceed 50 mm H₂O in any position of the valve.
- d) In apparatus using compressed oxygen, the resistance of the relief valve to an air flow of 50 LPM shall not exceed 50 mm H₂O in any position of the valve.

8.3.4 Reducing valve or pressure reducer

8.3.4.1 In apparatus using a reducing valve or pressure reducer alone, i.e. without a supplementary lung-governed oxygen supply, the flow of oxygen shall not be less than 2 LPM for the effective duration of the apparatus except that for apparatus with a pressure reducer the oxygen flow during the reserve period may fall to not less than 1.8 LPM.

8.3.4.2 The flow of oxygen from a reducing valve of constant flow type shall remain constant to within 10% of the preset flow at all cylinder pressures above ten atmospheres.

8.3.4.3 The reducing valve, if adjustable, shall be provided with a suitable locking device to prevent accidental alteration of the oxygen supply.

8.3.5 Lung-Governed oxygen supply (demand valve)

8.3.5.1 The opening pressure of the lung-governed supply mechanism measured at a constant flow of 10 LPM shall not exceed 35 mm H₂O.

8.3.5.2 Apparatus operating with a lung-governed constant supply of less than 2.0 LPM, shall have an automatic scavenge device by means of which sufficient "air" is removed from the circuit to the outside to maintain an oxygen content of not less than 21%.

8.3.6 By-Pass valve

Apparatus equipped with a pressure reducer or a reducing valve and/or lung-governed valve, shall be provided with a manually operated by-pass valve of self-closing type, whereby the wearer can obtain a supply of oxygen at a flow of between 60 LPM and 300 LPM at all cylinder pressures

above 5000 kN/m² independently of the reducing valve or lunggoverned valve.

8.3.7 Pressure gage

8.3.7.1 Apparatus using compressed oxygen shall have a pressure gage. The gage shall incorporate a suitable blow-out release so that in event of an explosion or fracture of the pressure element of the gage, the blast will be away from the front. The gage shall have window of non-splintering glass or of clear plastics material.

8.3.7.2 An efficient valve shall be provided to isolate the gage and connections to it from the rest of the circuit.

8.3.7.3 The pressure gage shall be placed to enable the gas cylinder pressure to be read conveniently by the wearer.

8.3.7.4 The pressure gage shall incorporate a means of indicating an adequate warning period. This will vary according to users' requirements.

8.3.8 Warning device

Where apparatus using compressed oxygen has an audible warning device that operates when the cylinder pressure drops to a predetermined level to warn the wearer that he must withdraw immediately to fresh air, the device shall have the following characteristics:

- a) If operated by compressed oxygen, and average consumption of not more than 2 LPM.
- b) Operation shall begin when not more than 80% of the fully charged capacity of the cylinder has been used.
- c) A frequency of between 2500 Hz and 4000 Hz.
- d) Clear audibility to the wearer and those in his immediate vicinity until the pressure gage needle at least reaches the warning zone marked on the pressure gage.

8.3.9 Flexible tubes

Flexible tubes and fittings of the high pressure system shall be capable of withstanding without damage a test pressure of twice the maximum designed working pressure. It shall not be possible to fit a low pressure tube or hose into a higher pressure part of the circuit.

8.3.10 Gas cylinder and valve

8.3.10.1 Gas cylinders shall comply with specification approved by the Purchaser. Such approval may involve restrictions in application.

8.3.10.2 Cylinders shall be colored in accordance with [IPS-E-SF-300](#).

8.3.10.3 The main valve shall be so designed that the full pressure in the gas cylinder cannot be applied rapidly to other parts of the apparatus.

8.3.10.4 The valve shall be so designed that the valve spindle can not be completely unscrewed from the assembly during normal operation of the valve.

8.3.10.5 The valve shall be either lockable in the open position or designed so that it cannot be closed inadvertently by contact with a surface.

8.3.11 Oxygen supply

The total volume of oxygen available shall be sufficient to meet an average consumption of not less

than 2 LPM for the effective duration of the apparatus. In apparatus without a supplementary lung-governed oxygen supply an additional 10% capacity shall be provided to allow for the possible use of the by-pass valve.

8.3.12 Breathing bag

8.3.12.1 The breathing bag shall be made of strong, flexible material and shall be protected against collapse or damage by external agencies.

8.3.12.2 The breathing bag shall be reliably and tightly joined to the couplings. The coupling at the inhalation side shall be shaped in such a way that its opening cannot be closed by the bag itself.

8.3.12.3 In apparatus using compressed oxygen, the capacity of the breathing bag, when correctly fitted and with the casing closed, shall be at least 5 litres.

8.4 Tests and Certification

Closed circuit breathing apparatus shall be tested and certified by organization of testing accepted by the Company's authorities. Manufacturer shall supply testing certificates with the apparatus. The test shall cover the following:

- a) The capacity and function of breathing bag;
- b) condition of inhaled air;
- c) resistance to breathing air;
- d) comfort;
- e) durability of materials when subjected to cleaning and decontamination;
- f) inward leakage of facepiece;
- g) practical performance;
- h) laboratory performance tests;
- i) low temperature tests;
- j) test for inward leakage on relief valve.

8.5 Marking

Breathing apparatus manufactured in compliance with this Standard shall be marked with the following particulars.

8.5.1 Marking on the facepiece

- a) The name, trade mark or other means of identification of the manufacturer;
- b) the number of official Standard used.

8.5.2 Markings on the apparatus

- a) The name, trade mark or other means of identification of the manufacturer;
- b) the number and part of official Standard used;
- c) the working duration:
 - 1) with warning device;
 - 2) without warning device.

8.6 Instructions

Breathing apparatus manufactured in compliance with this Standard shall be supplied accompanied by dated instructions for maintenance and use which shall include where appropriate:

- a) Working duration;
- b) guidance on fit of facepiece, and adjustment of facesal where relevant;
- c) a warning that adequate protection may not be provided by the apparatus in certain highly toxic atmospheres and guidance;
- d) a warning that allowance should be made for the fact that it is likely that facesal fit will be adversely affected by spectacles, sideburns or beards;
- e) grain size of carbon dioxide absorbent.

9. OPEN CIRCUIT - SCBA

9.1 General

A self-contained open-circuit compressed air breathing apparatus is an apparatus which has a portable supply of compressed air and is independent of the ambient atmosphere.

Compressed air breathing apparatuses are designed and constructed to enable the wearer to breath air on demand from a high pressure air cylinder (or cylinders) either via a pressure reducer and a lung-governed demand valve or a lunggoverned demand valve connected to the facepiece. The exhaled air passes without recirculation from the facepiece via the exhalation valve to the ambient atmosphere.

Compressed air breathing apparatuses are classified according to the following effective air volume at a pressure of 1 bar absolute and a temperature of 20°C:

at least	600 L
at least	800 L
at least	1200 L
at least	1600 L
at least	2000 L

9.2 Requirements

9.2.1 Design

The apparatus shall be of simple and reliable construction and as compact as possible. The design of the apparatus shall be such as to allow its reliable inspection.

The apparatus shall be sufficiently robust to withstand the rough usage it is likely to receive in service and designed so that it will continue to function satisfactorily while temporarily, accidentally submerged in water at a maximum depth of one meter and thereafter, until the air in the cylinder is exhausted.

The apparatus is not designed for prolonged use under water. The apparatus shall be designed so that there are no parts or sharp edges likely to be caught on projections in narrow passages.

The apparatus shall be designed so that the wearer can remove it and, while still wearing the facepiece, continue to breath the air from the apparatus. The apparatus shall be designed to ensure its full function in any orientation.

The main valve(s) of the air cylinder(s) shall be arranged so that the wearer can operate them while wearing the apparatus.

9.2.2 Materials

All materials used in the construction shall have adequate mechanical strength, durability and resistance to deterioration, i.e. by heat or by contact with seawater. Such materials shall be anti-static as far as it is practicable.

Exposed part, excluding cylinders, i.e. those which may be subjected to impact during wearing shall not be made of magnesium, titanium, aluminum or alloys containing such proportions of these metals as will, on impact, give rise to frictional sparks capable of igniting flammable gas mixtures.

9.2.3 Cleaning and disinfection

The materials used shall withstand the cleaning and disinfecting agents recommended by the manufacturer. The process shall be approved by the testing authority.

9.2.4 Weight

The weight of the apparatus as ready for use with facepiece and fully charged cylinder shall not exceed 18 kg.

9.2.5 Connection (couplings)

The design and construction of the apparatus shall permit its components to be easily separated for cleaning, examining and testing.

The demountable connections shall be readily connected and secured, where possible by hand. Any means for sealing used shall be retained in position when the connection(s) is (are) disconnected during normal maintenance.

9.2.6 Facepiece connector

The connection between the facepiece and the apparatus may be achieved by a permanent or special type of connection or by a screw thread connection.

9.2.7 Body harness

The body harness shall be designed to allow the user to don and doff the apparatus quickly and easily without assistance and shall be adjustable. All adjusting devices shall be so constructed that once adjusted they will not slip inadvertently.

The harness shall be constructed such that when tested in practical performance tests the apparatus shall be worn without avoidable discomfort, the wearer shall show no undue sign of strain attributable to wearing the apparatus, and that the apparatus shall impede the wearer as little as possible when in a crouched position or when working in confined space.

9.2.8 Practical performance test

In addition to the machine tests described the apparatus shall also undergo practical performance tests under realistic conditions.

9.3 Performance

The apparatus shall operate trouble-free over the temperature range -30°C to +60°C. Apparatus specifically designed for temperatures beyond these limits shall be tested and marked accordingly.

9.4 Protection Against Particulate Matters

The component parts of the apparatus supplying compressed air shall be reliably protected against the penetration of particulate matter that may be contained in the compressed air.

9.5 High Pressure Parts

Metallic high pressure tubes, valves and couplings shall be capable of withstanding a test pressure of 50% above the maximum filling pressure. Non-Metallic parts shall be capable of withstanding a test pressure twice the maximum filling pressure of the cylinder.

9.6 Air Cylinders

The air cylinder shall comply with appropriate regulations. The cylinder shall be approved with respect to the appropriate filling pressure.

9.7 Cylinder Valves

The design of the cylinder valve shall be such as to ensure safe performance. The valve shall be so designed that the valve spindle cannot be completely unscrewed from the assembly during normal operation of the valve.

The valve shall be designed so that it cannot be closed inadvertently by contact with a surface by one of the following methods:

- a) The valve shall be designed so that a minimum of two turns of the handwheel are required to open fully the valve;
- b) the valve shall be lockable in open position.

Apparatus fitted with more than one cylinder may be fitted with individual valves on each cylinder.

9.8 Cylinder Valve Connection (Valve Outlet)

It shall not be possible to connect cylinders with a higher maximum filling pressure e.g. 300 bar (4350 psi) to an apparatus which is designed only for a lower maximum filling pressure e.g. 200 bar (2900 psi).

Note:

Only cylinders of equal maximum filling pressure shall be connected to an apparatus with more than one cylinder.

9.9 Pressure Reducer

Any adjustable medium pressure stage shall be reliably secured against accidental alteration and adequately sealed so that any unauthorized adjustment can be detected.

A pressure reducer safety valve shall be provided, if the apparatus cannot take the full cylinder pressure. If a pressure reducer safety valve is incorporated, it shall be designed to operate within the manufacturer's design parameters.

At maximum operating pressure of the pressure reducer safety valve the apparatus still has to permit breathing. The maximum pressure built up at the inlet of the lung governed demand valve shall be such that the wearer can continue breathing. Where demand valves open with medium pressure a pressure reducer safety valve need not be installed, provided the previous requirements are met.

9.10 Pressure Gage

The apparatus shall be equipped with a reliable pressure indicator which will read the pressure in the cylinder(s) on opening the valve or valves, to ensure that the individual or the equalized contents are measured respectively.

The pressure gage shall be placed to enable the pressure to be read conveniently by the wearer.

The pressure gage tube shall be sufficiently robust to withstand rough usage. Where the tube is protected by sheathing the enclosed space shall be vented to the atmosphere.

The pressure gage shall be resistant to dust and water and shall withstand immersion in water at a depth of one meter for 24 hours. After the test, no water shall be visible in the device.

The pressure gage shall be graduated from the zero mark up to value of at least 50 bar above the maximum filling pressure of the cylinder. The design of the gage shall allow the reading of the indicated pressure to within 10 bar.

When pressure gage and connection hose are removed from the apparatus, then the flow shall not exceed 25 LPM at maximum filling pressure of the cylinder.

9.11 Warning Device

The apparatus shall have a suitable warning device that operates when the cylinder pressure drops to a predetermined level to warn the wearer.

The warning device shall respond at the latest when only one-fifth of the total breathable air volume is left (tolerance +50 L) but at least 200 L are still available. After response of the warning device, the wearer shall be able to continue to breathe without difficulty.

If there is an audible warning device the sound pressure level shall be a minimum of 90 dB(A) as a continuous or intermittent warning at the wearer's ears. The frequency range shall be between 2000 Hz and 4000 Hz.

The air loss that might be caused by the warning signal shall not exceed an average of 5 LPM from response of signal to a pressure of 10 bar or not more than 50 L for those warning devices not operating continuously. The duration of the warning at 90 dB(A) shall be at least 15 s for a continuous signal and 60 s for an intermittent signal.

9.12 Flexible Hoses and Tubes

The hose may be extensible or compressible. The hose shall not collapse and the temporary elongation shall be at least 20%.

Tubes for the demand valve (connections included) shall withstand for at least 15 min. twice the operating pressure of the pressure reducer safety valve or at least 30 bar, whichever is the higher.

Any hose or tube connected to the facepiece shall permit free head movement and shall not restrict or close off the air supply under chin or arm pressure during practical performance tests.

9.13 Lung Governed Demand Valve

9.13.1 Breathable air supply

The breathable air supply shall be capable of a flow rate of at least 300 LPM at all cylinder pressures above 20 bar and of at least 150 LPM at a cylinder pressure of 10 bar.

9.13.2 Without positive pressure

The negative pressure for opening of the lung governed supply demand valve shall be between 0.5 m bar and 3.5 m bar when tested using a continuous flow of 10 LPM from maximum filling pressure down to 10 bar.

A self-opening of the demand valve at negative pressure of less than 0.5 m bar shall not occur.

At a flow rate of 300 LPM the negative pressure shall not exceed 10 m bar at all pressures down to 20 bar.

9.13.3 Supplementary air supply

Apparatus without positive pressure shall be provided with a manually operated means of providing a supply of air at a flow rate of at least 60 LPM at all cylinder pressures above 50 bar independently of the normal operation of the demand valve. Apparatus with positive pressure can be provided with such a device.

9.14 Adjustable Parts

All parts requiring manipulation by the wearer shall be readily accessible and easily distinguishable from one another by touch. All adjustable parts and controls shall be constructed so that their adjustment is not liable to accidental alteration during use.

9.15 Facepiece

Only a full face mask or a mouthpiece assembly shall be used.

9.16 Breathing Resistance

9.16.1 Inhalation resistance

9.16.1.1 Without positive pressure

The inhalation resistance of an apparatus without facepiece shall not exceed 4.5 m bar at all cylinder pressures from full to 10 bar.

Where a lung-governed demand valve is permanently attached to a full face mask the negative pressure shall not exceed 7 m bar.

9.16.1.2 With positive pressure

The apparatus shall be designed in such a way that at a flow rate of 300 LPM a positive pressure is maintained in the cavity of the mask adjacent to the face seal. This requirement shall be valid at all cylinder pressures above 20 bar.

9.16.2 Exhalation resistance

9.16.2.1 Without positive pressure

The exhalation resistance of an apparatus with facepiece shall not exceed 3.0 m bar.

9.16.2.2 With positive pressure

The exhalation valve shall have an opening resistance not exceeding 6 m bar, a resistance not exceeding 7 m bar at a continuous flow of 160 LPM a resistance not exceeding 10 m bar at a continuous flow of 300 LPM.

The static pressure in the mask cavity (inner mask, if applicable) under conditions of equilibrium shall not exceed 5 m bar.

9.17 Compatibility to Skin

Material that may come in direct contact with the wearer's skin shall not have any known harmful effects.

9.18 Tests and Certification

Open circuit breathing apparatus shall be tested and certified by testing authorities accepted by the Company. Tests certificate shall be supplied with the apparatus by the manufacturer. The tests shall cover the following in accordance with EN 137 clause 6. or equivalent e.g. NFPA Supplement 2 Code 1981 Chapter 1 to 4 (1991).

- a) Visual inspection;
- b) practical performance tests;
- c) resistance to temperature;
- d) pressure reducer test;
- e) warning device test;
- f) flexible hose test;
- g) lung governed demand valve;
- h) breathing resistance demand.

9.19 Instructions for Maintenance and Storage

- 1) On delivery, instructions shall accompany every apparatus enabling trained and qualified persons to use it.
- 2) The instructions shall comprise the technical data, the range of application and instructions necessary for correct fitting, care, maintenance and storage.
- 3) The instructions shall include that the air supply shall meet the requirements of breathable air.

Note:

To assure a reliable operation of the equipment, the following Table for moisture shall not be exceeded:

TABLE 1 - MAXIMUM MOISTURE CONTENT

FILLING PRESSURE bar	MOISTURE mg/m ³
200	50
300	35

- 4) Any other information the supplier may care to provide.
- 5) If the sub-assemblies are too small to be marked, those sub-assemblies shall be mentioned in the maintenance list.

9.20 Marking

9.20.1 All units of the same model shall be provided with a type of identifying marking. Sub-Assemblies and components with considerable bearing on safety shall be marked so that they can be identified. The manufacturer must be identified by name, trade mark or other means of identification.

9.20.2 Where the reliable performance of components may be affected by aging, the date (at least the year) of manufacture shall be marked.

9.20.3 The marking of the apparatus shall be provided with the following particulars:

- a) Serial number;
- b) year of manufacture.

9.20.4 Pressure reducer

The pressure reducer shall be durably marked with a serial number. The marking shall be such that the year of production can be ascertained. In addition, provision shall be made to mark the date (year and month) and test marks of the last testing performed.

9.20.5 The marking shall be as clearly visible and as durable as possible.

10. OPEN CIRCUIT ESCAPE SCBA

10.1 General

Open circuit SCBA is of a compressed air cylinder, a demand valve (or other device that adequately controls the air supply) and breathing tube to a facepiece, hood, mouthpiece or noseclip.

The exhale air passes to the atmosphere. The apparatus is intended for escape purposes only from irrespirable atmosphere.

10.2 Requirements

Materials, design and construction shall meet the specification of SCBA described in Clause 9 with the following exceptions:

- a) The time for which the apparatus will function when tested in accordance with Appendix A of BS 4667: Part 4 or equivalent using a breathing simulator set at a flow rate of 40 LPM and the rated duration shall not be less than 5 minutes.
- b) If an air line is used with this type of equipment, the apparatus shall be provided with a leak tight check valve and connector and if more than one apparatus is connected to the air line, the air flow available to each demand valve through the maximum length of air line supplied shall not be less than 40 LPM for each demand valve.

10.3 Instructions

The apparatus shall be supplied with dated instructions for storage, maintenance and use which shall include:

- a) The rated duration;
- b) guidance on donning and use;
- c) a warning that adequate protection may not be provided by the apparatus in some circumstance with certain highly toxic atmosphere;
- d) a warning that allowance should be made when the face seal fit of the facepiece will be adversely affected if the user wear spectacles or has sideburn or beard.

10.4 Marking

The apparatus shall be visibly marked with the following:

- a) The name trade mark or other means of identification of manufacturer;
- b) the number of official standard;
- c) the year of manufacture;
- d) the rated duration;
- e) the word (for escape purpose only).

10.5 Test and Certification

Manufacturer shall issue certification of testing authority certifying that all tests in accordance with Appendices A to G of BS 4667: Part 4 have been carried out and reporting that no malfunctioning of the apparatus has been occurred

11. VENTILATORY RESUSCITATORS

11.1 General

This section specifies performance and safety requirements of ventilatory resuscitator intended for use in patient of any body-mass. It covers both operator powered and gas powered resuscitator.

It also covers equipment essential for the use of resuscitator as a self contained piece of portable equipment e.g. oxygen supplying system and carrying case. Resuscitators for use with patient up to 40 kg bodymass shall deliver a tidal volume of 15 mL/kg and for use with the patient of over 40 kg body mass delivering a tidal volume of 600 mL and above shall be classified as adult resuscitators.

11.2 Dimension

The resuscitator including any carrying case or frame shall pass through a rectangular opening having dimension of 400 x 300 mm.

11.3 The Mass

The mass of resuscitator complete with its carrying case or frame and accessories including, (for gas powered resuscitators), the gas cylinder shall not exceed 16 kg.

11.4 Performance Requirement

11.4.1 Ventilation performance

11.4.1.1 Tidal volume

When tested, the resuscitator shall deliver the tidal volume range appropriate to its classification (patient up to 40 kg or over).

11.4.2 Pressure limitation

a) Operator powered resuscitator

If a pressure limiting system is provided in an operator powered resuscitator classified for use with patients with body mass exceeding 10 kg, pressure at the patient connection port shall not exceed 6 kPa.

b) Gas powered resuscitators

A pressure limiting system shall be provided in oxygen powered resuscitators as such that the pressure at the patient connection port shall not exceed 4.5 kPa. No mechanism to override the pressure limiting system shall be provided.

11.4.3 Supplementary oxygen and delivered oxygen concentration

11.4.3.1 Operator powered resuscitator

a) Operator powered resuscitator shall be provided with connection for supplementary oxygen that accepts elastomeric tubing having an inside diameter of 6 mm.

b) An operator powered resuscitator shall deliver an oxygen concentration of at least 40 Vol.%.

If fitted with an attachment to raise the delivered oxygen concentration, the resuscitator shall deliver an oxygen concentration, of at least 85 Vol.%.

11.4.3.2 Patient valve malfunctioning

Operator powered resuscitators having a facility to provide supplementary oxygen shall not fail to cycle from inspiration to expiration.

11.4.4 Resistance to spontaneous breathing

11.4.4.1 The pressure at the patient connection port shall not exceed 0-5 kPa for expiratory resistance and shall not fall by more than 0-5 kPa below atmospheric pressure for inspiratory resistance.

11.4.5 Oxygen supply for oxygen powered resuscitators

11.4.5.1 Oxygen cylinders, cylinder valve and connections

Oxygen cylinder connections shall be non-interchangeable between oxygen services.

11.4.5.2 A cylinder pressure gage or content indicator shall be provided for each cylinder connected to resuscitator.

11.4.5.3 If a detachable device is provided for opening the cylinder it shall be made captive by means of a retaining chain or similar attachment which shall withstand a static load of not less than 200 N without breakage.

11.4.5.4 Cylinder pressure regulator

Except when the resuscitator is designed to be controlled by adjusting the pressure regulator, the cylinder pressure regulator shall be pre-set and shall not be adjustable by the operator. The regulator shall be fitted with a relief valve that opens at a pressure not more than double its delivery pressure.

11.4.5.5 Filter

A sintered filter having pore size index no greater than 100 µm shall be provided in the supply to the pressure regulator.

11.4.5.6 Container capacity

The resuscitator carrying case or frame for oxygen powered resuscitator shall accommodate one or more oxygen cylinders which shall enable the resuscitator to supply at least 180 L of oxygen containing of 85% of oxygen or more.

11.4.5.7 Oxygen powered resuscitator shall deliver an oxygen concentration of at least 85 Vol.%.

11.5 Testing and Certification

Manufacturer of resuscitator shall supply certification of official testing authority with the equipment stating that all tests in accordance with BS 6850 or ISO 8382 Appendices A to K have been carried out before shipment.

11.6 Marking

11.6.1 Operating instructions

Basic operating instructions shall be provided either on the resuscitator or on the resuscitator carrying case or frame.

11.6.2 Marking on the resuscitator

The following informations shall be marked on the resuscitator:

- a) The classification (body mass range of adult);
- b) the number and date of official standard;
- c) the nominal pressure setting of the pressure limiting system;
- d) an identification reference to the batch or the data of manufacture;
- e) for oxygen powered resuscitators, the recommended range of gas supply pressure.

11.6.3 Cylinder connections

Each cylinder connection shall be clearly and permanently marked with the name of chemical symbol the gas that it accommodates.

11.7 Information to be Provided by the Manufacturer

11.7.1 General

The manufacturer shall provide manual of operating and maintenance instructions. The size and shape shall be such that it can be enclosed within or attached to the carrying case or frame. The manual shall include the following:

- a) A warning that the resuscitator shall only be used by persons who have received training.
- b) Instructions on how to make resuscitator operational in all intended modes of operation.
- c) A specification dealing the following:
 - 1) The body mass range for which the resuscitator is suitable for use.
 - 2) Range of frequency.
 - 3) Attainable delivery pressure.
 - 4) Operating environmental limit.
 - 5) Storage environmental limit.
 - 6) For operator powered resuscitator, the delivered oxygen concentrations at stated supplementary flows.
 - 7) The total volume range.
 - 8) The expiratory and inspiratory resistance excluding details of any such resistance imposed by special fittings that are supplied by the resuscitator.
 - 9) End expiratory pressure in normal use if greater than 0.2 kPa.
 - 10) For patient demand valves, the pressure of termination of flow if above atmospheric
 - 11) Detail of pressure limiting system and the mechanism to override it, if any
- d) Instructions for dismantling and reassembly of components, if applicable, including an illustration of the component parts in their correct relationship.
- e) Recommended methods of cleaning and disinfection or sterilization of the component parts in their correct relationship.
- f) A test of resuscitator function that may be performed by the operator at the point of use.
- g) A list of parts that may be replaced by the operator.
- h) Recommendations for use of resuscitator in hazardous or explosive atmosphere, including a warning that, if it will entrain or permit the patient to inhale gases from atmosphere. Contaminated environment may be hazardous unless entrainment is prevented. The manufacturer shall describe how to prevent entrainment or inhalation.

- i) Warning that in the presence of high oxygen concentration there is a danger from operator smoking or from open flames and that oil shall not be used with the resuscitator.
- j) The fault finding and correction procedures.

11.7.2 Oxygen powered resuscitator

In addition to the above informations, the manual for oxygen powered resuscitator shall include the following informations:

- a) The approximate duration of a single oxygen cylinder 457 mm long and 102 mm outside diameter containing 340 L of oxygen when the resuscitator is delivering a minute volume of 10 L and concentration of at least 85% oxygen or the manufacturer's selected concentration less than 85% oxygen.
- b) If the resuscitator will deliver concentration of oxygen less than 85 Vol.% the concentration delivered at the maximum and minimum tidal volume settings:
- c) The flow from the patient connection port against leak pressure of 1.5 kPa and 3 kPa.
- d) The recommended range of oxygen supply pressure and flows.
- e) The duration of oxygen cylinder supplied with the resuscitator under stated conditions.

PART II
SELECTION, USE, INSPECTION
AND
MAINTENANCE

12. SELECTION OF RESPIRATORY PROTECTIVE EQUIPMENT (see Fig. 5)

12.1 General

The multiplicity of hazards that may exist in a given operation requires careful evaluation followed by intelligent selection of protective equipment. This selection is made even more complex by the many types of equipment available, each having its limitations, areas of application and operational and maintenance requirements.

The selection of correct respiratory protection equipment for any given situation requires consideration of the nature of the hazard, the severity of the hazard, work requirements and conditions, and the characteristics and limitations of available equipment. Where there is any doubt about the suitability of a respirator, breathing apparatus should be used. Particular care is necessary in the case of odorless gases or fumes as these do not give a warning of their presence.

Some respirators and breathing apparatus deliver air to the user at pressures slightly above ambient pressure. These can provide greater protection since any gas flow through leaks in the system will be outwards. For this to be so, however, the pressure bias needs to be sufficient to ensure that the pressure within the mouth and nose remain positive throughout the respiratory cycle. In the case of breathing apparatus, should the leak rate be excessive, the duration will be reduced. Since the reductions in pressure on inhalation depend upon respiratory resistance, the performance of positive pressure devices should always be checked with all resistances to respiration attached.

12.2 Severity and Location of the Hazard

12.2.1 Only protective devices that arrange for the provision of an independent atmosphere suitable for respiration are appropriate for use in oxygen deficient atmospheres and self-contained, air line, or fresh air hose apparatus should be used.

12.2.2 The concentration of the contaminant and its physical location should be considered and account should also be taken of the length of time for which protection will be needed, entry and exit times, accessibility of a supply of air suitable for respiration, and the ability to use air lines or move about freely while wearing the protective device.

12.2.3 Where flammable or explosive atmospheres may arise, the equipment should be suitable for use in such circumstances.

12.3 Work Requirements and Conditions

12.3.1 Working duration

The duration of work usually determines the length of time for which respiratory protection is needed and includes the time taken to enter and leave the contaminated area. With self-contained breathing apparatus and canister or cartridge respirators, the protection time is limited whereas compressed air line and fresh air hose apparatus provide protection for as long as the facepiece is supplied with adequate air suitable for respiration. Dust respirators normally provide protection until the filter loading becomes excessive.

Some canister respirators have a means for indicating the remaining services life visible through a

window in the canister. Canisters and cartridges should be changed according to the manufacturer's instructions. Warning devices are sometimes fitted to self-contained breathing apparatus. The user should understand the operation and limitations of each type of warning device.

12.3.2 Activity of wearer

The work area to be covered, work rate and mobility required of the wearer in carrying out his work should be considered in the selection of respiratory protective equipment.

Canister, cartridge and dust respirators present minimum interference with wearers movements, but high resistance to breathing within respirators in conditions of heavy work can result in distressed breathing. Compressed air line and fresh air hose apparatus severely restrict the area their wearers can cover and present a potential hazard where trailing lines and hoses can come into contact with machinery. Self-Contained breathing apparatus present a size and weight penalty which may restrict movement in confined spaces and when climbing. The wearer's work rate determines his respiratory minute volume, maximum inspiratory flow rate and inhalation and exhalation breathing resistance. The respiratory minute volume is of great significance in self-contained and compressed air line apparatus operated from cylinders as it determines their working duration which may, in moderate work conditions, be only one-third of that in a condition of rest.

12.3.3 Vision

All facepiece will restrict vision to some degree and the restriction should be taken into account when training wearers. Other problems include the wearing of prescription spectacles and mustache.

12.3.4 Communication

Effective speech communication may be required for certain work.

12.3.5 Temperature extremes

The ability to withstand stress caused by temperature extremes is especially important in emergency situations when only immediately available protective devices can be used (see Clause 13.4).

12.3.6 Eye protection

Eye protection may be necessary when half-masks and mouthpieces and noseclips are worn. In such cases, the eye protectors should be compatible with the respiratory protective equipment.

12.3.7 Wearer acceptability and facepiece fit

The factors are of prime importance in the selection of equipment. The wearer's acceptance of a particular device depends upon the degree of facepiece discomfort, interference with vision, its weight, breathing resistance and individual physical condition and psychological factors. The fit depends upon facepiece design, facial features and hair, and is usually the most important factor in obtaining proper protection with a respirator, particularly of the half-mask type.

13. USE OF RESPIRATORY PROTECTIVE EQUIPMENT

13.1 General

13.1.1 Operating procedures

Standard procedures should be developed which should take account of all the information and guidance given in these recommendations and in the manufacturer's instructions. All possible emergency and routine uses of respiratory protective equipment should be anticipated and procedures laid down. Written procedures should be prepared concerning the safe use of respiratory protective devices in dangerous atmospheres that might be encountered in normal operations or emergencies. Users should be familiar with these procedures and with available device.

13.1.2 Issue of equipment

The appropriate equipment should be specified for each job and should be specified in the work procedures by a qualified person supervising the respiratory protection program. The person responsible for issuing equipment should be adequately instructed to ensure that appropriate types are issued. Each device that is permanently allocated to an individual should be durably marked with his name; the marking should not be such as to affect performance. Dates of issue should be recorded.

13.1.3 Work in confined spaces and toxic or oxygen deficient atmospheres, e.g. tanks and vessels

When the equipment is worn in an atmosphere from which the wearer would be unable to escape without its protection, he should, where practicable, use a lifeline and be attended by another person. Where possible, he should be under the surveillance of a person in uncontaminated air to whom suitable respiratory equipment is immediately available, and who is instructed in the methods of resuscitation including the administration of oxygen and means for summoning assistance in an emergency.

13.1.4 Training in proper use

For safe use of any respiratory protective device, it is essential that the user be thoroughly instructed in its use and maintenance. Both supervisors and workers should be instructed by a competent person. Minimum training should include:

- 1) Instruction in the nature of the hazard and a close appraisal of what may happen if the device is not used;
- 2) instructions as to why the particular device is appropriate to the hazard;
- 3) an explanation of the device's capabilities and limitations;
- 4) instruction and training in the actual use of the device and close supervision to ensure that it continues to be properly used;
- 5) disinfection (see Clause 14.2).

Users should be given regular practice in handling the equipment, fitting it properly, testing facepiece fit and becoming familiar with it.

13.2 Test for Fit of Facepiece

The fit of the facepiece is most important and wearers should receive instructions including demonstrations and practice in how it should be fitted, and how to determine if it is fitting correctly. A satisfactory fit of a full facepiece cannot be expected when spectacles are worn unless spectacles

are specially made for this purpose; beards and whiskers are also likely to affect fit adversely.

To ensure proper protection, the facepiece fit should be checked by the wearer each time he puts it on. This may be done as follows:

Negative pressure test

Close the inlet of the equipment. Inhale gently so that the facepiece collapses slightly, and hold the breath for 10 seconds. If the facepiece remains in its slightly collapsed condition and no inward leakage of air is detected, the tightness of the facepiece is probably satisfactory. If the wearer detects leakage, he should re-adjust the facepiece, and repeat the test. If leakage is still noted, it can be concluded that this particular facepiece will not protect the wearer. The wearer should not continue to tighten the headband straps until they are uncomfortably tight, simply to achieve a gas-tight face fit.

Note:

It may not be possible to carry out this test with certain types of apparatus in which event the manufacturers should be consulted.

13.3 Use in Low Temperatures

Major problem in the use of full facepieces at low temperatures are poor visibility and freezing of exhalation valves. All full facepieces should be designed so that the incoming fresh air sweeps over the inside of the eyepieces to reduce misting. Anti-mist compounds may be used to coat the inside of eyepieces to reduce misting at room temperatures and down to temperatures approaching 0°C.

Full facepieces are available with inner masks that direct moist exhaled air through the exhalation valves, and when properly fitted are likely to provide adequate visibility at low temperatures.

At very low temperatures the exhalation valve may collect moisture and freeze open allowing the wearer to breathe contaminated air, or freeze closed, preventing normal exhalation. Dry air suitable for respiration should be used with self-contained and compressed air line breathing apparatus at low temperatures. The dew-point of the breathed gas should be appropriate to the ambient temperature.

High pressure connections on self-contained breathing apparatus may leak because of metal contraction at low temperatures but the only penalty is likely to be an outward leakage.

13.4 Use in High Temperatures

A man working in areas of high ambient or radiant temperatures is under stress and any additional stress caused by the use of respiratory protective devices should be minimized. This can be done by using devices having a low weight and low breathing resistance. Supplied air respirators and hoods and blouses, having an adequate supply of cool breathing air are recommended.

13.5 Use of Dust Canister and Cartridge Respirators

13.5.1 Before entering a contaminated atmosphere, steps should be taken to ensure that it is not deficient in oxygen and that the contaminant level is appropriate to the protection.

13.5.2 The filters of dust respirators will, after a period of time, gradually become choked by trapped particles during use and breathing may become progressively more difficult. They should be replaced outside the contaminated atmosphere.

13.5.3 When using canister or cartridge respirators, it is essential to select the correct canister or cartridge for the given hazard. The instructions with the canister should always be read before use and if possible the wearer should ascertain the useful remaining life of the canister and ensure that he does not remain in the contaminated atmosphere for longer than that time. If the remaining life is not known, the canister should be replaced.

13.5.4 Some types of canister have a seal over the air entrance which must be removed to permit breathing. It has to be remembered that after the seal is broken the contents can deteriorate and become ineffective.

13.5.5 The replacement of canisters should be the responsibility of a competent person with knowledge of their life and of the use to which they are being put.

13.5.6 Cartridges have a very limited life and should be replaced regularly according to the circumstances of their use. If the mask leaks or the canister is exhausted, the user will usually know by odor, taste, or irritation of eye, nose, or throat, and should immediately return to fresh air.

If the canister is used up, it should not be left attached, but removed, and a new one should be selected and fastened in place. When a respirator is worn in a gas or vapor that has little or no warning properties, like carbon monoxide, it is recommended that a fresh canister be used each time a man enters the toxic atmosphere.

Note:

Cartridge and canister type respirators shall not be used in confined spaces.

13.6 Use of Air Line Breathing Apparatus

13.6.1 Air lines and air hoses

Before being put into use, air lines and air hoses should be examined externally for defects and tested for freedom from blockage. The intake end of fresh air hoses should be positively fixed in a position from which clean fresh air can be drawn. Precautions against interference with them and against contamination of the air supply by vehicles and mobile equipment may also be necessary. Precautions should be taken to prevent the air line or hose fouling on projections or being damaged.

13.6.2 Compressed air supply

There are three methods of providing air for breathing purposes:

1) Separate breathing air service

The provision of an air service separate from the normal works air service is the best method of supplying air for personal protection and should always be considered for installation in new works or where major alterations justify it.

2) General works air service

The breathing air service may be taken from the general works air supply but only after special precautions against any contamination have been taken.

3) Portable air supplying units

Where breathing air is required infrequently, or in an emergency, or in remote places, a portable air supply unit should be used.

13.6.3 Requirements for all compressed air systems for air line breathing apparatus

13.6.3.1 Air purity

Air being supplied to the wearer should not contain impurities in excess of the following limits:

Carbon monoxide	5 parts per million (5.5 mg/m ³)
Carbon dioxide	500 parts per million (900 mg/m ³)
Oil mist	0.5 mg/m ³

Odor and Cleanliness

The air must be free from all odor and contamination by dust, dirt or metallic particles and should not contain any other toxic or irritating ingredients (see Note).

Note:

Odor and cleanliness of compressed air is difficult to check accurately without special equipment. A rough check may be made by smelling the delivered air and by noting any discoloration or wetness when the air is passed gently through a wad of tissue or filter paper. An absorption filter may be necessary to remove odor. There should be no free water in the air supply.

13.6.3.2 Compressors

Compressors, particularly the exhaust valves, should be well maintained and should not be allowed to overheat as a dangerous amount of carbon monoxide or other toxic substances may be produced by the decomposition of lubricating oils.

13.6.3.3 Air supply

The capacity of any air service for personal protection should be calculated on a minimum requirement of each person of 120 LPM. The pressure of air admitted to the kink-resistant tubing connected to personal protective apparatus should be within the safe working pressure for the tubing and should never be at a pressure less than 345 m bar, (5 psi).

13.6.3.4 Air temperature and humidity

Air supplied to the mask, hood or other device should normally be at a comfortable breathing temperature within the range of 15 to 25°C. The wearer's comfort is influenced by the humidity of the air breathed and it is recommended that 85% relative humidity should not be exceeded.

13.6.3.5 Air intake

The air intake provided for any breathing air service should be sited and constructed so as to avoid the entry of contaminated air into the system and ensure a sufficient supply of air suitable for respiration. The use of filters on any intake should be of secondary importance to the foregoing requirements.

13.6.3.6 Recharging of air cylinders

When an air compressor is used to charge air cylinders, the manufacturer's instructions should be carefully followed. These will usually provide for the compressor to be run for a few minutes with drain valves open before cylinder charging commences and for opening the drain valve on completion of charging. After use, compressors should not be left under pressure for long periods.

13.6.3.7 Air supply in an emergency

Every system of air supply employed should incorporate a receiver of sufficient capacity to enable persons to escape from an irrespirable atmosphere in the event of a failure of the prime mover

supplying the air.

13.6.3.8 Warning device

Arrangement should be made to warn the user whenever the air pressure falls to the minimum safe working level.

13.7 Use of Self-Contained Breathing Apparatus

13.7.1 Air and oxygen supplied from cylinders should be in accordance with 7.6.3.1 and should preferably have a dewpoint not exceeding -50°C at atmospheric pressure.

13.7.2 With every type of self-contained breathing apparatus it is essential that the manufacturer's instructions are followed and that the apparatus is donned in air suitable for respiration.

13.7.3 The apparatus should be checked immediately before entry into a contaminated atmosphere.

13.7.4 Once a cylinder has been used, for however a short period, the cylinder should be recharged as soon as possible. The valves of empty cylinders should be kept closed until the cylinders are recharged.

13.7.5 Bearing in mind the limited duration of the apparatus, care should be taken to allow sufficient time to reach air suitable for respiration.

13.7.6 The mouthpiece and noseclip, or the facepiece, should not be removed until the wearer is certain that he can do so without danger.

14. CARE AND MAINTENANCE OF RESPIRATORY PROTECTIVE EQUIPMENT

14.1 General

The program for the care and maintenance of equipment should be appropriate to the type of plant, working conditions and hazards involved and should ensure that the equipment is properly maintained to retain the original performance standards. Arrangements should include those for:

- 1) Inspection for defects;
- 2) cleaning and decontaminating;
- 3) repair;
- 4) storage;
- 5) issue.

Where many respiratory protective devices are in use, a central station for care and maintenance under a suitably instructed supervisor is desirable.

14.2 Cleaning and Decontamination

Equipment that is used regularly should be collected, cleaned and decontaminated as frequently as necessary to ensure that proper protection is provided for the wearer. It should be cleaned as soon as possible after each use as moisture allowed to dry on the valves will interfere with their correct functioning.

The facepiece and breathing tube should be removed from the rest of the apparatus and cleaned by washing with soap and warm water and then thoroughly rinsed. In addition, wiping out the facepiece with a dilute solution of rinsing disinfectant may make the equipment more acceptable to the user. The equipment should then be dried out by direct sunlight. Proper cleaning and decontamination requires care and the manufacturer's instructions should be followed; in particular, temperatures above 85°C should never be used for decontamination. Many cleaning agents commonly used are

irritating to the skin and if not completely removed from the facepiece by thorough rinsing, may cause skin rashes.

Each employee should be briefed on the cleaning procedures and have confidence that he will always be issued with clean and uncontaminated equipment.

Respiratory protective devices may be contaminated by toxic materials such as organic phosphates, pesticides and radionucleic. If the contamination is light, normal cleaning should provide satisfactory decontamination; if heavy, a separate decontamination process may be required before cleaning.

14.3 Servicing

Servicing should be carried out only by experience persons using parts designed for the particular respiratory protective devices. No attempt should be made to replace components or to make adjustments or repairs beyond the manufacturer's recommendations. Valves and regulators should be passed to a competent person for adjustment or repair.

Dust respirator filters should be renewed as soon as increased breathing resistance becomes evident. Gas respirator canisters and cartridges should be renewed not later than the expiry of the maximum service life (assuming exposure to maximum concentration), as stated by the manufacturer.

Immediately after use, used and partly used cylinders or other containers of compressed air or oxygen on self-contained breathing apparatus should be replaced by fully charged cylinders and the absorbents of closed-circuit apparatus renewed.

It is dangerous to use organic-based oils and greases for lubricating cylinder valves, gages, reducing valves or other such fittings on oxygen equipment.

14.4 Storage

After inspection, cleaning and any necessary repair, respiratory protective equipment should be stored in suitable holder boxes to protect against dirt, oil, sunlight, extreme heat and cold, excessive moisture and harmful chemicals. They should be stored so that the equipment is not subjected to distortion.

Respirators placed ready for emergency use should be stored in special clearly marked cabinets and may also be enclosed in plastic bags to protect them from corrosive atmospheres.

To prevent tampering with canisters it may be desirable to store them in sealed containers bearing the date of the last use. Care should be taken to replace stored canisters before their shelf life is exceeded. The ends of air lines should be sealed to keep the lines internally clean.

14.5 Records

Each respiratory protective device should be given a distinguishing number, and a record of cleaning, inspection and maintenance should be kept. A record should also be kept of each canister and cartridge showing when it was opened and the duration and conditions of use.

15. SPECIAL PROBLEMS

15.1 Beards

It is unlikely that a facepiece fit to the specified standards will be obtained by men with beards or with side-whiskers that interfere with the face seal.

15.2 Corrective Spectacles and Protective Eyewear

A satisfactory fit of a full facepiece cannot be expected when spectacles are worn unless the spectacles are specially made or adapted. As an expedient, spectacles without side arms or with short side arms may be taped to the wearer's head. If it is necessary to wear eye protection with half-masks, care should be taken in selection that no mutual interference results.

15.3 Communication

Normal facepieces distort the voice to some extent but the exhalation valve usually provides some speech transmission over short distances in relatively quiet conditions. However, speech can cause facepiece or component leakage and should be limited especially when wearing a half-mask.

Mechanical speech transmission devices are available as an integral part of some respirators. These consist of a resonant cavity and diaphragm which amplifies the sound in the frequency range most important to speech intelligibility. The diaphragm acts as a barrier to the ambient atmosphere and should be carefully handled and protected by a cover to prevent puncture.

Various methods of transmitting speech electronically from the facepiece are available and usually make use of a microphone connected to a telephone or radio transmitter. Usually the microphone is mounted in the facepiece, with the amplifier, power pack and loudspeaker or transmitter attached to the outside of the facepiece, carried on the body or remotely located. Facepieces with electric or electronic speech transmission devices having an integral power supply or one attached to the body should be certified as intrinsically safe or flameproof if they are to be used in flammable or explosive atmosphere.

Means for speech transmission may be incorporated in full facepieces for use with self-contained and air line breathing apparatus.

16. INSPECTION, CARE AND MAINTENANCE OF RESPIRATORY EQUIPMENT

16.1 General

Strict attention to the care and maintenance of all types of respiratory equipment used is of vital importance for the safety of user. More damage is probably caused by incorrect maintenance and during storage than incurred during actual work operations.

It is essential that respiratory equipment be thoroughly examined for damage and defect before and after every occasion on which it is used and all defects to be rectified before the equipment is used again.

Equipment to be checked are:

- a) Air purifying respirators;
- b) atmosphere air, supplied respirators;
- c) air line respirator;
- d) self contained breathing apparatus.

The recommendations made in the following clauses concerning the handling of the various components shall be most carefully observed and the manufacturers instructions with regard to the assembly, adjustment, replacement of components and maintenance shall be obtained and followed.

16.2 Respiratory Equipment

16.2.1 Supervisors shall be responsible for making daily inspection, particularly of functional parts such as exhalation valves and filter elements. They should see that the edges of the valves are not curled and that valve seats are smooth and clean. Diaphragm of inhalation and exhalation valves

should be replaced whenever is deteriorated.

16.2.2 In addition to the daily check, respirators shall be inspected weekly by trained person. During the weekly inspection, rubber parts should be stretched slightly for detection of fine cracks. The rubber should be worked occasionally to prevent settings. One of the causes of cracking, and the stretch of headband to be checked is that the wearer has not stretched it in an attempt to secure a snug fit.

16.2.3 In an effort to reduce resistance to breathing, employees will punch holes in the filter, the rubber facepiece, or other parts, which is a dangerous practice and must be ceased.

16.2.4 In cleaning respirators, dirt and dust should first be blown from them by means of compressed air at not more than 1.5 bar pressure through a fixed nozzle directed towards an exhaust hood. Dust filters shall not be cleaned by brushing.

16.2.5 Filters, screens, headbands, and cotton facelets shall be removed, if respirators are coated with paint or other foreign matter. They should be soaked for 3 hours in a cleaning solution of 1 kilogram of commercial alkaline base cleaner and 30 L of water. Fresh paint can be wiped off with a clean rag moistened in alcohol.

Respirators having no visible accumulation of foreign matter shall be scrubbed in warm soapy water, rinsed, disinfected, then rinsed again and dried.

16.2.6 Dirty or oily elastic head bands should be washed in warm soapy water and rinsed. Cleaning of filter depends in their design. Respirators that have replaceable filters can be cleaned and reused. The cleaning methods vary with the filter composition and design. Only cleaning methods that are recommended by the manufacturer should be used.

16.2.7 Employees should be instructed to wipe off oil, grease and other harmful substances from headbands and other parts of the respirators as soon as they collect. They should be instructed not to use solvents to clean plastic or rubber parts.

16.2.7.1 Most face and mouth pieces of respiratory protective devices are made of rubber or rubber like compounds. Usually hand brushing or agitation in soapy water is sufficient to clean them. Aqueous solution or any other disinfectant in solution in warm water can be used to disinfect the parts. The parts shall then be rinsed in clean water and dried quickly. Hot water, steam, solvents and ultraviolet shall not be used to clean and disinfect rubber parts because they have a deteriorating effect.

16.2.7.2 Before being stored, a respirator should be carefully wiped with a damp cloth and dried. It should be stored without sharp folds or greases. It should never be hung by the elastic head band or put down in a position which will stretch the facepiece.

16.2.8 Since heat, air, light, and oil cause rubber to deteriorate, respirators shall be stored in a cool, dry place and protected from light and air as much as possible. Wood, filter or metal cases are provided with many respirators. Respirators shall be sealed in clean plastic bags.

16.3 Canister and Cartridges

16.3.1 General

Although a year is usually given as the maximum effect life of a canister, it is possible for an unused canister to deteriorate in less than a year to the point where it becomes unusable. Canister shall be replaced, therefore not more than one year after the date, when the seal is initially removed. Canisters stored with seals intact shall be replaced on or before the recommended use and the date stamped on each canister.

16.3.2 Storage

Safe storage life for nonwindow indicator universal masks canisters stored in a dry place is 5 years, even sealed canisters take up some moisture during storage.

Tests show that a sealed canister loses much of its effectiveness against carbon monoxide after it

has gained 45 grams in weight. It is recommended, therefore, that sealed canisters (except the window indicators types) be weighed as soon as received from the manufacturers and the weight should be marked indelibly on each canisters. Stored canisters should be reweighed from time to time, when the weight increases 45 grams, the canister even though the seal remain unbroken shall be discarded.

A card should be set up for each mask to indicate the date of latest inspection and replacement of the canister and the amount of use which the canisters has had. It is wise to replace canister after each emergency use.

16.3.3 Cartridge respirator

Cartridge respirators are for use only in non emergency situation that is, for atmosphere which are harmful only after prolong exposures. Filters shall be replaced whenever breathing becomes difficult due to plugging of filters by retained particulates.

16.4 Atmosphere Air Supplied Respirator

16.4.1 Airline respirators

Air line and breather tube should be blown out with air before a mask is put on to eliminate dust and fumes that may have accumulated within the mask. The couplings in the hose line should be tested for tightness.

The body harness needed to pull the hose lines require inspection prior to each use. The component parts of the harness shall withstand a pull of at least 120 kg. Parts which have to be used shall be examined and checked for signs of wear and deterioration.

16.4.2 The airline respirator of continuous flow or demand flow types limitations shall be understood. A trap and filter must be installed in the compressor line ahead of the mask to separate oil, water, scale or other extraneous matter from the air stream. A pressure regulator with an attached gage is required if the pressure in the compressor line exceeds 1½ bar.

There should be a pressure relief valve set at the predetermined range, which will operate if the regulator failed. The air supply must be free of carbon monoxide or other gaseous contaminations. For safety of user the components of all types of hose line respirators shall be inspected before each use.

Low pressure blower which do not use internal lubricants are preferred. Components of air line respirators using compressed supply air cylinders shall also be checked and inspected frequently and before each use. Air must be free of contaminants.

16.5 Self-Contained Breathing Apparatus

16.5.1 General

Self-contained breathing apparatus require rigid inspection and maintenance because it is usually used under the most adverse circumstances. Periodic inspections shall be made and record kept. All connector valves and hoses should be inspected to assure proper function when needed, and manufacturers instructions shall be followed.

A preventive maintenance program for breathing apparatus is the only assurance that the device will operate properly when need arises. Bearing in mind that more damages is probably caused by incorrect maintenance and during storage than is incurred during actual work operations.

Materials covered are cylinders, valves, demand regulators, pressure reducing valves, manifolds, pressure gages, flexible hoses and rubber fabric or plastic components.

The recommendations made in the following clauses concerning the care and maintenance of the various components shall be most carefully observed and the makers instructions with regard to assembly, adjustment, replacement of components and maintenance shall be obtained and

followed. Mistreatment, careless manipulation with improper tools also may not give rise to dangerous defects, but renders further maintenance expenses.

16.5.2 Cylinders

16.5.2.1 Handling

Cylinders should be handled with care and should not be dropped or roughly treated; when being transported they should be firmly secured so that they cannot move about.

16.5.2.2 Storage

The condition of the inside of the cylinder can be maintained by keeping it dry at all times. The cylinder should be filled with dry air, and never completely discharged. Cylinders should be stored, preferably in the vertical position, in a cool, dry place adequately protected from the weather and away from excessive heat and direct exposure to the sun.

Once a cylinder has been put into service, it should never be left completely discharged. A slight positive pressure should always register on the gage.

16.5.2.3 Maintenance

Protection against corrosion is important. The paintwork, metal spray undercoating (where applied) and fittings should be kept in good condition. Scratching of cylinders should be avoided. Protection by electro-plating methods is not recommended. Heat or chemical strippers should not be used to remove old paint from any type of cylinder, cylinders should not be modified under any circumstances. This may result in serious weakening of the cylinder and lead to accident.

The threads in the cylinder neck should not be altered in any way. Bushes or adapters should not be used. If the cylinder is not required for a long period, e.g. 6 months, it is recommended that it be made ready by responsible employee for discharging, removal of the valve, extraction of any oil or water, drying out and refitting of the valve. The cylinder should then be recharged to a slight positive pressure. If the cylinder is not to be recharged immediately, it should be left with the valve closed.

A cylinder that has failed on inspection should be left with a responsible person who will then destroy it.

16.5.2.4 Recharging

Recharging should be undertaken only with proper equipment that ensures the compressed air is free from moisture, oil and other impurities, and is fit for breathing purposes.

Never put oxygen or any gas, other than air, in an air cylinder.

Before recharging a cylinder, it is the responsibility of the supervisor to ensure that the cylinders are retested hydraulically unless this has been carried out within the prescribed retesting period.

Cylinders shall be visually examined and hydraulically tested. A certificate should be obtained after each test.

It is essential that cylinders be charged carefully and slowly to prevent overcharging, and that the charging pressure be such that, after cooling to ambient temperature, the rated pressure for the cylinder is not exceeded.

Before recharging, the valve should be cracked open to blow clear any dust or moisture in the valve passages. The rated working pressure at 15°C, in bars, should be stamped on the cylinder.

It should be noted that, if a cylinder is subjected to heat from any source, the pressure inside it will increase.

Overcharging of cylinders is highly dangerous.

16.5.2.5 Identification of cylinders

It is essential that each storage cylinder be painted with identification colors for "Air", i.e. grey body with black and white quarters at the valve end; and the words "Breathing Air" clearly stenciled or painted on the cylinder in a contrasting color.

16.5.2.6 Cylinder valves

Lubricants

Cylinder valves should be lubricated only with lubricants recommended by the manufacturer of the apparatus. Other lubricants should not be applied to any of the valve parts or to the connecting fittings, as this may result in an explosion, or may contaminate the air, making it unsafe for breathing.

16.5.2.7 Faulty valves

General

A cylinder with a damaged valve should never be used. If a valve is leaking, this fault should be corrected. Valve leaks may be broken down into two categories, both of which may be identified by an underwater bubble test.

16.5.2.8 Valve seat leaks

If the valve of a fully charged cylinder held underwater is seen to emit gas bubbles, this is an indication of seat leakage. If tightening the handwheel fails to stop the bubble flow, the cylinder should be discharged and sent to a responsible person for the valve to be repaired.

16.5.2.9 Gland leaks

If the test described in 16.5.2.8 shows the valve seat is gas tight, the outlet should be carefully dried and then blanked off by attaching the regulator that would normally be fitted to it, or with a suitable high pressure plug. The valve should again be immersed in water and the handwheel should be opened. Bubbles forming at the point where the valve spindle enters the main valve are indicative of a gland leak, in which case the cylinder should be discharged and sent to a responsible person for repair.

16.5.2.10 Repair

No attempt should be made to remove a valve. Where bent, broken or damaged valve spindles are found or the valve is excessively stiff in operation, the valved cylinders should be returned to a competent person for the valve to be serviced or replaced.

16.5.2.11 Care after use

Immediately after use, the valve should be closed finger tight. It is recommended practice to close the valve while there is still a slight positive pressure in the cylinder.

16.5.2.12 Maintenance

Maintenance and fitting of cylinder valves should be carried out only by authorized person. In the interests of safety, it is essential that the valves be inserted into the cylinder necks with the correct torque.

After a valve has been fitted, the cylinder should be air tested to its full working pressure so that leaks and correct valve functioning can be checked.

16.6 Demand Regulators, Pressure Reducing Valves and Manifolds

16.6.1 Examination before use

The following procedures should be carried out before use:

- a) Read the manufacturer's handbook.
- b) Check the seal for defects before fitting the demand regulator or reducing valve to the cylinder or manifold and renew if it is damaged or badly worn.
- c) Check that the filter, if fitted, is clean and in good condition. If found to be in poor condition, it should be replaced.
- d) Check the mechanical air reserve valve, if fitted, for freedom of operation and ensure that it is returned to the "Normal" or "Main Supply".
- e) Before fitting the demand regulator to the cylinder, position the cylinder so that the valve is at the bottom end, and crack the valve to blow out any dirt.
- f) Carry out a high pressure test as follows:
 - 1) Open the cylinder valve and check that there are no audible leaks.
 - 2) Check the cylinder pressure. It is recommended that the cylinder be fully charged. At no time should any emergency work in confined spaces be carried out without an adequate air supply. The cylinder pressure should again be checked immediately. Caution should be exercised when opening the valve.
 - 3) Close the cylinder valve and check that the pressure in the high pressure system does not fall more than 10 bar in 1 min.
 - 4) Locate any leaks by submerging the set in water.
- g) Carry out a low pressure test as follows. Breathe from the apparatus for 1 min to 3 min and check by taking several deep sharp breaths that there is no restriction to breathing. Close the cylinder valve and continue breathing until all air in the tube is exhausted. If it is then possible to draw in any air, there is a low pressure leak that should be found and rectified.

16.6.2 Cleaning

Cleaning should be carried out in accordance with the manufacturer's instructions. Where the apparatus has been used under very dirty or oily conditions, it may be advisable to remove the regulator diaphragm to facilitate cleaning. Warm, soapy water should be used to remove any oil. Do not use solvents or detergents.

Particular attention should be paid to the sealing surfaces of any associated non-return valves to make sure that they are quite clean, dry and free from deposits.

16.6.3 Maintenance

Non-metallic components such as non-return valves, regulator valves, diaphragms, etc., are liable to deterioration, and this can interfere with the operation of the apparatus. The greatest care should be taken to observe the manufacturer's instructions.

Demand regulators should be serviced regularly by an authorized person at intervals of not more than one year.

16.7 Pressure Gages

16.7.1 Examination before use

The following procedures should be carried out before use:

- a) Check for signs of visible damage, e.g. broken glass, bent gage needle, reading off zero, dents in casing ingress of water, etc.
- b) Connect the gage to the breathing regulator and source of high pressure air. Open the cylinder valve slowly and check that the gage needle moves smoothly and indicates the cylinder pressure; this should remain steady.
- c) Close cylinder and watch the pressure gage needle. If the indicated pressure drops and the high pressure side of the apparatus has been tested as outlined in 10.6.1(f) (3) and (4), check for leaks in the gage or gage tubing.
- d) If the test under (c) is satisfactory, vent the air from the downstream mouthpiece side of the closed cylinder valve and check that the gage reading returns smoothly to zero.

Any pressure gage that is suspect after carrying out checks a, b, c, and d should be examined by a qualified person before use.

16.7.2 Maintenance

The gage should be tested at regular intervals for accuracy and water-tightness at intervals of not more than one year.

16.8 Flexible Hoses

16.8.1 General

It should be ensured that hoses are suitable for the purpose for which they are to be used. Hoses are susceptible to attack by direct sunlight, oil contamination, high temperature, humidity and seawater. Any prolonged tension on a hose increases its liability to cracking, crazing and perishing. Hoses should be carefully examined at frequent intervals and before use for signs of crazing or cracking; if this appears on the surface, bending the hose will indicate the depth of cracking. If the crack penetrates the reinforcing ply, the hose should be replaced.

16.8.2 Storage

When not being used, hoses should be stored in cool, dry conditions, and in a circulating atmosphere, if possible. It is recommended that hoses should be loosely in storage.

Fresh water rinsing and drying is recommended after use. If the hoses are to be stored for a period exceeding one month, it is recommended that they be blown through with clean, dry air before storage and again before reuse.

16.8.3 End fittings

Regular attention to metal end fittings and their attachment to the hose is advisable. Screw threads and sealing surfaces should be kept clean and any sealing washers examined and replaced, if faulty. Care should be taken to prevent water entering the interior of the hose.

16.8.4 Maintenance

The hose should be examined and pressure tested at intervals of not more than two years.

16.9 Rubber, Fabric and Plastic Components**16.9.1 General**

Rubber, fabric and plastic components of the breathing set and harness may be susceptible to attack by direct sunlight, high temperature, humidity and oil contamination.

16.9.2 Examination

The external signs of deterioration in rubber, fabric and plastic are crazing, cracking, stickiness, lack of elasticity, changes in color or signs of abrasion.

The appearance of one or more of these symptoms means that the end of the useful life of the component is very near, and it should be replaced. Particular attention should be paid to components having a thin cross section.

16.9.3 Storage

Before storage, all rubber, fabric and plastic components should be rinsed in clean fresh water after use, especially where dirty conditions (oil or sewage contamination) have been encountered. Particular care should be taken at such points as buckles, eyelets, etc., where contaminants will tend to lodge. Rubber compounds should be lightly dust treated as recommended by the manufacturer.

Storage conditions should be cool, dry, shaded, and with a circulating atmosphere. Any prolonged tension on a rubber component increases its liability to cracking, crazing and perishing; it is therefore advisable to avoid creasing as far as possible.

16.9.4 Harness

All webbing should be carefully inspected at periodic intervals for wear and tear, particular attention being paid to the stitching, fastening of buckles, etc., and to the operation of quick release devices.

16.10 Underwater Breathing Apparatus**16.10.1 General**

The corrosive action of seawater and water borne contaminants shall never be underestimated and if precautions are not taken to clean the apparatus properly after use, serious damages may be caused to all parts of the apparatus while it is stowed away. It is worth remembering that even, when diving in apparently fresh water, there may be corrosive substances in solution such as chemical and petroleum wastes which are not noticeable at the time, but which will start corrosive action if left in contact with the apparatus.

16.10.2 Cylinders**16.10.2.1 Care of cylinders**

Accessories fitted to the cylinder, even if they are plated or of stainless steel, should be insulated from the cylinder by suitable means, either a plastic or nylon coating, or a rubber sleeve.

After use of underwater BA, particularly in seawater, the cylinder should be removed from its harness and boot and then washed carefully in clean, fresh water to remove all traces of salt water and dirt, especially from any cracks. The cylinder and valve should be thoroughly dried.

To ensure the good service of the cylinder valve, care should be taken when opening and closing it to ensure that excessive forces is not applied once the stop has been reached, as this causes damage to the internal components of the valve and could result in a leak through the valve.

Before storage, or when the cylinder has been completely discharged and seawater may have entered the cylinder, the cylinder valve should be removed and the cylinder washed internally and externally in clean fresh water and thoroughly dried. This operation should normally be undertaken by an authorized person. The cylinder should not be stored with the valve downwards.

Cylinders should be retested periodically in accordance with manufacturer's recommendations.

16.10.2.2 Care after diving

The demand regulator (with the high pressure inlet blanked off) reducing valve gage and associated assemblies should be thoroughly rinsed in clean fresh water, and then allowed to dry naturally.

Artificial heat or sunlight should not be used to accelerate the drying process.

APPENDICES**APPENDIX A****COMPRESSED AIR FOR HUMAN RESPIRATION****A.1 Preparation of Compressed Air Cylinders**

Cylinders should be internally and externally clean and free of scale or other foreign matters.

A.2 Compression of Atmospheric Air

Atmospheric air may be compressed by means of suitable compressors to attain the air purity and pressure desired. Precautions should be taken to ensure that only uncontaminated air is admitted into the compressor intake. Attention should be paid to the location of the compressor intake and to the provision of suitable intake screening or filtration.

Where compressors are driven by an internal combustion engine, every care should be taken, by extending the exhaust of the engine or the inlet of the compressor, to avoid the compressor drawing in the exhaust gases of the engine. The compressor manufacturer should be consulted concerning the maximum length and the minimum cross-sectional area' of such an extension to avoid reducing the efficiency of the engine or compressor.

When compressors are being run in the vicinity of other machinery, adequate precautions should be taken to avoid intake of fumes from these machines.

The maintenance and operation of compressors should be carried out in accordance with the manufacturer's instructions, particular attention being paid to the condition of piston rings, driers, filters and accessories. No lubricant other than that recommended by the compressor manufacturer should be used.

The air discharged from the compressor should be subjected to the processes necessary to achieve the degree of purity. At regular intervals, not exceeding six months and after major overhaul, a sample of the compressed air delivered by the compressor should carefully be tested by laboratory.

APPENDIX B

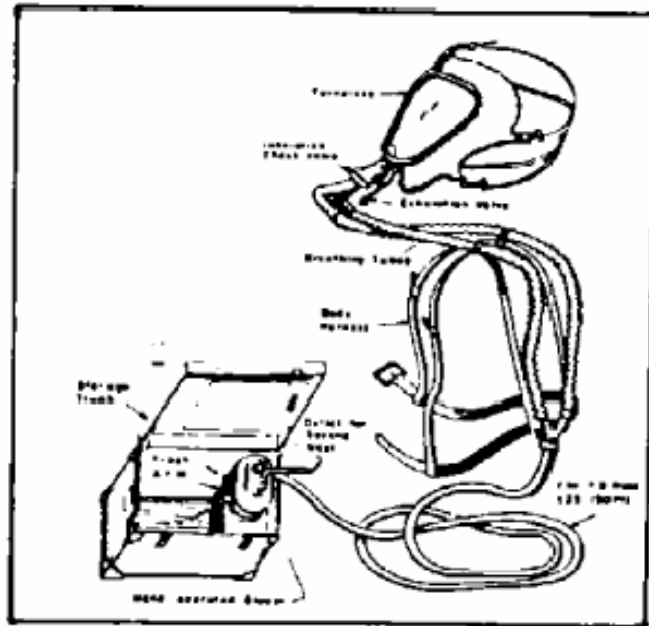

HAND OPERATED BLOWER

Fig. B.1

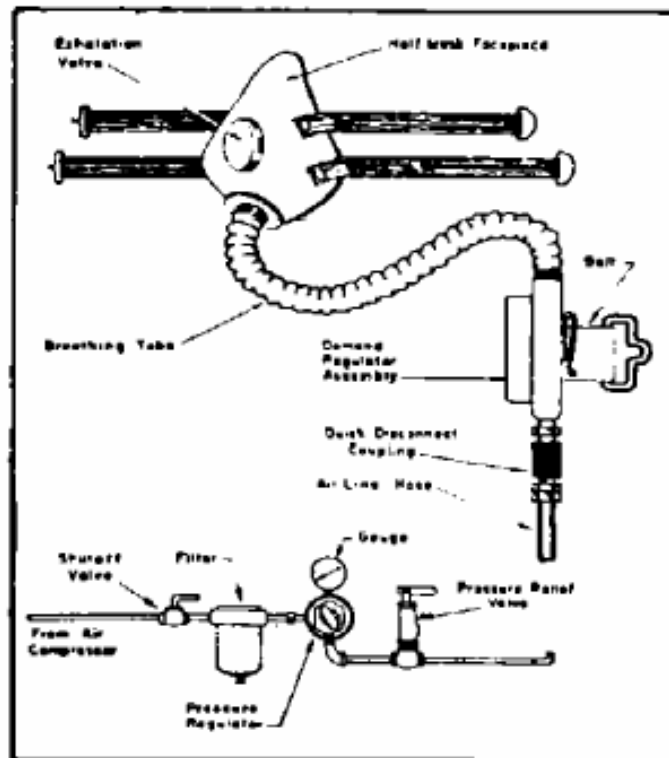

AIR LINE RESPIRATOR

Fig. B.2

APPENDIX C

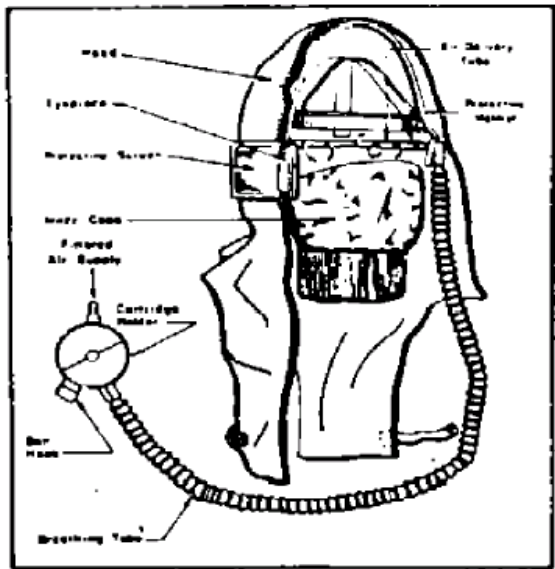

LIGHT-WEIGHT HOOD DESIGNED FOR USE BY PERSONS DOING ABRASIVE BLASTING

Fig. C.1

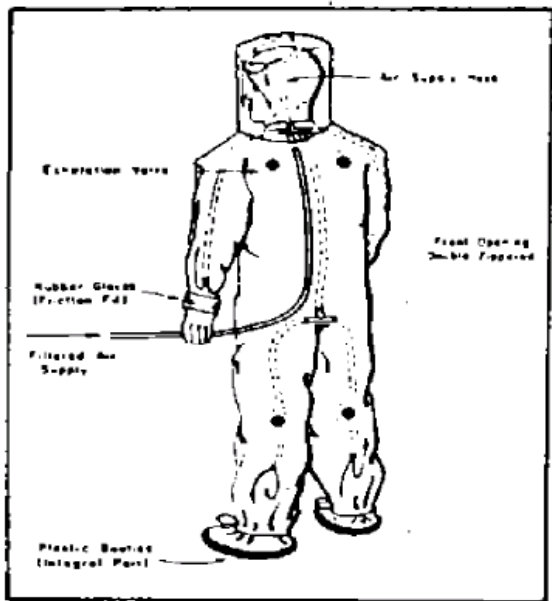
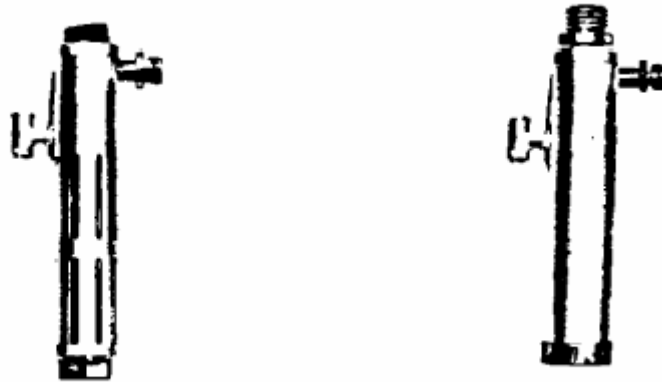

DIAGRAM OF AIR SUPPLIED SUIT FOR USE IN CORROSIVE CHEMICAL ATMOSPHERES

Fig. C.2

(to be continued)

APPENDIX C (continued)



A B

TUBE A IS CAPABLE OF PROVIDING TUBE B PROVIDES COOL AIR ONLY EITHER COOL OR
HOT AIR

Fig. C.3

FIGURES

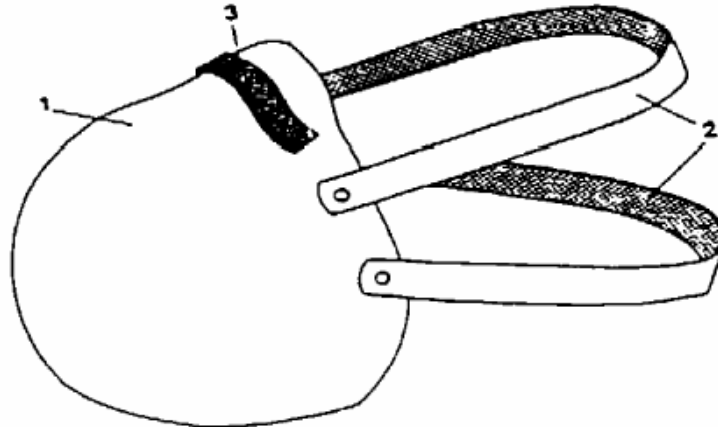

- 1) Facepiece
- 2) Head harness
- 3) Nosepiece

a) Filtering Facepiece

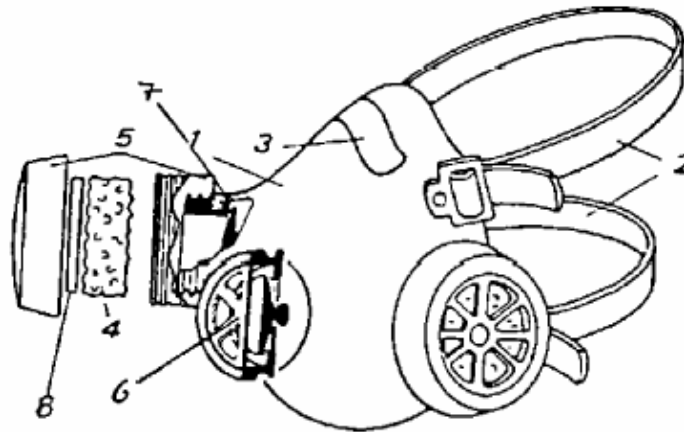

- 1) Face blank
- 2) Head harness
- 3) Nosepiece
- 4) Filter
- 5) Filter housing
- 6) Exhalation valve
- 7) Inhalation valve
- 8) Prefilter

b) Filtering Devices
Fig. 6

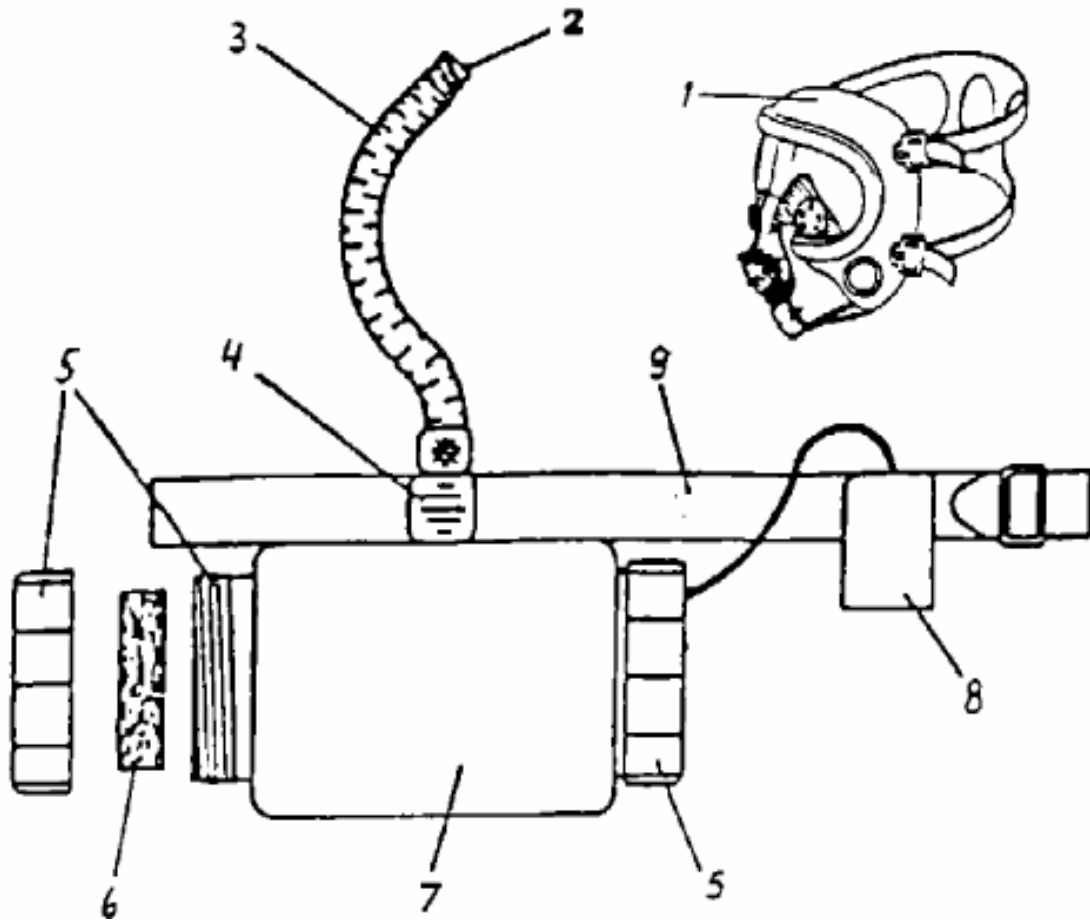

- 1) Facepiece
- 2) Equipment connector
- 3) Breathing hose
- 4) Coupling
- 5) Filter housing
- 6) Filter
- 7) Blower
- 8) Battery
- 9) Belt or carrying strap

POWERED FILTERING DEVICE
Fig. 7

- 1) Face blank
- 2) Facepiece seal
- 3) Visor
- 4) Inner mask
- 5) Head harness
- 6) Connector
- 7) Exhalation valve
- 8) Check valve
- 9) Inhalation valve
- 10) Speech diaphragm
- 11) Neck strap (Carrying strap)

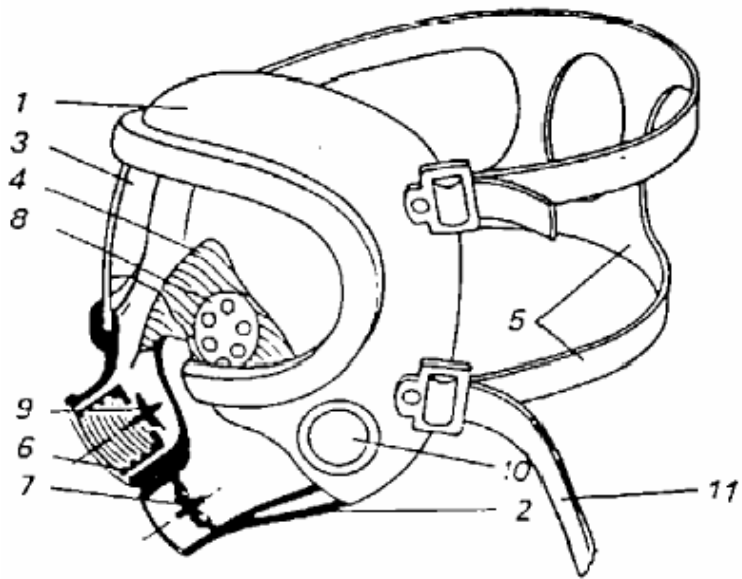

a) Facepieces Full Face Mask

- 1) Face blank
- 2) Head harness
- 3) Exhalation valve
- 4) Inhalation valve
- 5) Connector

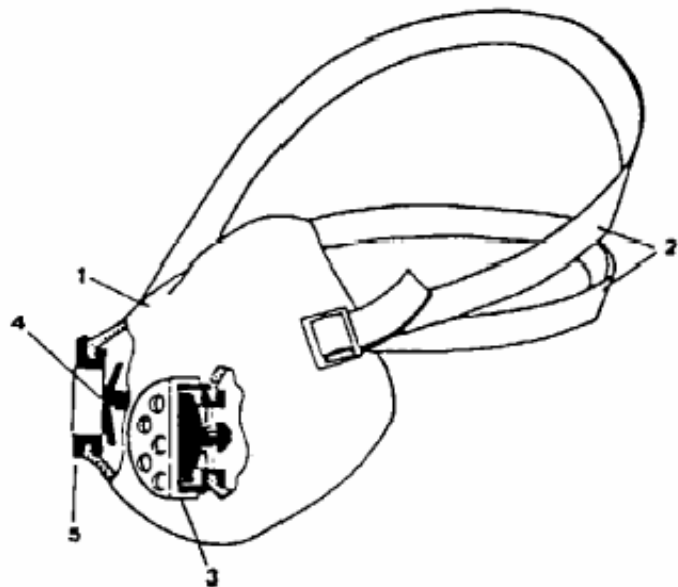

b) Half Mask
Fig. 8

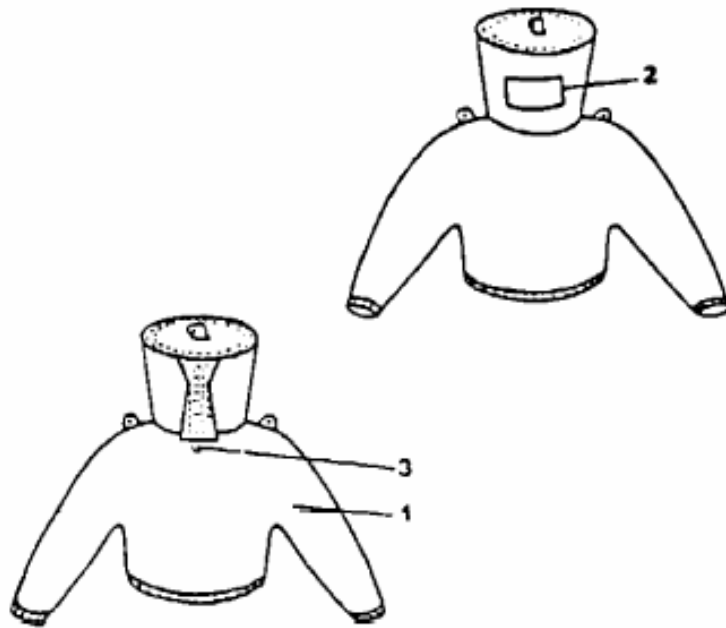

- 1) Blouse
- 2) Visor
- 3) Connector

a) Blouse

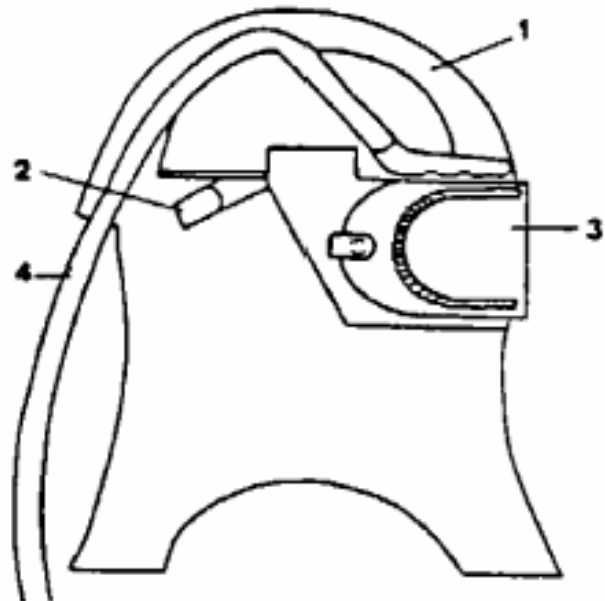

- 1) Hood
- 2) Head harness
- 3) Visor
- 4) Air supply hose

b) Hood
Fig. 9

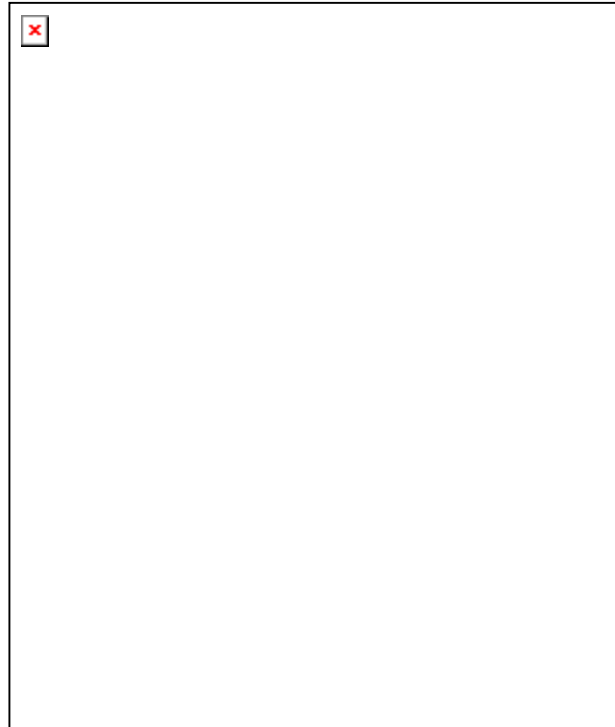

- 1) Facepiece
- 2) Equipment connector
- 3) Breathing hose
- 4) Breathing bag
- 5) Air supply hose
- 6) Coupling
- 7) Belt or body harness
- 8) Blower (Hand operated)

ASSISTED FRESH AIR HOSE BREATHING APPARATUS MANUALLY ASSISTED TYPE

Fig. 10

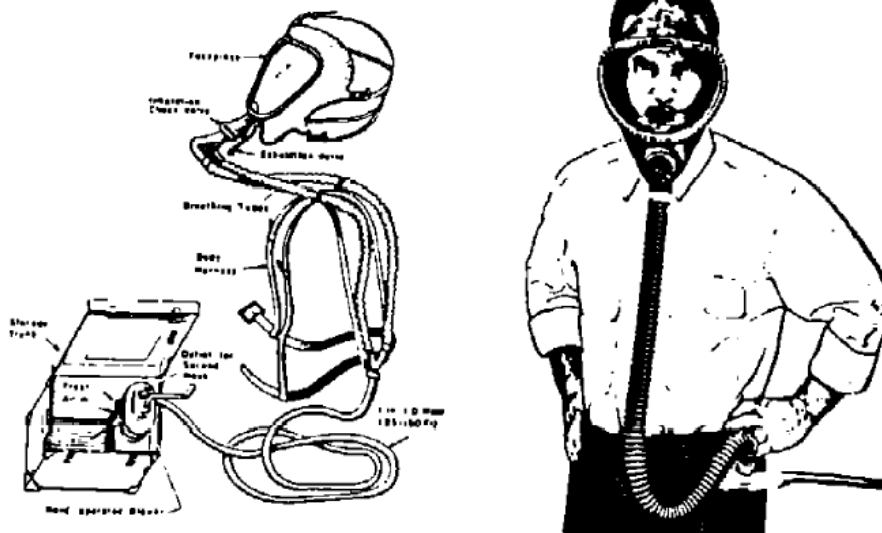

AIR LINE RESPIRATOR

Fig. 11

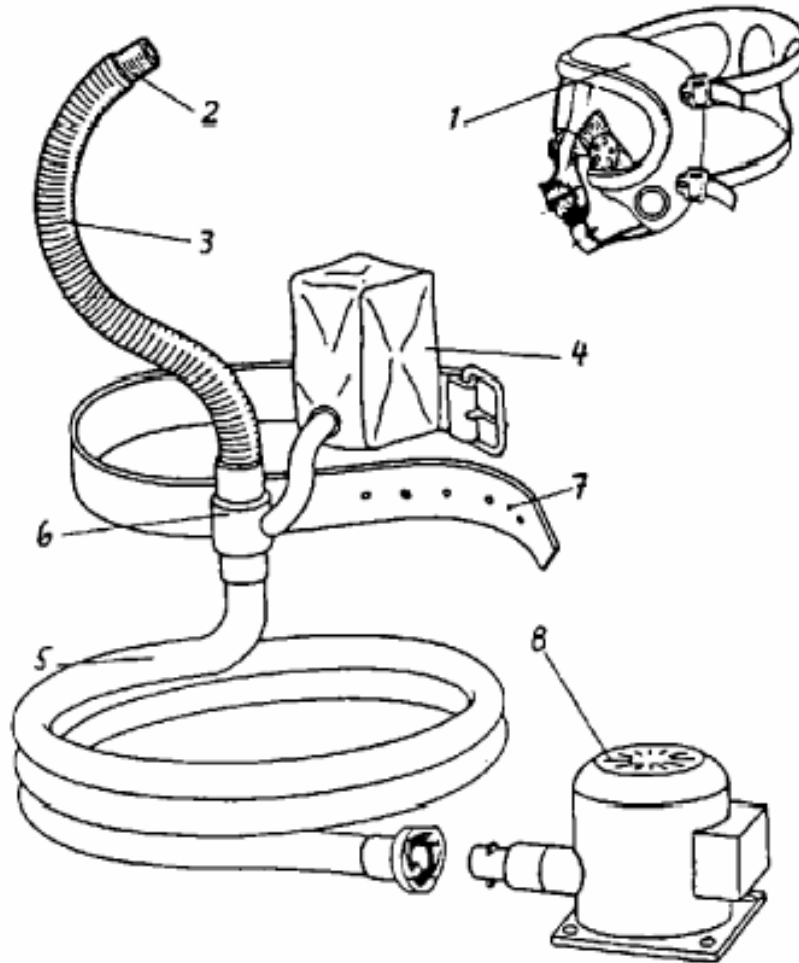

- 1) Facepiece
- 2) Equipment connector
- 3) Breathing hose
- 4) Breathing bag
- 5) Air supply hose
- 6) Coupling
- 7) Belt or body harness
- 8) Blower (Motor-driven) or compressed air injector

ASSISTED FRESH AIR HOSE BREATHING APPARATUS POWER ASSISTED TYPE
Fig. 12

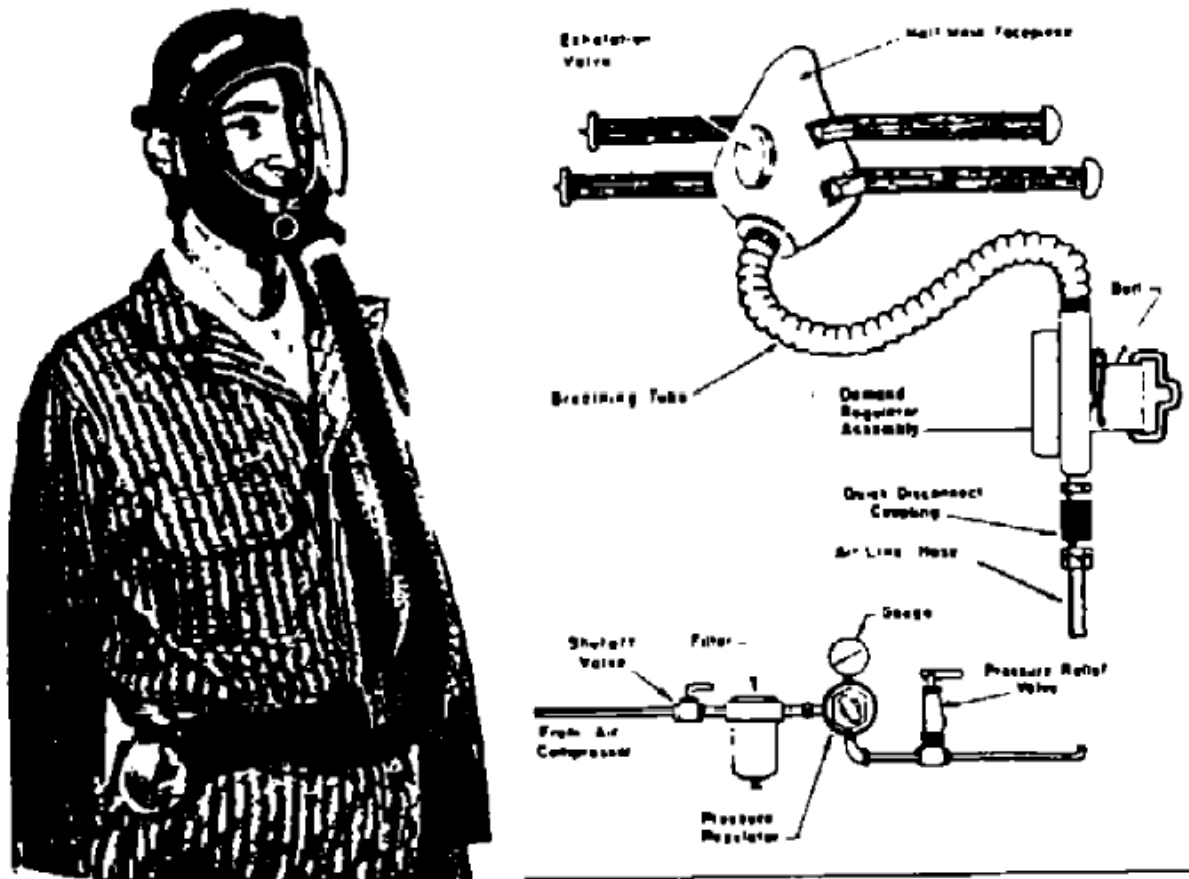

AIR LINE RESPIRATOR DIAGRAM SHOWS PARTS WITH FULL - FACE MASK
Fig. 13

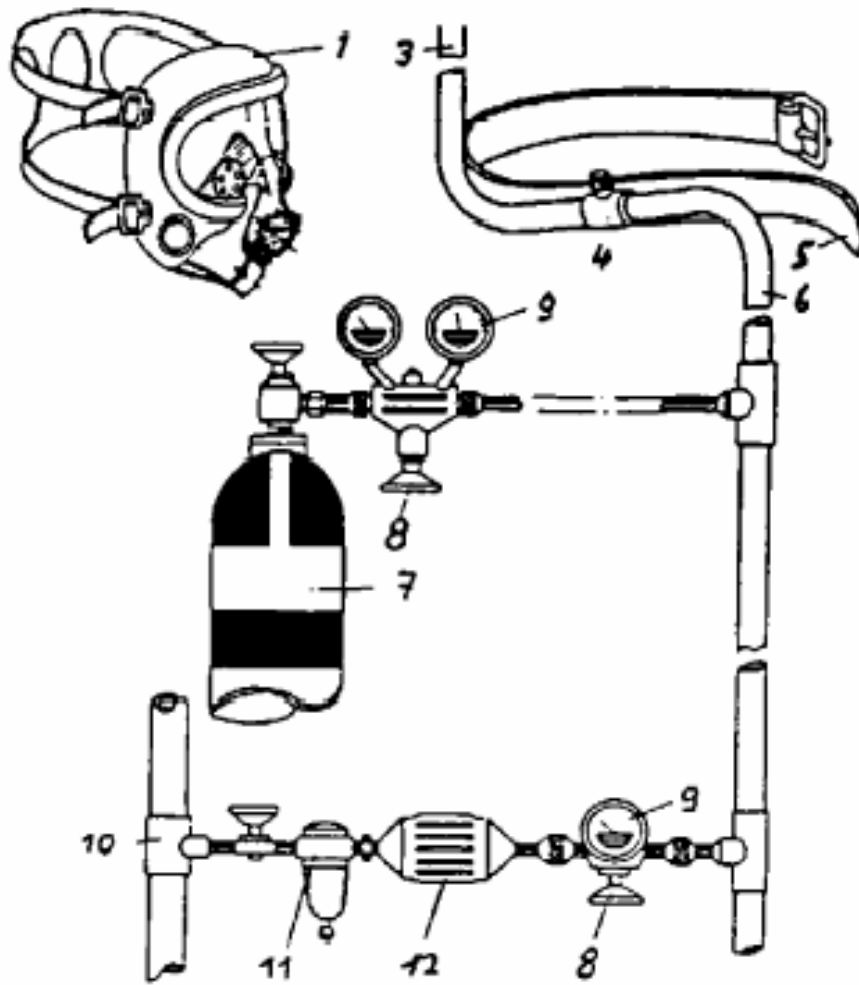

- 1) Facepiece
- 2) Equipment connector
- 3) Breathing hose
- 4) Coupling and continuous flow valve
- 5) Belt or body harness
- 6) Compressed air supply tube
- 7) Compressed air cylinder
- 8) Pressure reducer with warning device
- 9) Pressure gage
- 10) Compressed air line
- 11) Separator
- 12) Filter

COMPRESSED AIR LINE BREATHING APPARATUS CONTINUOUS FLOW TYPE
Fig. 14

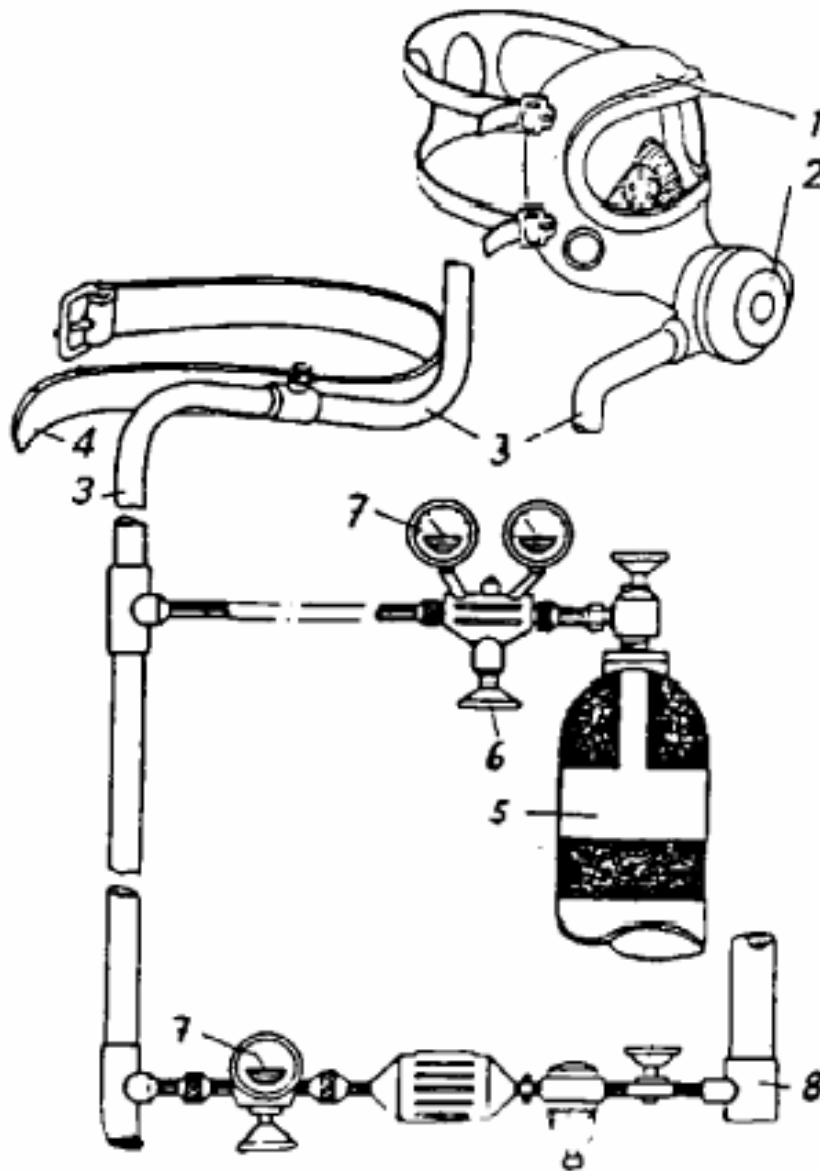

- 1) Facepiece
- 2) Demand valve (Lung governed)
- 3) Medium pressure connecting tube
- 4) Belt or body harness
- 5) Compressed air cylinder
- 6) Pressure reducer
- 7) Pressure gage
- 9) Compressed air line
- 10) Filter

DEMAND TYPE
Fig. 15

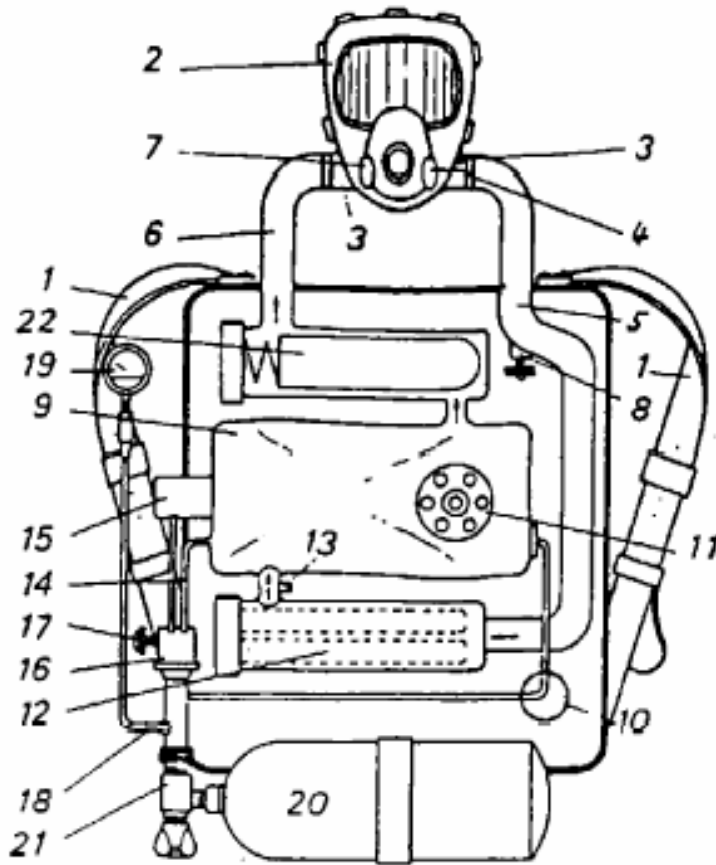

- | | |
|------------------------|---------------------------------------|
| 1) Body harness | 12) Regeneration cartridge |
| 2) Facepiece | 13) Flushing device |
| 3) Equipment connector | 14) Oxygen supply tube |
| 4) Exhalation valve | 15) Demand valve (Lung governed) |
| 5) Exhalation hose | 16) Pressure reducer |
| 6) Inhalation hose | 17) Supplementary oxygen supply valve |
| 7) Inhalation valve | 18) Pressure gage tube |
| 8) Saliva trap | 19) Pressure gage |
| 9) Breathing bag | 20) Oxygen cylinder |
| 10) Warning device | 21) Cylinder valve |
| 11) Relief valve | 22) Cooler |

SELF-CONTAINED CLOSED CIRCUIT OXYGEN BREATHING APPARATUS COMPRESSED OXYGEN TYPE

Fig. 16

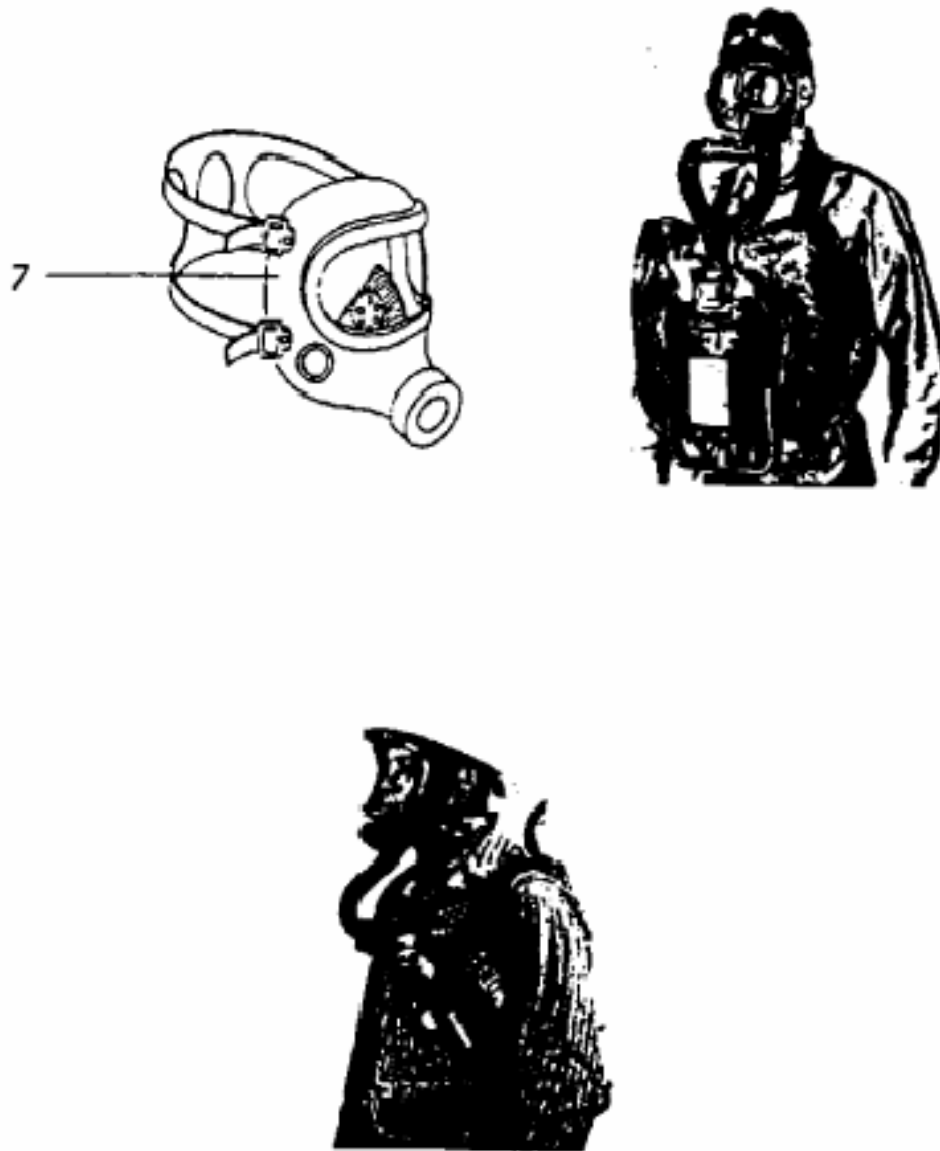

Compressed air (cylinder) nonrebreathing apparatus

OXYGEN-GENERATING (RECIRCULATING) APPARATUS, ONE-HOUR TYPE

Fig. 17

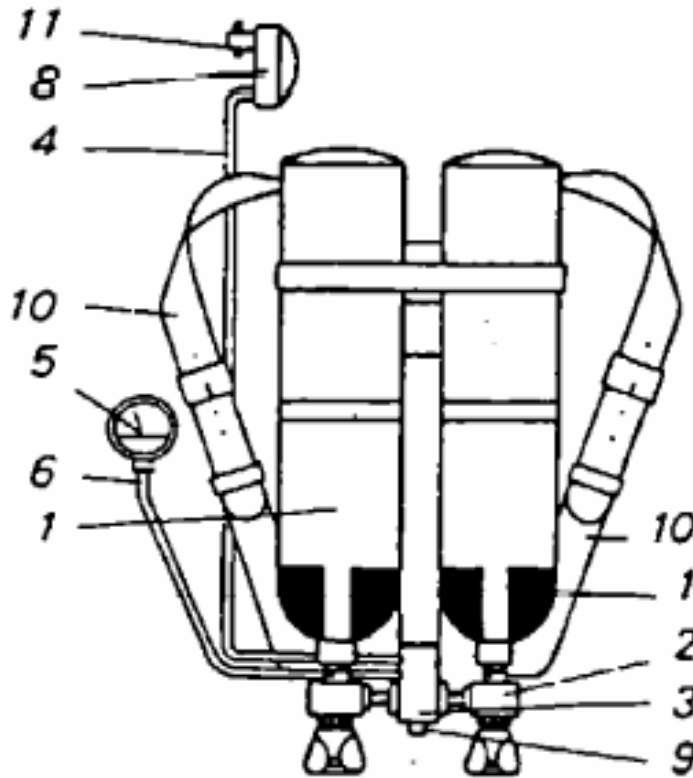

- 1) Compressed air cylinder
- 2) Cylinder valve
- 3) Pressure reducer
- 4) Medium pressure connecting tube
- 5) Pressure gage
- 6) Pressure gage tube
- 7) Facepiece
- 8) Demand valve (Lung governed)
- 9) Warning device
- 10) Body harness
- 11) Equipment connector
- 12) Breathing hose

**SELF-CONTAINED OPEN-CIRCUIT COMPRESSED AIR BREATHING APPARATUS DEMAND
TYPE
Fig. 18**