

GENERAL STANDARD

FOR

DISPOSAL OF SOLID WASTE

ORIGINAL EDITION

DEC. 1997

This standard specification is reviewed and updated by the relevant technical committee on July 2004(1) and Nov. 2012(2). The approved modifications are included in the present issue of IPS.

FOREWORD

The Iranian Petroleum Standards (IPS) reflect the views of the Iranian Ministry of Petroleum and are intended for use in the oil and gas production facilities, oil refineries, chemical and petrochemical plants, gas handling and processing installations and other such facilities.

IPS are based on internationally acceptable standards and include selections from the items stipulated in the referenced standards. They are also supplemented by additional requirements and/or modifications based on the experience acquired by the Iranian Petroleum Industry and the local market availability. The options which are not specified in the text of the standards are itemized in data sheet/s, so that, the user can select his appropriate preferences therein.

The IPS standards are therefore expected to be sufficiently flexible so that the users can adapt these standards to their requirements. However, they may not cover every requirement of each project. For such cases, an addendum to IPS Standard shall be prepared by the user which elaborates the particular requirements of the user. This addendum together with the relevant IPS shall form the job specification for the specific project or work.

The IPS is reviewed and up-dated approximately every five years. Each standards are subject to amendment or withdrawal, if required, thus the latest edition of IPS shall be applicable

The users of IPS are therefore requested to send their views and comments, including any addendum prepared for particular cases to the following address. These comments and recommendations will be reviewed by the relevant technical committee and in case of approval will be incorporated in the next revision of the standard.

Standards and Research department

No.17, Street14, North kheradmand

Karimkhan Avenue, Tehran, Iran .

Postal Code- 1585886851

Tel: 88810459-60 & 66153055

Fax: 88810462

Email: Standards@ nioc.ir

GENERAL DEFINITIONS

Throughout this Standard the following definitions shall apply.

COMPANY :

Refers to one of the related and/or affiliated companies of the Iranian Ministry of Petroleum such as National Iranian Oil Company, National Iranian Gas Company, National Petrochemical Company and National Iranian Oil Refinery And Distribution Company.

PURCHASER :

Means the "Company" where this standard is a part of direct purchaser order by the "Company", and the "Contractor" where this Standard is a part of contract document.

VENDOR AND SUPPLIER:

Refers to firm or person who will supply and/or fabricate the equipment or material.

CONTRACTOR:

Refers to the persons, firm or company whose tender has been accepted by the company.

EXECUTOR :

Executor is the party which carries out all or part of construction and/or commissioning for the project.

INSPECTOR :

The Inspector referred to in this Standard is a person/persons or a body appointed in writing by the company for the inspection of fabrication and installation work.

SHALL:

Is used where a provision is mandatory.

SHOULD:

Is used where a provision is advisory only.

WILL:

Is normally used in connection with the action by the "Company" rather than by a contractor, supplier or vendor.

MAY:

Is used where a provision is completely discretionary.

CONTENTS:	PAGE No.
0. INTRODUCTION	4
1. SCOPE	5
2. REFERENCES	5
4. UNITS	7
5. GENERAL CONSIDERATION.....	7
5.1 Types of Waste.....	7
6. SITING OF HAZARDOUS WASTE FACILITIES.....	8
6.1 Permit Requirements	8
6.2 Environmental Impacts.....	8
7. NON HAZARDOUS WASTE	9
8. SOURCES, SEGREGATION, QUANTITIES, AND CHARACTERISTICS OF SOLID WASTE IN REFINERY	10
8.1 Sources and Classification	10
8.2 Segregation of Wastes	10
8.3 Typical Quantities and Characteristics.....	12
9. SOURCE REDUCTION METHODS.....	12
9.1 Tank Cleaning.....	12
9.2 Biosludge from Water Treatment	12
10. RESOURCE RECOVERY AND WASTE MINIMIZATION	13
10.1 Resource Recovery.....	13
10.2 Minimization of Waste Generation	14
11. HAZARDOUS WASTE REDUCTION	17
11.1 Generator	18
11.2 Transporter Responsibility	18
11.3 Treatment, Storage and Disposal Facilities (TSDF)	18
12. TREATMENT PRIOR TO ULTIMATE DISPOSAL	19
12.1 Concentration	19
12.2 Sludge Concentration by Gravity Differential Method	19
12.3 Sludge Concentration by Mechanical Dewatering	20
12.4 Sludge Concentration by Incineration	20
12.5 Land Treatment of Hazardous Waste Description.....	21
13. DISPOSAL OF WASTE GENERATED IN DRILLING WELL	24
13.1 Onshore Drilling	24
13.2 Offshore Drilling.....	25
14. DISPOSAL OF PETROCHEMICAL WASTE	25
15. GENERAL SAMPLING CONSIDERATION.....	26
15.8 General Planning of Waste Sampling	26
15.9 Sampling Equipment	28
16. AIR MONITORING OF WASTE FOR EMPLOYEES PROTECTION.....	31
17. PROCEDURES	32
18. HAZARDS	34
19. QUALITY ASSURANCE CONSIDERATION	34

0. INTRODUCTION

In Oil, Gas and Petrochemical Industries, solid waste has become more complex and consequence of improper disposal techniques more severe.

To achieve compliance with environmental pollution criteria the following steps shall be considered:

- 1)** An effective waste program to conduct a solids survey to find problem of waste quantities, characteristics, sources, cost and disposal options.
- 2)** Establish ways and means for segregation, waste reduction and resource recovery.

1. SCOPE

This Standard gives general description as a minimum requirement for procedure of solid waste disposal and covers many aspects such as:

Types, hazard, nonhazard, siting, sources, segregation, reduction, resource recovery, treatment sludge concentration and sampling equipment. It does not provide all of the detailed information that is needed for design and operation of solid waste system. There shouldn't be any conflict between this standard and Iranian waste management law, unless other wise specified and approved by owner.

Note 1:

This standard specification is reviewed and updated by the relevant technical committee on July 2004. The approved modifications by T.C. were sent to IPS users as amendment No. 1 by circular No. 229 on July 2004. These modifications are included in the present issue of IPS.

Note 2:

This standard specification is reviewed and updated by the relevant technical committee on Nov. 2012. The approved modifications by T.C. were sent to IPS users as amendment No. 2 by circular No. 358 on Nov. 2012. These modifications are included in the present issue of IPS.

2. REFERENCES

Throughout this Standard the following dated and undated standards/codes are referred to. These referenced documents shall, to the extent specified herein, form a part of this standard. For dated references, the edition cited applies. The applicability of changes in dated references that occur after the cited date shall be mutually agreed upon by the Company and the Vendor. For undated references, the latest edition of the referenced documents (including any supplements and amendments) applies.

IPS (IRANIAN PETROLEUM STANDARDS)

IPS-M-SF-325	"Material and Equipment Standard for Personnel Safety and Fire-Fighters Protective Equipment"
IPS-E-PR-735	"Engineering Standard for Process Design of Plant Solid Waste Treatment and Disposal Systems"
IPS-E-SF-880	"Engineering Standard for Water Pollution Control"
IPS-E-GN-100	"Engineering Standard for Units"

SOURCES

- OSHA Interim Final Rule for Hazardous Waste Operations and Emergency Response
- Recommended Practice D 1605 ASTM
- Annual Book of ASTM Standard Volume 11.03
- NIOSH Manual of Analytical Methods
- OSHA Analytical Method Manual
- United State Resource Conservation and Recovery Act (RCRA) and Hazardous Solid Waste (HSWA)

ASTM (AMERICAN STANDARD FOR TESTING OF MATERIALS)

ASTM D 4057	“Standard Practice for Manual Sampling of Petroleum and Petroleum Products”
ASTM D 4687	“Standard Guide for General Planning of waste Sampling”
ASTM D 4844	“Standard Guide for Air Monitoring at Waste Management Facilities for Worker”
ASTM E 300	“Standard Practice for Sampling Industrial Chemicals”

3. DEFINITIONS AND TERMINOLOGY**Solid Waste**

Solid waste is any garbage, refuse, or sludge, water supply treatment plant, or air pollution control facility, or other discarded material, including solids, liquids, semisolids, or contained gaseous material resulting from industrial, commercial, mining, and agricultural operations and from community activities. In addition, solid waste does not include radioactive source, special nuclear, and/or their by-product material and etc.

Discarded Material

Discarded material is used or spent material which is not reused in any way and this is committed to final disposition.

Hazardous Waste

Hazardous waste is solid waste which poses specified health and safety and environmental hazards. Consist of toxicity, flammability, corrosivity and reactivity and infectious.

Disposal

Disposal is the discharge, deposit, injection, dumping, spilling, leaking, or placing of any solid waste or hazardous waste into or on any land or water so that such solid waste or hazardous waste or any constituent thereof may enter the environment, be emitted into the air, or be discharged into any waters, including ground waters. Therefore, waste deposited in a landfill, landfarmed wastewater discharged to a basin or surface impoundment, or stormwater run-off diverted to a percolation or settling pond is disposal.

An Open Dump

An open dump is a facility that does not meet the criteria for a sanitary landfill and is not a facility for disposal of hazardous waste.

Contamination

Contamination is any substance which would cause the concentration of that substance in the groundwater to exceed the maximum contaminate levels.

Operating Site

An operating site is a location or facility where waste is treated, stored, or disposed as part of an on-going operation.

Remedial Action Site

A remedial action site is a location or facility that may pose a threat to human health and the environment.

4. UNITS

This Standard is based on International System of Units (SI), as per [IPS-E-GN-100](#) except where otherwise specified.

5. GENERAL CONSIDERATION

5.1 Types of Waste

- a) Hazardous Wastes.
- b) Non-Hazardous Wastes.

5.1.1 Hazardous wastes

Hazardous wastes cover the following units and complexes:

- Refinery waste.
- Petrochemical industry waste.
- Fertilizer industry waste.
- Chemical industry waste.
- Desalting plant and production unit.
- Other Part of oil and gas industries

5.1.1.1 Refinery waste

The following typical general refinery wastes are considered as hazardous:

- a) Neutralization hydrofluoric alkylation sludge.
- b) Dissolved air floatation unit sludge.
- c) Kerosine filter cake.
- d) Lube oil filtration clays.
- e) Slop oil emulsion solids.
- f) Exchanger bundle cleaning.
- g) API separator sludge.

5.1.1.2 Petrochemical industry waste

Sources of solid wastes in petrochemical industries are as follows:

- Plastic, rubber.
- Waste catalysts.
- Activated carbon, Japanese acidclay, zeolite.
- Alkali waste (soda, amine) and waste acid.
- Vinyl chloride tar.

- Oil sludge.
- Tar, resin, pitch, sludge.

5.1.1.3 Fertilizer industry waste

Phosphatic fertilizer industry solid waste By-Product Phospho-Gypsum (BPG) generate in fertilizer industry. Only 20% of total BPG is used for producing ammonium sulfate, the reminder being released to Land-fill or lagooning in slurry form. The general characteristic of BPG and toxic metal constituents are given in Table 1.

TABLE 1 - COMPOSITION OF BPG

CONSTITUENTS	PERCENTAGE DRY WEIGHT
CaSO ₄ , 2H ₂ O	90.0 - 95.0
Water of crystallization	19.0 - 20.0
Total phosphate (PO ₄)	0.8 - 1.6
Total fluoride (F)	0.5 - 1.9
Sodium + potassium (Na ₂ O + K ₂ O)	0.5 - 1.0
Silica (SiO ₂) and other insolubles	2.0 - 3.0
Organic matter	0.4 - 0.8
Toxic constituents	mg/kg dry weight except radioactivity
Cadmium (Cd)	1.25 - 3.22
Chromium (Cr)	1.47 - 1.72
Copper (Cu)	4.00 - 4.76
Lead (Pb)	6.37 - 6.47
Manganese (Mn)	5.48 - 10.39
Radioactivity	29 p Ci/gm dry weight

5.1.1.4 Solid waste from chemical industry

Pesticides

DDT and BHC (Benzen Hexa Chloride) are the commonly used pesticides. Organo phosphorous and carbonate are the other pesticides. In the process, waste water releases highly corrosive substances (pH 1-1.7), containing DDT, sulphuric acid and suspended solid. The waste waters are neutralized with lime and the setteled effluent still contains DDT.

In production of Benzen Hexa Chloride (BHC) about 30 m³ waste water per ton of BHC containing 0.4 BHC is released which is highly corrosive and toxic (pH 2.6-3.0).

Lime neutralization and sludge drying in sand bed can be exercised. About 90% of BHC in wastewater goes into the sludge.

Concentrated, unused pesticides should be stored, returned or disposed off as toxic waste.

6. SITING OF HAZARDOUS WASTE FACILITIES

6.1 Permit Requirements

Every facility that treats, stores, or disposes hazardous wastes shall obtain a permit from Environmental Protection Organization to approve the site selected for operation of the facilities mentioned.

Details of all aspects of design, operation and maintenance must be described in the permit and show compliance with the applicable requirements.

6.2 Environmental Impacts

Environmental impacts include potential effects on ecological processes, on human health, and on

the esthetics of the natural and cultural landscape. For any given facility, these impacts will depend on the volumes and types of wastes to be managed; on the design and operation of the facility.

Table 2 lists examples of potential environmental impacts that should be considered, taking into account both expected and possible accidental effects from each element of the facility's operation (e.g., transport, storage, treatment, incineration). Environmental impacts in the absence of a facility should also be adhered if the facility will in fact help to remedy disposal practices currently in use that are more hazardous. That point should be made and factually supported. Safeguards to prevent or mitigate such impacts should also be kept in mind.

TABLE 2 - EXAMPLES OF POSSIBLE ENVIRONMENTAL IMPACTS

<p>Groundwater contamination Surface-water contamination Air pollution Leaks, spills, accidents Destruction of wildlife habitat, natural areas, wetlands Loss of any unique site features (e.g. archaeological) Permanent contamination of site Contamination of nearby crops, fisheries Traffic congestion Odors Noise Visual ugliness Effects on character of community: magnet for other heavy industry, image as dumping ground</p>

7. NON HAZARDOUS WASTE

7.1 Drilling Fluid (Mud)

Function of drilling fluids:

- a)** Remove drilled solid (cuttings) from the bottom at the hole and carry them to the surface where they are removed;
- b)** Lubricate and cool the drill bit and string;
- c)** Control downhole pressure;
- d)** Deposit an impermeable wall cake on the well bore wall to seal the formations being drilled so contaminants do not enter the mud and the fluid phase at the mud does not enter the formation.

7.2 Nature of Drilling Discharge

The solid concentration discharge ranges from 60-90 percent by weight when drilling a very shallow onshore well. The total volume of mud discharged may be 119 m³ (1000 barrels) or less. Very deep onshore wells drilled over long period of time may generate up to 3570 m³ (30,000 barrels) of mud.

For offshore wells the volume of mud discharged ranges from 119 m³ to 595 m³ (1000 to 5000 barrels) for a typical well.

7.3 Environment Effect

7.3.1 Environment effects of drilling discharge onshore:

- a)** Excess soluble salts and high exchangeable sodium percentages are the major inhibiting effects of drilling muds to plants and soils.

- b) Most drilling muds cause soil dispersion resulting in surface crusting. Proper treatment can minimize or eliminate these effects.

8. SOURCES, SEGREGATION, QUANTITIES, AND CHARACTERISTICS OF SOLID WASTE IN REFINERY

There are numerous sources and types of refinery solid waste. Most wastes can be segregated at the source for more efficient handling before reclamation or disposal.

Because of varied refinery configurations, each refinery will have problems specific to its location, process, and local regulations. Even considering the individuality of refineries, there are basic waste materials produced which are common to most refining processes and, therefore, can be handled similarly for resource recovery or disposal. Besides these basic wastes, there are other wastes with characteristics and in quantities not easily defined. A list of waste sources and classification of wastes is presented in Table 3. Obviously such a list cannot be all inclusive.

8.1 Sources and Classification

Some of the more easily defined waste materials found in Table 3 are listed by refinery unit source and classified into combustibles, noncombustibles and biodegradables.

8.2 Segregation of Wastes

By studying Table 3 and relating it to a particular operation, prudent segregation practices that can reduce the cost and effort of handling become apparent. The following categories for segregation are to be considered:

- 1) Oily process sludges;
- 2) Nonoily wastes;
- 3) Biological sludges;
- 4) Miscellaneous;
- 5) Sanitary wastes.

TABLE 3 – A TYPICAL SOURCES AND CHARACTERISTICS OF REFINERY SOLID WASTES

Source	Combustible	Classification Noncombustible*	Biodegradable
Refining Processes			
Crude oil storage	Wax bottoms	Sand, rust, slit	
Product storage		TEL. sludge, sand rust, silt	
Crude processing		Sand, rust, silt, salt, slop oil emulsions	
Thermal cracking	Separator coke		
Catalytic cracking		Spent catalyst	
Catalytic reforming		Spent catalyst	
Polymerization		Spent catalyst	
Alkylation		Corrosion products (sludge, tar)	
HF alkylation		Calcium fluoride sludge	
Asphalt manufacture	Asphalt drips	Asphalt emulsions	Emulsions, light solven
Cooling	Coke fines, wax tailings		
Product treating	Acid sludge	Lead sludge	
	Adsorbents	Adsorbents	
Lubes and grease	Soaps	Clay	
Wax	Slops, drips		
Service Functions			
Shops			
Carpenter	Wood	Metal scrap	
Welding		Metal scrap	
Machine		Metal scrap	
Maintenance		Metal scrap, insulation	
Electrical	Rubber, plastic	Metal scrap	
Cafeteria	Waste paper	Broken glassware cans, bottle	Garbage
Laboratory	Waste paper, asphalt, Samples, boxes	Scrap equipment, catalyst	Sanitary wastes
Office	Waste paper, boxes	Scrap equipment	Sanitary wastes
Locker rooms	Waste paper, discarded clothing		Sanitary wastes
Nonrefining Operations			
Utilities			
Steam generation		Boiler blowdown sludge	
Feedwater treatment		Lime sludge	
Cooling towers		Suspended solids	
Wastewater Pollution Control			
API separators	Oily sludges, heavy hydrocarbon	Sand, silt	Oily coated inert solids
Air flotation	Oily froth		
Clarifiers	Bio. floc ^b	Flocs.	Bio floc.
Flocculation	Floc.	Clay	
Filters		Filter cake	
Biological oxidation	Bio. floc.		Bio. sludge
Air Pollution Control			
Bag filters		Catalyst dust	
Electrostatic precipitators		Catalyst dust	

a) In many cases the noncombustibles are associated with combustibles and the whole mass must be processed to remove the combustible before disposal of the inert residue.

b) Biological flocculation.

8.2.1 Oily process sludges

Oily sludge is the most difficult task to handle. Oil sludges are obtained as sediments from storage tanks, crude desalters, sewer cleaning, vessel cleaning, oil-water separators, dissolved air flotation, lube oil processing, and alkylation. A very thorough study is required to determine which wastes are compatible for mixing prior to recovery.

8.2.2 Nonoily wastes

Nonoily wastes are much easier to handle. These wastes come from storm sewer cleanings, grit chambers, tank cleaning, cooling tower cleanings, water treating, and catalyst replacement. Used catalyst is the most likely material for resource recovery.

8.2.3 Biological sludges

Biological sludges are those obtained from biological wastewater treatment plants. These sludges are concentrated by various methods, and when the quality allows, may be used as soil conditioners.

8.2.4 Miscellaneous waste

Miscellaneous solid waste materials not related to oil processing can generally be disposed of in municipal landfills.

8.2.5 Sanitary wastes

The sanitary sewage collection and disposal system should be segregated from the process wastewater system to eliminate the requirement to chlorinate the treated water effluent. Where refineries do operate sanitary waste treatment systems, adequate information is available in the literature to answer solids disposal questions.

8.3 Typical Quantities and Characteristics

Major sources of metallic constituents in refinery are API separator bottoms, dissolved air flotation units, waste biological sludge, storm silt, and waste Fluid Catalytic Cracking (FCC) catalyst. Metallic content of wastes varies widely between refineries. The metals in solid waste are, zinc, vanadium, selenium nickel, mercury, lead, copper, chromium, arsenic and cadmium.

9. SOURCE REDUCTION METHODS

For source reduction, modification of process and operating procedures should be considered. This is done to reduce the quantity of waste solid and to alter their characteristics. Some source reduction techniques are as follows:

9.1 Tank Cleaning

Variable angle mixers installed in storage tanks can be used in conjunction with selected solvents (such as, crude, light cycle oil, and water) to reduce the time, manpower, and cost of removing residual solids from storage tanks.

The selected solvent is added to the tank to be cleaned and the mixers are operated for 5 to 15 days in various positions typically ranging 30 degrees from either side of the center line. This sweeps all parts of the tank floor and lifts the solids so that solvent and oily solids are in intimate contact. The resulting deoiling of the solids recovers valuable hydrocarbon for reuse. It also reduces the oil content of the residual solids making them less difficult to dispose of ultimately and reduces the quantity of residual solids by removing the oil and wax content of the solids. An additional advantage of this technique is the greater safety afforded by conducting the major portion of the cleaning activity from outside of the tank.

9.2 Biosludge from Water Treatment

Several techniques are available to reduce the quantity of waste biosludge from wastewater treatment.

9.2.1 Sludge age

The sludge age in the biological treatment system can be increased. To accomplish this without creating sludge settling problems usually requires careful pretreatment to remove colloidal material in the wastewater entering the biounit. Removal may be accomplished by use of a well-operated air flotation or sand filter system. The sludge age can usually be increased sufficiently to reduce sludge wastage to very low levels.

9.2.2 Aerobic digestion

Aerobic digestion of the waste biosludge will result in a significant reduction in the quantity of sludge. It is also a necessary pretreatment step for landfarming of biological sludge to prevent odor problems.

9.2.3 Hydrolysis

Other methods of reducing waste biological sludge include chemical treatment, such as acid treatment, to break down the biological cell wall. Thus, organics can be oxidized and the resultant biological sludge is more easily dewatered for ultimate disposal.

9.2.4 Air floatation float recycle

Air floatation units are usually operated with chemical additives to improve their efficiency. Alum, ferric chloride, lime, and polyelectrolytes are typical chemical agents used. If possible, the chemical usage should be limited to polyelectrolytes since alum, lime, and ferric chloride type treatment creates a significant volume of oily solids for disposal. The use of polyelectrolytes alone opens the possibility of recycling the float, which is now primarily oil, to the front of the system thus reducing the quantity of solid material for disposal.

9.2.5 Beneficial combination

Some wastes may be combined to advantage. For instance, lime from boiler feed water treatment can be used for pH control on landfarm operations.

9.2.6 Emergency planning

The environmental department should be involved in the planning for all types of shutdowns or any type of emergency cases so that the quantities and characteristics of wastes to be generated by the shutdown are anticipated. The shutdown planning should assure that all possible steps are taken to keep quantities to a minimum, to control the characteristics of the waste to simplify its disposal, and to plan the disposal techniques to be used.

10. RESOURCE RECOVERY AND WASTE MINIMIZATION

10.1 Resource Recovery

The main items which are recoverable and reusable include oil, catalyst, acids, caustics, digested biological sludges, filter clays, and, in some cases, chromate inhibitors used in cooling tower treatment. Almost every refinery can identify recoverable items from waste generated by processes which are individual to that refinery.

10.1.1 Oil reclamation

All refineries practice the recovery of waste oils to some degree. The recovered oils may be reintroduced into various process feed streams or sold directly for fuel or other uses. The

techniques for recovery include simple gravity separation, emulsion breaking with chemicals and heat, and the use of lighter oils and solvents to aid in emulsion breaking and thinning of heavier oil fractions. After the oil is recovered, the residual waste is amenable to landfarming as the ultimate method of disposal. If a sludge is to be landfarmed, oil should be recovered until the oil content is no more than 15 percent. Since oil concentration is a limiting factor for the quantity of waste to be applied to a plot of land, the less oil a waste contains the smaller the land area required for landfarming.

10.1.2 Catalyst reuse

The metal content of many catalysts is frequently of sufficient quantity to allow the catalysts to be reprocessed for resale or metal recovery.

Most spent catalysts are stable enough that ultimate disposal can be accomplished by landfilling. It is a good practice not to mix spent catalyst with other wastes in a landfill. In many cases, landfills become acceptable means for disposal if they are dedicated completely to a particular waste material.

10.1.3 Acids and caustics

Waste materials should be neutralized prior to disposal. Reacting waste chemicals in this manner reduces the amount of fresh chemical required for neutralization and can be defined as a reuse process.

Neutralized acid and caustic solutions can be discharged into the wastewater treatment system whenever the total dissolved solids limit is not exceeded. Spent alkylation acid can be returned to sulfuric acid manufacturers for reprocessing.

10.1.4 Biological sludges

Biological sludge should not be used for growing food products but waste sludge may be spread in tank farm areas.

10.1.5 Filter clays

Filter clays used for oil and wax purification can be regenerated in multiple hearth furnaces for reuse. A particular clay will withstand several regeneration cycles before particle size and reaction surface deteriorate. Waste filter clay is nonreactive and is amenable to landfill as an ultimate disposal method.

10.1.6 Chromate inhibitor reuse

Chromate continues to be one of the most effective corrosion inhibitors for cooling systems. Because of restrictions, the reduction of chromium content in wastewater has become imperative. Chromate can be recovered from cooling tower blowdown for reuse in the make-up water. This is accomplished by the ion exchange process. Stringent wastewater regulation have made this reuse process more attractive.

The refinery engineer must always consider reuse waste materials in the design and development of refining processes. Maximum resource recovery might be the difference between success or failure for a particular project.

10.2 Minimization of Waste Generation

Waste minimization is very often economically beneficial for an industry and also results in improved environmental quality. The following requirements shall be considered:

10.2.1 Design and operating features for waste minimization

10.2.1.1 Integrated units

Separated components of crude can pass from one unit to the next with little or no intermediate tankage. This reduces the amount of sludge generated from intermediate storage capacity.

10.2.1.2 In-line blending

95% of all prime fuels can be blended into a pipeline as opposed to blending into tankage. Sludge generated from finished product tankage would be minimal.

10.2.1.3 Crude tank mixers

The crude oil tanks at the refinery should be equipped with mixers. The use of mixers prevents the deposit of settleable solids and thereby reduces the frequency for cleaning.

10.2.1.4 Air cooler maximization

Over 70% of the cooling in the refinery should be through air fans as opposed to water-cooled heat exchangers. This reduces potential contamination of cooling water with process fluid. It reduces the volume of cooling water make-up and cooling water in circulation. In addition, this also minimizes the generation of heat exchanger tube bundle cleaning sludge by substituting air coolers for heat exchangers.

10.2.1.5 Use of demineralized clarified river water

This technique reduces the cooling blowdown stream, thereby minimizing the generation of cooling tower treatment sludge.

10.2.1.6 Closed cooling water system

This concept uses a cooling tower system to recirculate the same volume of water for cooling purposes. This further minimizes the volume of water that could be contaminated with process fluids, and the blowdown of significant quantities of cooling water treatment chemicals, e.g., Cr and Zn.

10.2.1.7 Amine degradation prevention

In refinery which uses DEA (Di-Ethanol Amine) to absorb H_2S and CO_2 acid gases from sour gas streams, DEA forms certain nonregenerable compounds requiring occasional disposal of amine and consequent replacement with fresh amine. To reduce amine disposal, the refinery should use continuous slip-stream filtration in addition to carbon filtration to remove degradation products. In addition to filtration, additives should also be injected into the amine to inhibit deterioration.

10.2.1.8 Separate sewer systems

In refinery sewer design, segregation of all sources is recommended. All non-oily aqueous wastes can be transported via separate sewer systems. The oily aqueous wastes should be transported to API separator. The segregated sewer design reduces the load on the API separator, thereby increasing its efficiency and minimizing potential formation of API separator sludge from solids of nonhazardous origin.

10.2.1.9 Forebay skimming of API separator

A slot skimmer should be installed at the head of the API separator to recover as much oil as possible from the separator influent for direct recycle to the refinery. This technique is an oil recovery/recycle process that reduces the oil loading on the separator and decreases the amount of oily sludge generation.

10.2.1.10 Pressurized air operation of DAF unit

DAF (Dissolved Air Flootation) unit sludge generation is minimized by using the pressurized air method of operation which concentrates the DAF sludge and minimizes the quantity generated and handled.

10.2.1.11 Independent parallel bay separator design

The refinery's API separator should be in a three-bay parallel design with flexibility and capacity so that individual bays can be taken out of service for maintenance without affecting separator efficiency.

10.2.1.12 Coke fines recovery/reuse

The delayed coking unit produces anode-grade coke as a product. Coke fines are generated by the process on an intermittent basis. Instead of segregating the fines as a waste product, the refinery recovers this material and recycles it for sale along with the marketable product. This minimizes a waste-stream generation. In addition, the coke fines handling equipment design prevents coke solids introduction into the oily water sewer system and its eventual deposition at the bottom of the API separator as an sludge.

10.2.1.13 Process catalyst reuse, reclamation, recovery

The refinery utilizes catalyst wherever possible that can be reclaimed, recovered or reused in the various processing operations.

10.2.1.14 Spent naphthenic caustic reuse

A unit should be installed to process spent naphthenic caustics into naphthenic acids for sale as a by-product.

10.2.1.15 Slop-Oil recovery/reuse

All slop oils generated should be collected and directed to the crude unit and coker for recovery and production of fuels and petroleum products. This minimizes the sewerage of oily materials and production of API separator sludge and slop oil emulsion solids.

10.2.1.16 Paving of process areas to minimize solids (mostly dirt) entering the refinery oily water sewer system. These solids would otherwise be removed from the API separator as hazardous waste.

10.2.1.17 Use of the contract filtration services to dewater/deoil wastewater treatment sludges prior to land treatment. By reducing the volume and oil content of these sludges, further land treatment operation can be conducted in a smaller area and at lower oil loading rates and the oil is recovered/reused in the refinery.

10.2.1.18 Installation of an air operated skimmer at the head of the API separator to complement existing mechanical skimmer and further enhance oil recovery from the separator inflow. This results in further reducing the oil loading on the separator and subsequent formation and disposition of oily sludges that would be removed as hazardous waste.

10.2.1.19 The refinery is conducting an assessment of various additives that can be added to heat

exchangers to reduce the current deposit rates. These deposits would eventually be removed as hazardous waste.

10.2.1.20 Replacement of sludge storage impoundments with aboveground tankage. The tank system includes a mixing tank plus two storage tanks. The system will use heat and chemical addition to remove oil and water from the sludges as an initial step in reducing the volume and oil content of the wastes. These tanks will also eliminate water accumulation in the sludges from rainfall and volatile hydrocarbon air emissions from the sludges.

10.2.1.21 A filtration service dewater biological solids generated by the secondary treatment system. The waste biosludge has a very high water content and is dewatered prior to disposal on the land treatment area. Instead of acting as a hydraulic gradient to promote contaminant migration through the treatment zone, the dry bio-sludge serves to augment the existing land farm micro-organisms in waste assimilation and fixation.

10.2.1.22 The refinery should try to sell spent FCC catalyst for use in the manufacture of Portland cement, in lieu of landfill disposal.

10.2.1.23 An effort should be made to keep surfactant materials out of the sewers to minimize formation of oil-in-water emulsions that create oily sludges (e.g., API separator bottoms, slop oil emulsion cuff and DAF float).

10.2.1.24 Secondary containment should be provided for all intermediate and final product transfer tankage pumps. This measure prevents potential soil contamination in case of a leak or spillage.

10.2.1.25 A reclaimer for scrap metal to be used.

10.2.1.26 A dredge barge in the biological clarifiers improves biosludge recycling and minimizes sludge accumulation in the final polishing pond.

10.2.1.27 An oil skimming system should be installed in the oily stormwater-retention pond. this pond serves as a surge pond for the API separator. This skimming system performs a recovery/recycle function by skimming oil for reprocessing. In addition, the system also reduces the oil loading on the separator and subsequent generation of API separator sludge (hazardous waste) and slop oil emulsion solids (hazardous waste).

10.2.1.28 A vacuum truck should collect catalyst fines which deposit around the process units during loading and unloading operations. This minimizes the amount of solids introduced to the sewer system. This in turn reduces the overall amount of hazardous (oily) wastewater solids generated at the API separator.

10.2.1.29 Rerouting desalter water from API separator to intermediate tankage and then back to separator. This allows for oil skimming at the tank which minimizes emulsion carry-over to the separator, decreasing the generation of slop oil emulsion solids (hazardous waste).

10.2.1.30 Use of a solvent still to reclaim spent paint solvents (hazardous waste).

10.2.1.31 Periodic clean out of oily water sewer system to reduce overall generation of hazardous waste at API separator.

10.2.1.32 Use of covers for all oily water sewer openings in the process area to minimize the amount of solids introduced into the sewer system. This reduces the overall amount of hazardous (oily) wastewater solids generated at the API separator.

11. HAZARDOUS WASTE REDUCTION

The frame work of reduction for control of hazardous waste covers:

- a) Generators;
- b) Transporters;
- c) Treaters;
- d) Stores;
- e) Disposer.

11.1 Generator

Waste generator or handler must determine whether the waste is hazardous. Waste classified as solid hazardous waste must meet two criteria. The first criterion applied is whether the material is a solid waste and the second step is determining whether the solid waste is hazardous. Four characteristics of hazardous waste are:

Ignitability	RCRA	40 CFR	261.21
Corrosivity	RCRA	40 CFR	261.22
Reactivity	RCRA	40 CFR	261.23
Toxicity	RCRA	40 CFR	261.24

Generator owners are responsible for establishing standard operating procedures (SOPs) , that when followed, satisfy regulation . Further more they must ensure that employees follow the (SOPs) as a condition of employment.

These four characteristics are defined in 40 CFR 261 Resource Conservation and Recovery Act, U.S. Regulary Act (RCRA) 1974 and (HSW 4) Hazardous and Solid Waste 1984. Reference can be made to these sources.

For each hazardous waste multi copy form called manifest, which accompanies waste upon leaving the facilities and continues with it to its ultimate disposal.

The tracking system for manifest include name and address of transporter, treater, storer, or disposer; and a description of the wastes, including type, quantities, and official classifications. Manifest should contain certification that the generator is minimizing hazardous waste as much as economically practical and that the chosen method of disposal minimizes risk to human health and the environment.

11.2 Transporter Responsibility

Transport of hazardous waste should take every precautions that spill will not occur and report any spill as soon as possible.

11.3 Treatment, Storage and Disposal Facilities (TSDF)

11.3.1 Treatment

Any method, technique, or process, including neutralization designed to change the physical, chemical, or biological character composition of any hazardous waste so as to neutralize at or render it nonhazardous or less hazardous or to recover it make it safer to transport, store, or dispose of or amenable for recovery, storage, or volume reduction are steps that will reduce the quantity of wastes.

11.3.2 Storage

The holding of hazardous waste for a temporary period and at the expiring time the hazardous waste is treated, disposed of or stored elsewhere are the second steps to reduce the waste.

11.3.3 Disposal

The discharge, deposit, injection, dumping, spilling, leaking, or placing of any solid/waste or hazardous waste into any land or water so that any constituent thereof may enter the environment or be emitted into the air or discharged into any water, including ground-water are factors to be considered for prevention and minimizing of environmental pollution.

The procedures can be divided into two categories: standard of performance and permit requirements. Performance standards shall be per RCRA ACT 40 CFR part 264/265 subparts A

through E. The permit requirement shall be per RCRA ACT 40 CFR 265.

The general provision that apply to all treatment, storage and disposal facilities are as follows:

- a) Waste analysis to ensure accurate information concerning properties of the waste for adequate treatment, storage, or disposal.
- b) Security measure to prevent unauthorized entry with result injury or environmental damage. Inspection to assess the facility and its potential problems.
- c) Training of facility personnel to reduce mistake that could threaten human health, safety, and environment.
- d) Compliance with government standards that include flood plain, earthquake and hydrological considerations.

Land disposal facilities design should be such that to prevent groundwater pollution. New landfills should include double liners and leakage-collection systems. Groundwater quality should be monitored to ensure the protective systems are effective, and they must take corrective action when the systems fail.

12. TREATMENT PRIOR TO ULTIMATE DISPOSAL

12.1 Concentration

Concentrating solids is easily understood when considering that the doubling of solids concentration results in halving the volume for ultimate disposal. Increasing concentration from 1 to 2, or from 2 to 4 percent, is especially important because of the large reduction in volume.

Because of new effluent regulations, wastewater treatment sludges have become the single largest source of sludge. These sludges are difficult to process because they are often gelatinous or oily. Furthermore, the physical properties of wastewater sludge may change frequently because of turnarounds or changes in refinery operations.

Selection of the concentration process depends on the characteristics of the sludge and the ultimate disposal methods available at the specific location.

12.2 Sludge Concentration by Gravity Differential Method

12.2.1 Air floating unit

After removal of the majority of free oil in an API separator, the remaining 50-100 ppm free oil together with colloidal emulsions and suspended solids may be further reduced in a Dissolved or Induced Air Floatation unit (DAF or IAF). These units typically concentrate sludge to 4-5 weight percent.

The basic principle of either DAF or IAF is that air bubbles attach to the suspended oil or solids causing the particles to float to the surface where they can be skimmed. For air floating unit specification refer to API "Manual on Disposal of Refinery Waste".

12.2.2 Chemical flocculation

Chemical flocculation is another pretreatment for removing oil and solids. For more specification refer to API "Manual on Disposal of Refinery Waste".

12.3 Sludge Concentration by Mechanical Dewatering

12.3.1 Centrifugation

Three types of centrifuges are used for processing high solids content sludges—scroll, imperforate basket, and disc. Scroll centrifuges are frequently called solid bowl centrifuges; this is confusing since imperforate basket centrifuges also have a solid bowl.

Oily wastes containing a wide range of solids, oil, and water can be processed by centrifugation. Units have also been designed to process emulsions and oily sludges with high solids content, such as separator and tank bottoms. For three types of centrifuges specification refer to API "Manual on Disposal of Refinery Waste",

12.3.2 Filtration

The various types of mechanical filters which are generally used to concentrate sludges that have been settled or floated by gravity are:

12.3.2.1 Pressure filtration

A pressure filter should consist of metal plates covered by a fabric filtering medium. The covered plates should be hung in a frame equipped with both a fixed and a movable head. The plates should be forced together with a chamber left between the cloth surfaces. Sludge will be pumped through a central opening in the plates to the cloth-lined chamber. Sludge is retained on the fabric and liquid is forced through the fabric to the plate surface where it drains away. At the end of the filtration cycle, the plates are separated, and the sludge cake is discharged from the unit. Feed pressures ranging between 5.5 and 15.5 bar (80 and 225 psi) gage are common.

Pressure filters of the plate and frame type should not be used for filtration of oily sludges or oily slurries because the filter media plugs rapidly. This severely limits the filtration rate. If spent inert solids, such as lime sludge are available, they can be mixed with the waste to provide porosity and improve the ease of removal of the cake from the filter media.

12.3.2.2 Vacuum filtration

The typical filter installation consists of a horizontal compartmented drum, which supports the filter media on its outer surface. The drum is rotated, partially submerged, in a tank containing the waste sludge. As each section of the drum passes through the tank, vacuum pulls the liquid inward and the solids are retained as a thin cake in the filter media covering the outer drum surface. For more detail refer to API "Manual on Disposal of Refinery Waste", 1980.

12.4 Sludge Concentration by Incineration

Incineration is the ultimate in volume reduction. It results in an ash which must be landfilled. Gases are passed out the stack where particulates and acid vapors (CO_2 , SO_2 , and HCl), if present, are removed. Hydrocarbons present in the sludge reduce the amount of auxiliary feed required. The chief disadvantages are the high capital and operating costs.

These costs, per ton of waste incinerated, are especially high for small incinerators and for large incinerators if not used to their full capacity. Therefore in evaluating the need and economics for incineration, three basic steps are required. First, make an accurate estimate of the amount and characteristics of the waste to be incinerated. Second, evaluate alternative disposal methods and types of incinerators. Finally, make an economic and environmental comparison of the alternatives.

12.4.1 Major type of incinerator

For brief description of major type of incinerator and item application refer to API "Manual on Disposal of Refinery Waste", Sections 6.4.1 and 6.4.8.

12.4.2 Incinerator design considerations

Incinerator design requires close cooperation with the incinerator vendor after the characteristics and amount of sludge are known. Specific design considerations depend on the type of incinerator being considered. General factors include:

- 1) The quality of the feed, including variations in composition, production rate, and combustion characteristics. For example, when the feed to a fluid bed incinerator form a low melting eutectic which will bog a fluid bed or will corrosive fumes attack metal rabble arms.
- 2) Control of incineration temperature to ensure complete and safe combustion with minimum maintenance and operating costs. The need for auxiliary fuel, the control of excess air, turbulence, or mixing heat transfer and residence time in the combustion zone must be considered.
- 3) Control of air pollution due to incomplete combustion.

12.4.3 Pyrolysis

Pyrolysis is heating of the waste in the presence of less air than would be required for complete combustion. By doing this some of the hydrocarbon is utilized and some may be partially oxidized.

These materials along with complete products of combustion are burned in an afterburner for heat recovery or, by condensation, some material may be collected as a liquid for subsequent use as a heat or hydrocarbon source. Regeneration of activated carbon is also a pyrolysis process with the limited oxygen being used to prevent complete destruction of the carbon.

12.5 Land Treatment of Hazardous Waste Description

Land treatment is waste treatment and disposal process whereby waste is mixed with or incorporate into the surface soil and degraded, transformed, or immobilized.

Land-treatment technology, site and waste evaluation, design and operation criteria provides the potential environmental effects of land treatment.

12.5.1 Technology

12.5.1.1 Waste characteristic

Bio degradable waste are suitable for land treatment, chemical structure, molecular weight, water solubility and vapor pressure are characteristics that determine the ease of bio degradation.

12.5.1.2 Soil characteristics

Principle soil characteristic affecting land treatment process are pH salinity. Cation-exchange capacity, redox behavior, texture, aeration, moisture holding capacity internal drainage, and soil temperature.

12.5.1.3 Waste degradation

The factors affecting waste degradation may be adjusted in the design and operation of a land treatment facility, as described here:

a) Soil pH

The optimum pH for bacterial growth is near 7. This pH is generally maintained by liming to promote microbial activity and to immobilize heavy metals in the waste.

Soil moisture content should be maintained above a certain minimum usually between 30 and 90%

of water holding capacity of the soil.

Soil temperature should be maintained above 10°C.

Nutrients, additional nitrogen must be supplied when highly carbonaceous waste is applied.

12.5.1.4 Site characteristics

Sites for land treatment should include regional and site geology, hydrology, topography, soil, climate, and land use.

Land treatment facilities should not be located in an aquifer recharge zone or within 60 m of a fault which has had displacement since the Holocene Epoch. Current standards require the treatment zone to be less than 137 cm deep and at least 90 cm above the seasonal water table. Although topography can be modified to some extent by grading, the site should not be so flat as to avoid ponding nor so steep as to cause excessive erosion and run off. The site should not be subject to flooding or washout.

As a treatment medium, the soil should be evaluated in terms of its assimilative capacity (retention and degradation), and the potential for erosion and leaching of hazardous-waste constituents. In general, land treatment facilities should not be established on deep, sandy soil because of the potential for groundwater contamination. Silty soils with crusting problems are undesirable because of the potential for excessive run-off. Generally, soils suitable for land treatment are loam, sandy clay loam (ML, SC), silty clay loam, clay loam (CL), and silty clay (CH). Soil properties that should be evaluated include soil depth, texture, drainage, pH, organic matter, soluble salts, cation-exchange capacity, moistureholding capacity, and microbial counts.

Wind, temperature, and rainfall are three variables of climate that are generally considered in site selection. Careful design and well-planned can overcome most climatic constraints.

Existing and future land use for the site of the land treatment facility should be evaluated in the planning stages. Zoning restrictions, potential effects on environmentally sensitive areas, proximity to existing or planned developments, and effects on the local economy should all be considered.

12.5.2 Advantages and disadvantages of land treatment

The advantages of land treatment are summarized as follows:

- The waste is degraded, transformed, or immobilized; thus, the long-term liability is lower than for other land disposal options.
- The treatment area is continually monitored; thus, remedial action can be taken immediately when there are signs of waste migration from the treatment zone.
- The cost for land treatment is lower than for landfills and incineration.

The disadvantage of land treatment is:

- There is potential for adverse environmental impacts if the facility is not properly designed and managed.

12.5.3 Design consideration

a) Area and Facility Layout

Land treatment generally requires the commitment of a large parcel of land to accommodate the treatment area, buffer zone, roads, waste storage, equipment storage, retention pond, and on-site structures. For this reason, the area available plays a significant role in the layout and in many design and operating features of the facility.

Few salient features are:

TABLE 4 - DESIGN AND OPERATIONAL CONSIDERATIONS

<ul style="list-style-type: none"> · Land requirement · Facility layout · Access road · Equipment selection · Run-on and run-off control · Erosion control · Odor and air-emission control · Waste storage · Land preparation 	<ul style="list-style-type: none"> · pH adjustment and nutrient supply · Frequency and rate of waste application · Application and mixing methods · Contingency plan · Vegetation · Site security and inspection · Site monitoring · Record keeping · Closure and postclosure care
--	---

- b) Equipment.**
- c) Water management.**
- d) Soil erosion.**
- e) Waste application.**
- f) Facility inspection and record keeping.**
- g) Site monitoring.**

12.5.4 Potential environmental impacts

Soil, a natural acceptor of wastes, has been viewed as a physical, chemical, and biological filter that can effectively deactivate, decompose, or assimilate a wide range of waste materials. Factors affecting this assimilative capacity must be considered in order to develop sound systems for land treatment. Without a detailed analysis of land treatment components and a sound design and management plan, adverse environmental effects can result from land treatment practices.

12.5.4.1 Water quality

Operators of land treatment facilities must adequately protect the surface and subsurface waters from contamination with hazardous-waste constituents or by-products from waste degradation. Waste constituents that are not degraded by microorganisms, transformed, or immobilized in soil may leach to the groundwater. Run-off resulting from excess waste application or heavy rains may carry the constituents and contaminated sediments to nearby streams and lakes.

Incorporation of wastes into the surface soil may result in soluble constituents moving downward by leaching. Thus, it would be a race between mobility and degradability of organic waste constituents. Under regulations, the seasonal groundwater table beneath a land treatment facility can be as shallow as 2.40 m below grade, or about 90 cm below the treatment zone. In some cases, an impermeable layer with a leachate-collection system placed a meter or so below the treatment zone can prevent waste constituents or their metabolites from contaminating the groundwater.

Surface-water contamination resulting from improper water or damaged diversion structures and retention ponds is probably a major environmental concern. In a land treatment operation, wastes are concentrated in the soil surface; the concentration of waste constituents in the run-off water may be sufficiently high to have deleterious effects on certain trophic levels in the aquatic ecosystem. Waste constituents may be transported as particulate, dissolved, or bound on eroded soil particles.

12.5.4.2 Air quality

Air quality at a land treatment site can be impaired by odors, dust, volatile substances, and aerosols emitted from waste spreading and incorporating processes. Many industrial hazardous wastes contain heavy metals and organic substances that are highly toxic in particulate or volatile form. The level of volatile compounds present in the air is not necessarily related to the severity of the odor problems. Insufficient data has adverse effects of land treatment practices on air quality. For air monitoring at waste management facilities and for worker protection refer to ASTM D 4844.

12.5.5 Land fill hazardous waste

Land fill contains isolate wastes that are not recoverable to present long-term environmental protection. Disposal to landfill sites, of oily wastes such as sludges obtained from the bottom of separator systems need selection of a suitable location.

Approval of the relevant authorities is necessary before selection of a site for oily waste disposal. Oil may leach from the site into groundwater, if the rock strata are porous, or fissured, it would lead to contamination of the drinking water supplies. In addition, the site has to be selected such that the surface water run-off is either contained or intercepted. The oil must be further stabilized to minimize its mobility. This can be achieved in a number of ways including co-disposal. For co-disposal there should be at least 4 meters of mature domestic refuse between the oily waste level and the base of the landfill. Maturing of the waste takes 3-4 years by which time most of the putrescible and solid organic matter has degraded. In an emergency the oily waste should be dumped on the oldest available refuse.

For high level wastes, e.g., oil or emulsions containing 25% oil and 75% water, the mixing rate should not exceed 5% of the domestic refuse volume. For low level waste, i.e., leached material with an oil content less than 5% by volume, the loading rate should be less than 30% of the underlying domestic waste volume. Ditches or strips for high level wastes should not exceed 300 mm in thickness (preferably 100 mm), and for low level wastes 500 mm is the maximum thickness. 2 m layers of refuse should cover any oily waste layers.

The addition of fly ash or quicklime (CaO) can also be used to render oily sludge inert, and this can be accomplished prior to disposal at a landfill site. Fly ash, the residual ash powder from coal-fired power stations, has a very high surface area and stabilizes the oil by adsorption. The fly ash and sludge may be mixed on site using impellers or screw mixers. The fly ash is added as a polymer-stabilized slurry and the resulting sludge/fly ash mix must be dewatered before dumping. An alternative and less expensive method is to mix the sludge and fly ash at the disposal site using conventional bulldozers and diggers available on site. Quicklime can be used in a similar way to produce a friable, inert material which on compaction can be used as a base infill for low-grade roads. Sludges with oil contents of 5-10% require some 15% quicklime addition, while higher oil contents can be accommodated simply by adding more quicklime. Waste oils can be used for spraying on dirt roads to hold down the dust.

13. DISPOSAL OF WASTE GENERATED IN DRILLING WELL

13.1 Onshore Drilling

Reserve pit (sump) is used to store drilling mud and cuttings to serve as the means for final disposal. The walls of the reserve pit must be high enough to provide 1 to 1.5 m at native topsoils on top of the mud and cuttings after back filling. There are three major methods of disposal.

- 1) Dewatering the pit wastes with subsequent back filling using the pit walls.
- 2) Land farming the wastes into the surrounding soils.
- 3) Transfer by vacuum truck removal to an approved disposal site.

13.1.1 Back filling

Back filling a reserved pit is common method employed. Before the back filling operation begins, it is first necessary to remove the top aqueous layer. After the oil is skimmed, the aqueous layer can be divided by mixing the pit area with organic flocculents such as polyacrylamide, or inorganic such as gypsum. The flocculation should be as complete as possible. When this process is over the aqueous layer should be removed. Sometime it is allowed to evaporate, which can take considerable time. In some cases the wall of the pit dike is cut and the fluid driven out. The analysis should be conducted to ensure that the release of water meets the guidelines of environmental protection and requirements of [IPS-E- SF-880](#).

The aqueous layer can also be removed by vacuum truck and injected:

- 1) Into the well that was drilled (if it is plugged and abandoned);
- 2) Into the drilled well's annulus (if it is completed as a producing well);
- 3) To be transported to a nearby injection well.

After the aqueous layer has been removed, the actual back filling at the reserve pit can be performed.

13.1.2 Land farming

The second major disposal method utilizes landfarming techniques. Landfarming essentially consists of spreading the contents of the reserve pit evenly over the drilling location with subsequent incorporation into the soil using basic soil tilting equipment. Landfarming is specially useful for wells that as producing hydrocarbons.

13.1.3 Vacuum truck removal

In this method both the aqueous and the solid phases of the reserve pit should be pumped to trucks while dirt moving equipment "squeezes" the pit dikes together.

13.2 Offshore Drilling

In offshore drilling the amount of oil discharged is usually restricted. Different disposal techniques are as follows:

13.2.1 Feasible alternates

13.2.1.1 Shunting

The drilling mud and cutting through a pipe extending below the surface of the water (usually near to the sea floor) should be released. Shunting minimizes the physical transport of the wastes and environmental control.

13.2.1.2 Impractical alternates

- a) Transport to an ocean dump site;
- b) Transport to a land disposal area;
- c) Pipelining to another area.

14. DISPOSAL OF PETROCHEMICAL WASTE

14.1 Waste Catalysts

For waste disposal see Clause 10.1.2.

14.2 Alkali and Acid Waste

For waste disposal refer to Clause 10.1.3.

14.3 Oil Sludge

For waste disposal see Clauses 10.1.1 and 10.1.4.

14.4 More Details

More details are available in [IPS-E-PR-735](#).

15. GENERAL SAMPLING CONSIDERATION

15.1 Sampling equipment must be selected that is chemically compatible with the type of waste and type of analyses.

Generally, plastic sampling equipment is not suitable for waste containing or to be analyzed for organic parameter. Stainless steel, glass, and plastic are acceptable for most samples to be analyzed for inorganics. It is up to the user to ensure that the equipment will not contaminate or bias the analyses.

15.2 The sampling equipment must be capable of extracting a sample from the desired location, depth, or point and at the same time provide protection from cross-contamination during sampling. For instance, one very common problem is extracting a sludge sample from beneath a top layer of wastewater or sludge without contaminating the sample with the overlying wastewater or sludge. This situation, as well as many others, requires special equipment. The collector is therefore faced in many instances with having to fabricate the needed equipment.

15.3 Recommended sampling procedures are for collection of samples from the edge of ponds or lagoons or from pier or catwalks. Sampling from boats is not recommended and should be attempted only if the collector knows the waste poses no real health problem and every possible safety measure has been taken.

15.4 Tanks and drums containing unknown substances also pose potential health risks for the collector due to the possibility of fire, explosion, or the release of deadly gases upon opening. In these situations only spark-proof, remote opening devices be used and only fully trained and experienced personnel attempt to do this.

15.5 Samples which have not been properly mixed or were mixed in such a way that constituents such as volatile organic compounds are destroyed or driven off are not truly representative. Some of the most difficult types of samples to composite are cohesive finetextured solids and sludges. Lime-neutralized metal finishing wastes are an example of these wastes. Because of the sticky cohesive nature of these wastes, mixing is very difficult in the field. It may be best to have the laboratory mix the sample. Depending on the type of analyses required, it may be possible to slurry and mix the sample by the addition of water without affecting the analyses. The laboratory personnel should be consulted before attempting this. If the composite has not been appropriately mixed prior to shipment, this should be clearly indicated on the sample.

15.6 The volume of sample needed depends on the type of analyses needed and the testing equipment and procedure to be followed. There are two rules-of-thumb which can be applied.

15.6.1 If low chemical concentrations of a parameter to be tested are expected, take a large volume of sample.

15.6.2 If high chemical concentrations of a parameter to be tested are expected, smaller volumes will suffice.

15.7 When possible, it is recommended that sampling proceed from the least contaminated to the most contaminated areas to reduce problem of cross contamination.

15.8 General Planning of Waste Sampling

The analysis and testing of solid waste requires collection of adequately sized, representative samples. Wastes are found in various locations and physical states.

Each sampling routine must be tailored to fit the waste and situation. Wastes often occur as nonhomogeneous mixtures in stratified layers or as poorly mixed to form a mass. For example, wastes are commonly stored or disposed of in surface impoundments with stratified or layered sludges covered by ponded wastewater. In these situations, the collector may be faced with

sampling the wastewater, the sludge, and some depth of soil beneath the sludges. Collecting representative samples in these situations requires a carefully assessed, well-planned, and well-executed sampling routine.

15.8.1 Significance and use

The procedures covered in this guide are general and provide the user with information helpful for writing sampling plans, safety plans, labeling and shipping procedures, chain-of-custody procedures, general sampling procedures, general cleaning procedures, and general preservation procedures.

15.8.2 Sampling plans

a) A sampling plan is a scheme or design to locate sampling points so that suitable representative samples descriptive of the waste body can be obtained. Development of sampling plans requires the following:

- Review of background information about the waste and site.
- Knowledge of the waste location and situation.
- Decisions as to the types of samples needed.
- Decisions as to the sampling design required.
- Background data on the waste is extremely helpful in preassessment of the waste's composition, hazards, and extent.

Note:

The background information is needed to determine necessary safety equipment, safety procedures, sampling equipment and sampling design, and procedures to be used. For more details see ASTM D4687.

- Waste location and site conditions greatly influence a sampling plan. The most common waste locations may include lagoons, landfills, pipes, point discharges, piles, drums, bins, tanks, and trucks. The site conditions include the physical condition of the waste; it is a solid, liquid, or gas, and describes the conditions it was disposed.

15.8.3 Consideration

15.8.3.1 Based on these considerations, the collector must be able to sample.

15.8.3.2 The types of samples that may be collected are either composite or single. The sample collector must sort the samples and provide representative samples.

15.8.3.3 A composite sample, is a well-mixed collection of sub-samples of the same waste taken from different points. A composite sample can be used in determining an average measure of a parameter and are taken when differences in the waste exist.

15.8.3.4 A single sample is a well-mixed sample taken from a single point. It is used to measure a particular parameter or parameter set at a given point or within a unique homogeneous layer or throughout the strata at one or several locations.

15.8.3.5 Sampling plans or schemes should be prepared well in advance of sampling. The most common sampling schemes involve the selection of sampling points, coordinate system, or a grid system.

15.8.4 Coordinate sampling system

This system uses a one or two coordinate system and involves collecting samples at random points from the origin of the coordinates. Random numbers can be generated using random number tables available in most statistic texts. The origin of the coordinate system is normally placed at some corner of the site and marked off in steps, centimeter, meter, etc., for sampling landfills, waste piles, and lagoons. For storage areas containing barrels, the numbers of barrels from the origin are often used as intervals along the coordinate. For sampling from a flowing stream the origin may be taken as time-zero (start), and samples are collected at random time intervals over the period of interest.

15.8.5 Grid system

This system also involves taking samples at regular intervals, grid points, along an imaginary grid system laid out over the site. The number of sampling points will vary with the size of the grid. Such sampling schemes are used when a statistically sound sampling program is required. They should be used only when the waste body is known to be homogeneous, or when the strata have been defined. If the waste is stratified, a separate grid system may be required for each stratum.

15.9 Sampling Equipment

15.9.1 Composite liquid waste samples (coliwasa)

Coliwasa is a device employed to sample free-flowing liquids and slurries contained in drums, shallow tank, pits and similar container.

The coliwasa consists of a glass, plastic, or metal tube and should be equipped with an end closure that can be opened and closed while the tube is submerged in the material to be sampled (Fig. 1).

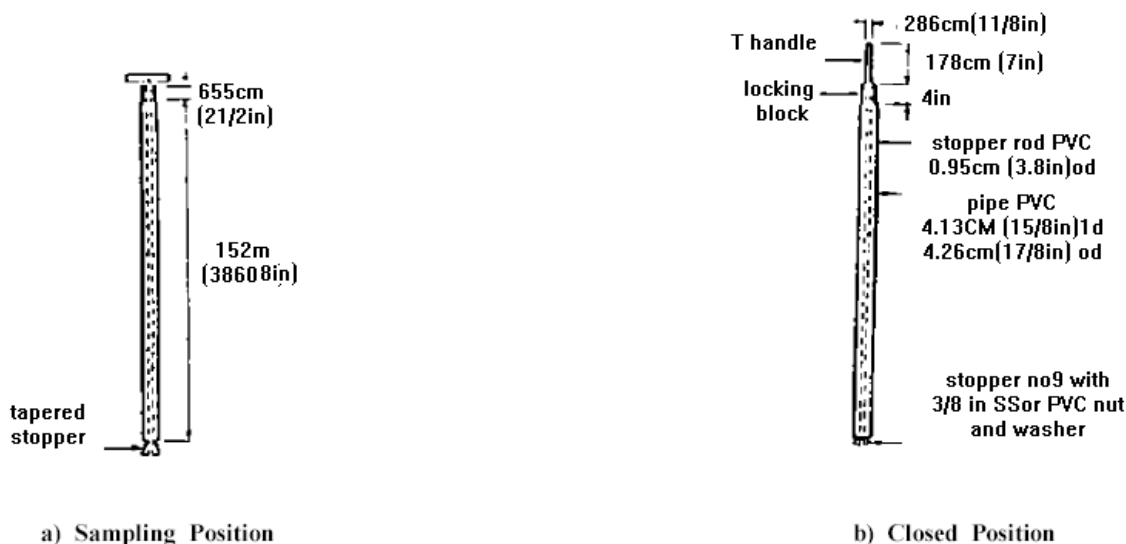

COMPOSITE LIQUID-WASTE SAMPLER (COLIWASA)

Fig. 1

15.9.2 Weighted bottle

This sampler (Fig. 2) consists of a glass or plastic bottle, sinker, stopper, and a line that is used to lower, raise, and open the bottle. The weighted bottle samples liquids and free-flowing slurries. A weighted bottle with lime is built to the specifications in ASTM Methods D 4057 and E300.

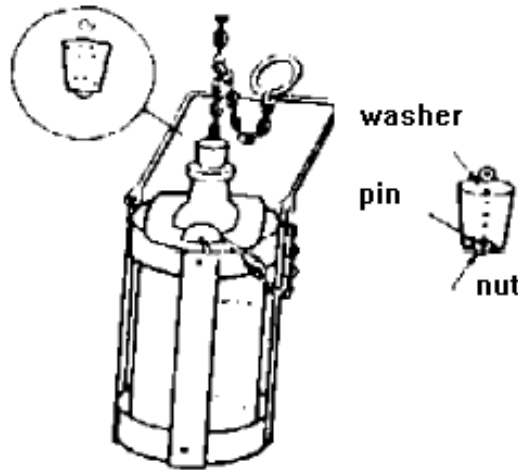

WEIGHTED-BOTTLE SAMPLER
Fig. 2

15.9.3 Dipper

The dipper (Fig. 3) consists of a glass or plastic beaker clamped to the end of a two-or three-piece telescoping aluminum or fiberglass pole that serves as the handle. A dipper samples liquids and free-flowing slurries. Dippers are not available commercially and must be fabricated.

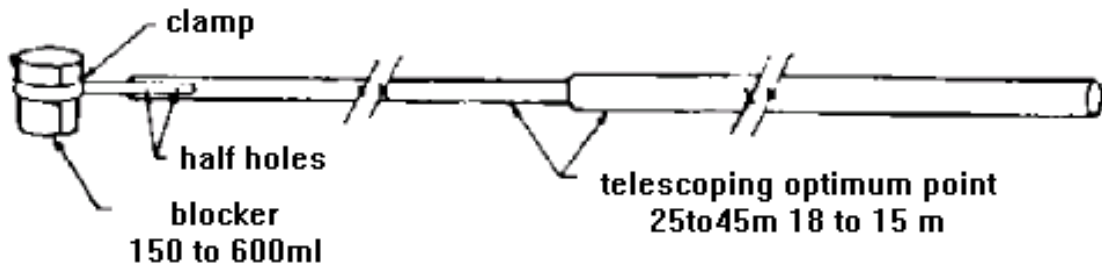

DIPPER
Fig. 3

15.9.4 Thief

A thief (Fig. 4) consists of two slotted concentric tubes usually made of stainless steel or brass. The outer tube has a conical pointed tip that permits the sampler to penetrate the material being sampled. The inner tube is rotated to open and close the sampler. A thief is used to sample dry granules or powdered wastes whose particle diameter is less than one-third the width of the slots. A thief is available at laboratory supply stores.

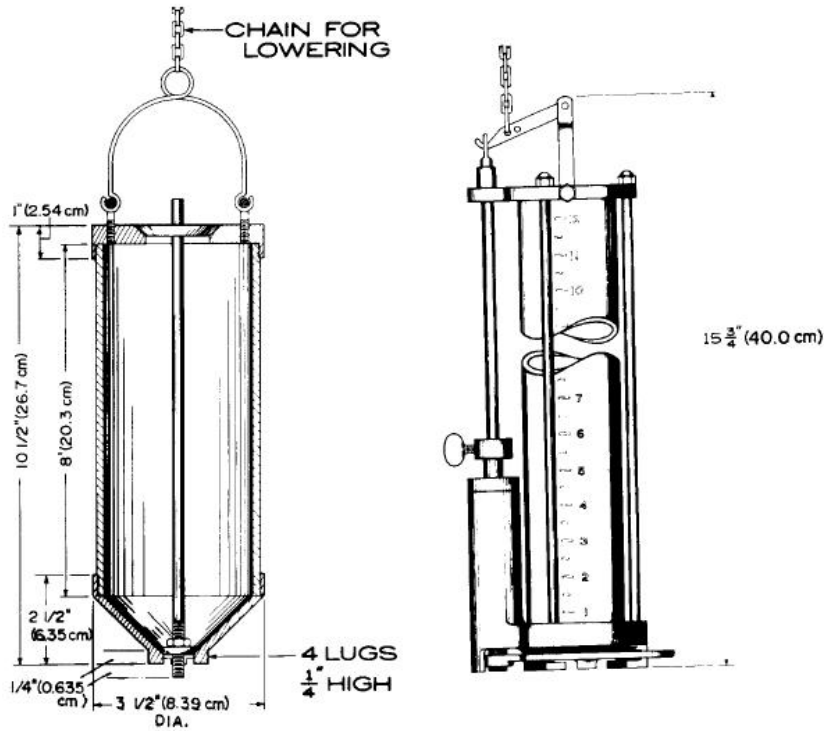

(a) Bomb-Type Sampling Thief

(b) Core Thief, Tap-Type

SAMPLING THIEFS

Fig. 4

15.9.5 Trier

A trier (Fig. 5) consists of a tube cut in half lengthwise with a sharpened tip that allows the sampler to cut into sticky solids and to loosen soil. A trier samples moist or sticky solids with a particle diameter less than one-half the diameter of the trier. Triers 61 to 100 cm long and 1.27 to 2.54 cm in diameter are available at laboratory supply stores. A large trier can be fabricated.

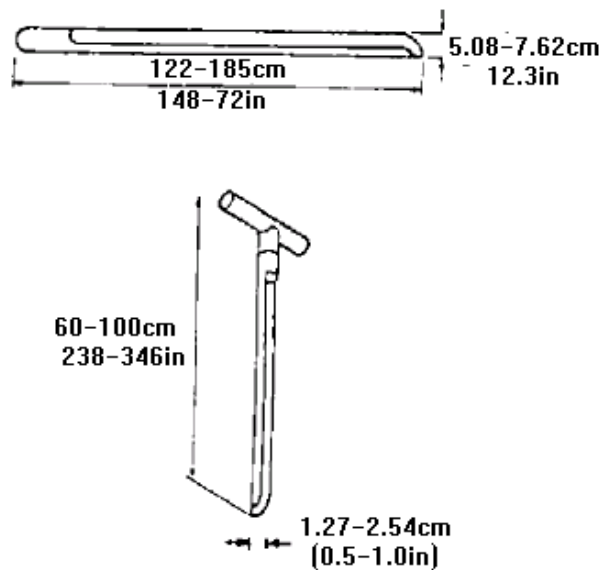

TRIER SAMPLER

Fig. 5

Table 5 provides examples of sampling equipment used in sampling waste in various containers or impoundment:

TABLE 5 - EXAMPLES OF SAMPLING EQUIPMENT FOR PARTICULAR WASTE TYPES

Waste type	WASTE LOCATION OR CONTAINER							
	Drum	Sacks and bags	Openbed truck	Choppedbed truck	Storage tanks or bins	Waste piles	Ponds, lagoons, & pits	Conveyor belt
Free-flowing liquids and slurries	Colivasa	NA	NA	Colivasa	Weighted bottle	NA	Dipper	NA
Sludges	Trier	NA	Trier	Trier	Prier	*	*	
Most powders or granules	Trier	Trier	Trier	Trier	Prier	Trier	Trier	Shovel
Dry powders or granules	Thief	Thief	Thief	Thief	*	Thief	Thief	Shovel
Sand or pecked powders and granules	Auger	Auger	Auger	Auger	Thief	Thief	*	Dipper
Large-grained solids	Large trier	Large trier	Large trier	Large trier	Large trier	Large trier	Large trier	Trier

16. AIR MONITORING OF WASTE FOR EMPLOYEES PROTECTION

16.1 General

This section apply to routine operations at an active treatment, storage, or disposal site or the extra ordinary conditions that can be encountered in opening and cleaning up a remedial action site.

The user must predict all the difficulties that could develop at waste facility due to hazardous airborne transmissions. Although air contaminant measurements obtained may indicate acceptable tolerable levels of toxic agents are present, care must still be exercised before concluding that all atmospheric contaminants at the site are under control.

16.2 Significance and Use

16.2.1 The techniques of air monitoring are many and varied. This guide is intended to describe the standard approaches that are used in designing and air monitoring program to protect waste management site workers.

16.2.2 When entering a remedial action site to initiate an investigation or a cleanup operation, operating personnel may be faced with the extreme hazards of fire, explosion, and acute or chronic health hazards. A thorough safety and health program, including a site-specific safety and health plan, must be in place to direct worker activity. Details for such plans can be found in the OSHA Interim Final Rule for Hazardous Waste Operations and Emergency Response. Air monitoring is an integral part of such a program Clause 12.6.4 describes sampling procedures which can be used to evaluate the airborne hazard potential so as to gain and maintain control over the situation at the site.

16.2.3 Upon obtaining readings at the site, a decision must be made as to whether conditions are under control or not. That decision will depend on the nature of the contaminants (toxicity, reactivity, volatility, etc.), the extent (area affected, number of workers, etc.) of the problem and the level of worker protection available. Since all such parameters will be site specific, the necessary decision-making is beyond the range of this Standard.

16.2.4 This Section does not include monitoring sites containing radioactive materials, nor does it cover general safety aspects, such as access to emergency equipment or medical support of emergency needs. These items should be covered in a safety and health plan.

16.3 Establishing a Test Protocol

16.3.1 Various combinations of equipment and sampling techniques are used in work place air monitoring. The best monitoring program is one that combines accuracy with timely response in a cost effective manner.

16.3.2 The particular test protocol which is selected for an industrial hygiene study depends on the nature of the contaminants and the end purpose of the monitoring effort (that is, routine monitoring, searching for worst case exposure, looking for contaminant leaks in a process).

16.4 Selecting Specific Methods

16.4.1 The choice of sampling method is most often tied in with the analytical method. There may be no difference in the analytical work whether it is for a 15-min. ceiling sample or a 7-h full day sample. If the analytical method has poor sensitivity, however, it may be necessary to increase the pump flow rate for the short duration sample to make certain that sufficient sample is collected. Such fine adjustments must be worked out between the sampling personnel and the laboratory personnel.

16.4.2 A number of sources of information are available to describe general methodology. Recommended Practice ASTM D1605 lists some of the classic methods that have been used when sampling for gases or vapors. The American Conference of Governmental Industrial Hygienists offers a publication, that provides a review of newer equipment and methodology. The final combination of equipment and procedures is predicted on the precision, accuracy, and sensitivity needed to support the test protocol.

16.4.3 Once the goals and protocol for the sampling program have been set, specific sampling/analytical method must be selected. Within the Annual Book of ASTM Standards, Volume 11.05 is dedicated to atmospheric analysis and to occupational health and safety issues. Some applicable methods from that reference are listed in Annex A1. Other sources of health and safety support include the NIOSH Manual of Analytical Methods and the OSHA Analytical Methods Manual. The specific equipment and sampling media for a particular set of airborne contaminants are selected from sources such as these.

17. PROCEDURES

17.1 Operating Site

17.1.1 The procedures described in this section apply to air monitoring activities at an operational waste treatment storage, or disposal site. At an operating site, controls (work practices, engineering controls, and personal protective equipment) would be in place to minimize the exposure of workers to hazardous conditions. These are defined in the health and safety plan.

17.1.2 Knowledge of materials

Knowledge of the materials arriving at or present at an operating site is critical to the design of a sampling plan. If hazardous wastes are arriving be sure that they are listed on the manifest. The results of waste sample analyses will also help to identify contaminants of greatest concern in an incoming shipment. It is also likely that specific users of the disposal site will tend to be consistent in the types of wastes they send to the site based on the generating process and history of shipment. For example, paint manufacturers will most likely send mixtures of solvents, resins, and pigments, whereas plating firms will generally send alkaline sludge of heavy metal waste; and so on. Deviation from established patterns, however, is possible and should not be discounted in sampling plan design.

17.1.3 Worker sampling

17.1.3.1 Of all the different techniques for workplace air monitoring, personal sampling of the worker's breathing zone is paramount. While some workers may be quite sedentary in an operations trailer at a control panel, others may be out covering all areas of the work site. For this reason, the assessment must be capable of following the activity of the worker.

17.1.3.2 The first order of personal monitoring is long duration Time Weighted Average (TWA) sampling. For an 8 h work shift, be sure that TWA samples are at a minimum of 7 h duration either as a single sample or a series of two or more samples. For any other work hour situation, the procedure is to sample for the duration of the shift less than 1 h.

For workers handling organic wastes (for example, vapor degreaser solvent waste) the program would call for charcoal tube sampling with analysis for one or two of the chlorinated solvents most likely to be present in the waste. Such TWA monitoring, as well as the following information, would be repeated periodically to ensure that worker exposure is not increasing.

17.1.3.3 Another form of personal monitoring that would be carried out is for peak exposures. For example, 15 min. ceiling samples might be taken while a set of containers was being opened to inspect or remove the contents. The same type of sampling might be done while pumping the contents of a truck into a holding tank. At these times, personal protective equipment (for example, respiratory protection) is often used to minimize worker exposure to vapors. Ceiling samples will help ensure that workers are using respirators having a high enough protection factor.

17.1.3.4 Ceiling samples might be the only form of monitoring for certain toxic agents. If waste acid pickling solution were to come in from a steel mill for neutralization, it might be appropriate to sample for hydrogen chloride. In that instance, only 15 min. samples would be of interest, because that is how exposure to HCl is controlled by health/- regulatory agencies.

17.1.3.5 New equipment has come into use to cover both TWA and peak sampling. Some personal dosimeters, worn by the employees, give an overall average exposure and also record the instantaneous exposures of the worker during the day.

These units, which are read out on a portable computer, are generally good for only one particular contaminant, though all the different types are read using the same computer. These might be very useful in monitoring a heavy equipment operator for carbon monoxide or a waste treatment plant attendant for sulfur dioxide.

17.1.3.6 Another concept to be considered in both the monitoring and safety and health plans is the additive effect of certain substances. Paragraph 7.1.3.2 of ASTM D 4844 presented the concept of screening for only one or two solvents. When this is done, the eventual comparison with permissible exposure limits must be done using a safety factor. This safety factor is intended to take account of the possible effects of other similar compounds which are likely to be present, but are not measured routinely.

17.1.4 Area monitoring

17.1.4.1 A good complement to personal monitoring is fixed location area monitoring. This can be done with either sample collecting-type equipment, direct reading instruments, or specialized fixed-parameter monitors such as those described in 7.1.3.5 of ASTM D 4844. Area monitoring offers the advantage of potentially providing an early warning.

17.1.4.2 A combustible vapor meter in a solvent storage area can give warning before an employee must walk in to find a leak.

17.1.4.3 A carbon monoxide monitoring system around a pyrolyzer or incinerator can warn both the operator in the control room and workers in the loading area of a system upset.

17.1.4.4 An oxygen meter permanently mounted in a below ground pit can warn an employee of an oxygen deficient atmosphere before he enters the confined space.

17.1.4.5 Direct reading colorimetric tubes, offer a convenient means for obtaining a quick reading.

Besides their suitability for qualitative checks, they also provide reasonable quantitative estimates. For more detail please refer to ASTM D 4844.

18. HAZARDS

18.1 Proper safety precautions must always be observed when sampling wastes. Persons collecting samples must be aware that the waste can be a strong sensitizer and can be corrosive, flammable, explosive, toxic, and capable of releasing extremely poisonous gases. The background information obtained about the waste should be helpful in deciding the extent of safety precautions to be observed and in choosing protective equipment to be used.

18.2 Personnel should wear protective equipment when response activities involve known or suspected atmospheric contamination; when vapors, gases, or airborne particulates may be generated; or when direct contact with skinaffecting substances may occur. Respirators can protect lungs, gastrointestinal tract, and eyes against air toxicants. Chemical-resistant clothing can protect the skin from contact with skin-destructive and-absorbable chemicals. Good personal hygiene limits or prevents ingestion of material.

18.2.1 Equipment to protect the body against contact with known or anticipated chemical hazards has been categorized in [IPS-M-SF-325](#) "Personnel Safety and Fire Fighters Protective Equipment".

19. QUALITY ASSURANCE CONSIDERATION

19.1 Quality assurance for solid waste sampling should include adherence to the sampling plan and safety plan and in some cases, the use of quality control samples.

19.2 Four types of quality control samples relate to the quality assurance of field sampling:

- 1) field blanks,
- 2) split samples,
- 3) field rinsates, and
- 4) field spikes.

The selection of the types of quality control samples to be used should be made prior to the sampling event and included in the sampling plan. The nature of the sampling, the intended uses of the data, and the material being sampled all impact upon the selection of quality control samples to be used in an event.